

Carbon Capture and Storage

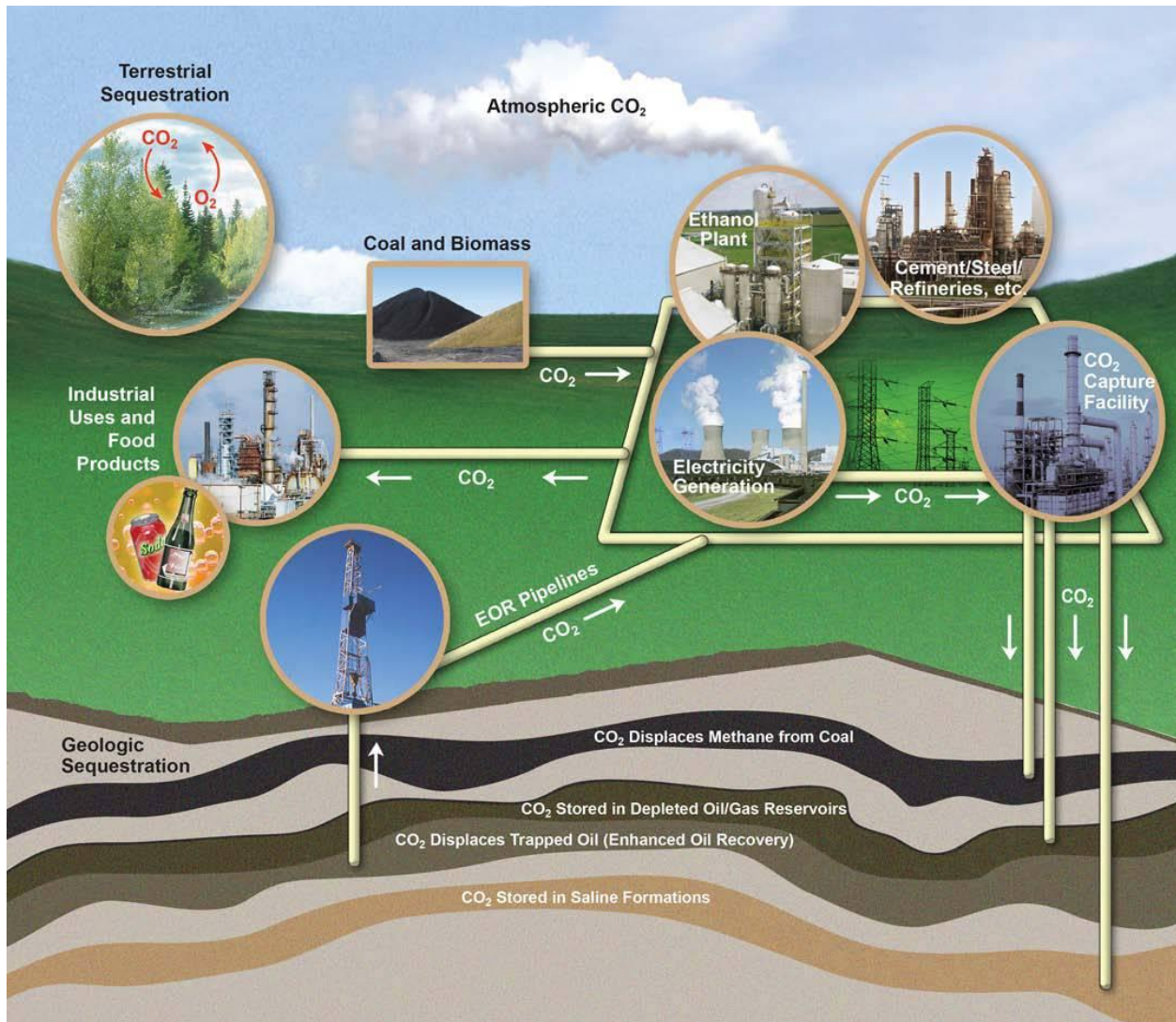

Figure 1: Anthropogenic Carbon Cycle [1.1]

Kanin Bodipat

Dhiraj Dhiraj

Evan Frye

Louyi Hua

Toby McCabe

Executive Summary

This report examines the implementation of retrofitting and sequestration technologies on a 572MW coal plant in Shawville, PA for Carbon Capture and Storage (CCS) and Enhanced Oil Recovery (EOR) to make the project viable while reducing associated costs. This evaluation covers current government policies, capture technologies, transportation, sequestration within enhanced oil recovery, and monitoring environmental health and safety.

To mitigate the effects of climate change, carbon reduction strategies have been proposed to reduce anthropogenic emissions of green house gases due to fossil fuel use. Geologic sequestration of carbon dioxide (CO₂) may serve as a short-term solution to this long-term issue of increasing atmospheric CO₂ concentrations until alternative forms of energy beyond fossil fuels are proven economically feasible. The driver towards developing and implementing carbon sequestration strategies lies in new legislation in global and domestic policies. Carbon capture and storage (CCS) is poised as a potential mechanism to remove CO₂ before it is emitted into the atmosphere and transported through pipeline networks to a storage site. These transport networks are expensive and complex, and regional partnerships have been established to develop best management strategies for dealing with the long-term storage of CO₂. Geologic sequestration may represent the greatest strategy for the long-term storage of carbon dioxide because immense volumes of CO₂ can be stored in various underground formations. The costs associated with these technologies are extremely high, but there is an opportunity to reduce these costs through enhanced oil recovery via the underground injection of carbon dioxide into poorly producing oil and natural gas reservoirs. Carbon capture and storage strategies will only be effective in the mitigation of carbon dioxide emissions if they are cost-effective and pose little risk to environmental and human health. Various monitoring strategies have been proposed to assess the short and long term effectiveness of these projects and reduce associated risks.

Current policies and legislation highlight an increasing effort by both the federal and state governments to establish both an effective carbon cap-and-trade program and laws that provide bonus incentives in the form of carbon credits. Support from the government and related agencies are absolutely essential in order to make CCS projects economically feasible. Beyond understanding current policies, an analysis was performed for the most developed commercial scale carbon capture technology, MEA absorption, and compared with a new and promising technology, CAP. Through reviewed literature and software analysis, two processes were applied to the Shawville plant and it was determined that MEA absorption is the better, currently available technology on the basis of economics. The process shows an energy penalty of 11.7%, which brings the total thermal efficiency of the power plant down to 20.5%, and an avoided cost of \$57.06 per ton of CO₂ captured. This study successfully characterized the carbon dioxide capture potential at the Shawville plant and further investigations of transportation and storage technologies revealed where this project can store its abated CO₂ emissions. Hydraulic parameters studied in Midwest Regional Carbon Storage Partnership region (MRCSP) show the Rose Run formation is a suitable storage site. In order to determine the best available injection site for this CCS project, the Ogden and CMU correlation economic models were compared. The annualized total capital costs of these two transportation scenarios yielded significantly different results. Pipeline length is the key parameter for associated transportation costs because of variations in construction and infrastructure

capital. Transportation costs can be minimized if CCS technologies are utilized within an enhanced oil recovery paradigm. Our ultimate storage site will be set up after implementation of geologic carbon sequestration within EOR. The potential of CO₂-EOR is globally significant and the United States is poised to benefit from its domestic application. CCS can also be done within EOR to mitigate the greenhouse gas effect of CO₂. This CCS project will only prove successful if we can reduce the associated implementation costs and ensure that geologic sequestration is done in a safe and sustainable manner. Ongoing site monitoring will be essential to understand the maturation of the injected reservoir and predict any sources of CO₂ leakage which may undermine the project and pose hazardous to environmental and human health. Carbon capture and storage can be made economically viable when carried out within EOR and through governmental support to subsidize the associated costs. After an evaluation of the available CCS technologies for retrofitting the Shawville power plant, this study concludes that carbon capture and storage is only economically feasible beyond the project's first ten years if project costs are further subsidized through additional government bonus incentives or profits from EOR by \$46.87 per ton of CO₂ captured.

Table of Contents

Executive Summary.....	ii
Chapter 1: Introduction	1
1.1 Problem Statement.....	1
1.2 Overview	1
Chapter 2: Policies and Regulations.....	1
2.1 Introduction [2.1] [2.2].....	1
2.2 The Beginning of Regulations ^[2.13]	2
2.3 Stake Holders ^{[2.1] [2.2] [2.3] [2.4] [2.9]}	2
2.4 The Cap-and-Trade Program ^{[2.5] [2.6] [2.7] [2.10]}	4
2.5 Worries on Geologic Sequestration ^{[2.1] [2.2]}	6
2.6 Climate Change Action Plan ^{[2.3] [2.11]}	7
2.7 Policy-related Commercial Terms ^{[2.2] [2.4] [2.8] [2.12]}	10
2.8 The future of CCS ^[2.9]	11
Chapter 3: Retrofitting of an Existing Power Plant	12
3.1 Shawville Power Plant Specifications: ^[3.1]	12
3.2 Carbon capture technologies: ^{[3.2], [3.3]}	13
3.2.1 Post-combustion capture.....	13
3.2.1.1 Amine-based absorbents	13
3.2.1.2 Aqueous ammonia absorption.....	14
3.2.1.3 Membranes	15
3.2.1.4 Solid adsorbents.....	16
3.2.2 Oxy-combustion	17
3.3 Capture Technology Selection	17
3.3.1 Monoethanolamine Analysis	17
3.3.2 Chilled Ammonia Process Analysis.....	18
3.3.3 Summary and Comparison of Selected Technologies.....	19
3.3.4 Future Capture Work	20
Chapter 4: Transportation and Storage with cost estimation	21
4.1 Introduction	21
4.2 Geological CO ₂ Sequestration Opportunities in the MRCSP	21
4.2.1 A Snapshot of the MRCSP	21

4.2.2 General geologic storage potential in MRCSP	23
4.3 Carbon Storage Site Selection---Rose Run	25
4.3.1 Deep Hydrostratigraphic Unit	25
4.3.2 Hydraulic Parameters.....	26
4.4 Reservoir Capacity Estimates	27
4.5 Transportation	29
4.5.1 Scenarios for CO ₂ pipeline.....	29
4.5.2 Special design consideration for CO ₂ transmission system	30
4.5.2 Pipeline Right of Way Consideration (ROW).....	31
4.6 CO ₂ Transportation Cost.....	31
4.6.1 Basic Assumption	31
4.6.2 Calculations of Compressors & Pump Power Requirements.....	32
4.6.3 Capital, O&M, and Levelized Costs of CO ₂ Compression and Pumping.....	33
4.6.4 Determine the diameter of pipeline	35
4.6.5 Capital, O&M, Levelized Costs for CO ₂ Transportation.....	36
4.7 Future work.....	38
Chapter 5: Sequestration of CO ₂	39
5.1 Introduction	39
5.2 Geological Description of Rose Run Formation	40
5.3 Suitability of Rose Run Formation For Reliable Carbon Storage in Oil/Gas Reservoirs Within EOR.	41
5.4 Physical Properties of CO ₂	41
5.5 CO ₂ Migration Behavior with the Pore Fluid	42
5.6 Trapping Mechanism	42
5.6.1 Hydrodynamic trapping	42
5.6.2 CO ₂ residual trapping	42
5.6.3 Solubility trapping.....	43
5.6.4 Mineral trapping	43
5.7 Forced Mineral Trapping.....	44
5.8 Technical Aspects and Challenges in Sequestration	45
5.9 Modeling Of Sequestration of CO ₂ in Rose Run.....	46
5.10 Economic Analysis for Sequestration.....	48
Chapter 6: CO ₂ Utilization for Enhanced Oil Recovery.....	49

6.1 Introduction	49
6.2 Enhanced Oil Recovery Using CO ₂	49
6.3 Scope & Potential of CO ₂ -EOR in United States.....	49
6.4 Technical Aspects of CO ₂ -EOR.....	51
6.5 Reservoir Fluid & Formation Properties	51
6.6 Process Description.....	52
6.6.1 CO ₂ injection & miscible displacement of oil:.....	52
6.6.2 Production & Wag (water alternating gas).....	53
6.6.3 Recycling	54
6.6.4 Sequestration	54
6.7 Modeling of CO ₂ -EOR.....	55
6.8 Results.....	56
6.9 Economic Analysis of Sequestration With in EOR.....	60
Chapter 7: Monitoring of Underground CO ₂ Reservoirs.....	61
7.1 Introduction	61
7.2 Statement of Purpose	62
7.3 Reservoir Assessment	62
7.3.1 Pre-injection Assessment.....	62
7.3.2 Injection Monitoring	63
7.4 Monitoring Techniques.....	64
7.4.1 Optical Fibers	64
7.4.2 Gas Detection.....	65
7.4.3 Geochemical Monitoring	65
7.4.4 Bio-monitoring	67
7.5 Costs associated with monitoring.....	68
7.6 Conclusions	69
Chapter 8: Project Conclusions and Recommendations for Future Work.....	70
8.1 Cost Analysis	70
8.2 Conclusions and Recommendations	72
Appendix A – Capital cost for CO ₂ Pipeline Transportation.....	73
A1. Parameters.....	73
A2. Calculation of Compressors/Pumps Power Requirements.....	74

A3. Capital, O&M, and Levelized Costs of CO ₂ Compression/Pumping.....	76
A.4 Determine the Diameter of Pipeline.....	78
A.5 Pipeline Transportation cost.....	79
APPENDIX B – EOR Calculations.....	80
B.1 Various costs involved in EOR process.....	80
B.2 Calculation of Original Oil in Place (OOIP) In Coalfax Field.....	81
Appendix C – CCS Monitoring.....	82
Works Cited.....	85

List of Figures

Figure 1: Anthropogenic Carbon Cycle [1.1].....	i
Figure 2: Massachusetts v. Environmental Protection Agency Supreme Court case.....	2
Figure 3: Logos and diagrams of CCS stake holders.....	3
Figure 4: Cap-and-Trade Cycle.....	4
Figure 5: Coal-fired Power Plant in Pennsylvania.....	6
Figure 6: U.S. Map of states with climate change action plan or initiative.....	7
Figure 7: Pennsylvania State Capitol building.....	7
Figure 8: Governor Edward G. Rendell.....	8
Figure 9: Cover page of the Climate Change Action Plan.....	9
Figure 10: CO ₂ Capture Project Brochure.....	10
Figure 11: Computer-Generated cross section of a sequestration site (Energy Tribune).....	12
Figure 12: Highest reported CO ₂ capacities of all solid adsorbent classes at different temperatures.....	16
Figure 13: MEA Capture Cost and Energy Penalty Analysis.....	18
Figure 14: CAP flow diagram [SuperPro Designer®].....	19
Figure 15: Makeup of the Seven DOE Regional Partnerships (c. September 2005).....	22
Figure 16: MRSCP Oil and Gas Fields as targets for carbon sequestration.....	24
Figure 17: Saint Peter and Rose Run formations.....	25
Figure 18: Major Power Plant and the Rose Run Formation.....	27
Figure 19: Estimated Injection Capacities underlying Shawville for a 25-mile radius injection site.....	28
Figure 20: Visualizing the Levelized Capital, O&M and Power cost [\$/ton CO ₂].....	34
Figure 21: Annualized costs as a function of Pipeline Length.....	35
Figure 22: The boundaries, inputs, and output of the pipeline model.....	36
Figure 23: Transportation Cost as a Function of CO ₂ Pipeline Length.....	37
Figure 24: Levelize Transportation Cost as a Function of CO ₂ Pipeline Length.....	37
Figure 25: Total Annual Cost as a Function of CO ₂ Pipeline Length.....	38
Figure 26: Measured section of core through part of the Rose Run Sandstone.....	40
Figure 27: Phase behavior of CO ₂	41

Figure 28: Differences between various CO ₂ Trapping mechanisms in geological media: (a) operating timeframe, and (b) contribution to storage security	44
Figure 29: Mineral Trapping behavior	45
Figure 30: 3-D representation of the field	47
Figure 31: Cumulative and rate of CO ₂ injection	48
Figure 32: Potential Target for CO ₂ EOR	50
Figure 33: US Oil Production from CO ₂ EOR Projects by Year.....	50
Figure 34: Sequestration of CO ₂ within EOR.....	52
Figure 35: Binary mixture behavior of CO ₂ and Oil at 120F.....	53
Figure 36: WAG (water alternating mechanism)	54
Figure 37: 3-D representation of the field	55
Figure 38: Cumulative injection of CO ₂ during 10 year EOR period.....	56
Figure 39: profile of CO ₂ injection over 30 years	57
Figure 40: Cumulative oil production from well 1	58
Figure 41: Profile of CO ₂ production.....	58
Figure 42: Profile of H ₂ O production.....	59
Figure 43: Pressure profile after 10 years of operation.....	59
Figure 44: Pressure profile after 30 years of operation.....	60
Figure 47: Abandoned oil and natural gas well in Pennsylvania [7.43]	82
Figure 7.45: Hypothetical injection rates (Mt CO ₂ /year) in Rose Run Formation. [7.35]	82
Figure 46: Hypothetical injection rates (Mt CO ₂ /year) in Rose Run Formation. [7.35]	82
Figure 48: Hypothetical CO ₂ pipelines to Rose Run formation. [7.36].....	83
Figure 49: Pennsylvania Department of Environmental Protection Water Monitoring Network [7.44] ...	83
Figure 50: Major aquifers in Pennsylvania.....	83
Figure 51: kill at Mammoth Mountain from CO ₂ fumaroles [7.45].	84
Figure 52: Land cover of Pennsylvania [7.46].	84

List of Tables

Table 1: GHG emission reduction targets	5
Table 2: Pros and Cons for Legislation	5
Table 3: PC Plant Energy Performance with and without CO ₂ Capture Comparison [3.4]	15
Table 4: Flue Gas Composition (w/out capture)	19
Table 5: Shawville Plant Performance with and without CO ₂ Capture	20
Table 6: Hydraulic Parameters of Rose Run.....	26
Table 7: Case study input parameters and distributions for the transport models	32
Table 8: Calculated power requirements for two storage site	33
Table 9: Cost of Capital, O&M, and Levelized Costs of CO ₂ Compression and Pumping.....	33
Table 10: Conclusion of Transportation Cost.....	38
Table 11: Ground rock properties of formation	46
Table 12: Rose Run assumed rock properties.....	46

Table 13: Cost of reworking wells	48
Table 14: Rose Run Reservoir Fluid and Formation Properties	51
Table 15: Economic analysis of EOR.....	61
Table 16: Cost associated with geologic sequestration project near Shawville, PA.....	68
Table 17: Associated monitoring costs based of Rubin and McCoy (2005) estimates	69
Table 18: Ten year Combined Cost Analysis	70
Table 19: 30 year Combined Cost Analysis	71
Table 20: Case study input parameters and distributions for the transport models	73

Chapter 1: Introduction

1.1 Problem Statement

An assessment of the implementation of retrofitting and sequestration technologies on a 572MW coal plant in Shawville, PA for Carbon Capture and Storage (CCS) and Enhanced Oil Recovery (EOR) to make the project viable while reducing associated costs.

1.2 Overview

To mitigate the effects of climate change, carbon reduction strategies have been proposed to reduce anthropogenic emissions of green house gases due to fossil fuel use. Geologic sequestration of carbon dioxide (CO₂) may serve as a short-term solution to this long-term issue of increasing atmospheric CO₂ concentrations until alternative forms of energy beyond fossil fuels are proven economically feasible. The driver towards developing and implementing carbon sequestration strategies lies in new legislation in global and domestic policies. Carbon capture and storage (CCS) is poised as a potential mechanism to remove CO₂ before it is emitted into the atmosphere and transported through pipeline networks to a storage site. These transport networks are expensive and complex, and regional partnerships have been established to develop best management strategies for dealing with the long-term storage of CO₂. Geologic sequestration may represent the greatest strategy for the long-term storage of carbon dioxide because immense volumes of CO₂ can be stored in various underground formations. The costs associated with these technologies are extremely high, but there is an opportunity to reduce these costs through enhanced oil recovery via underground injection of carbon dioxide into poorly producing oil and natural gas reservoirs. Carbon capture and storage strategies will only be effective in the mitigation of carbon dioxide emissions if they are cost-effective and pose little risk to environmental and human health. Various monitoring strategies have been proposed to assess the short and long term effectiveness of these projects and reduce associated risks. Through this paper we will discuss the potential benefits, costs, associated risks and viability of retrofitting an existing power plant in Shawville, PA to progress CCS strategies beyond theory into real-world application.

Chapter 2: Policies and Regulations

2.1 Introduction [2.1] [2.2]

In today's globalized world, policies, regulations and laws are what drive changes significant enough to alter our society. With global warming as one of the most critical issue since the turn of the century, the United States, as the world leader, have been striving to come up with policies and regulations in order to reduce green house gas emissions. This had led to an increasing effort to propose new laws and acquire funding for Carbon capture and Storage (CCS) projects. Unfortunately, even with support from the private sector, CCS initiatives cannot be properly launched without the backings of the state and the government. In this section, key political factors that enable CCS to happen will be discussed and the pros and cons fully analyzed.

2.2 The Beginning of Regulations [2.13]

In 2007, the Supreme Court ruled that EPA must regulate greenhouse gas emissions, including CO₂. EPA initially claimed that it lacked authority under the Clean Air Act to regulate carbon dioxide and other greenhouse gases (GHGs) for climate change purposes. With the case decided at 5-4 in favor of regulating GHG, this was far from controversial and this sparked great interest in the nation that eventually becomes the start of house bills, discussion drafts and regulations in various states in the US.

Massachusetts v. Environmental Protection Agency	
	
Supreme Court of the United States	
Argued November 29, 2006 Decided April 2, 2007	
Full case name	<i>Massachusetts, et al., Petitioners v. Environmental Protection Agency, et al.</i>
Docket nos.	05-1120 ↗
Citations	549 U.S. 497; 127 S. Ct. 1438
Prior history	On writ of certiorari to the United States Court of Appeals for the District of Columbia Circuit
Holding	
Greenhouse gases are air pollutants, and the United States Environmental Protection Agency may regulate their emission	

Figure 2: Massachusetts v. Environmental Protection Agency Supreme Court case

2.3 Stake Holders [2.1] [2.2] [2.3] [2.4] [2.9]

To better understand policies related to CCS, we must first be fully aware of all the stake holders. The following is a list of parties involved in CCS projects that must be considered:

- 1.) Energy Generation Sector
- 2.) State of Pennsylvania
- 3.) U.S. Environmental Protection Agency (EPA)
- 4.) Supreme Court and Obama Administration
- 5.) Residents of the USA (such as the farmer depicted below)

6.) Organizations supporting CCS

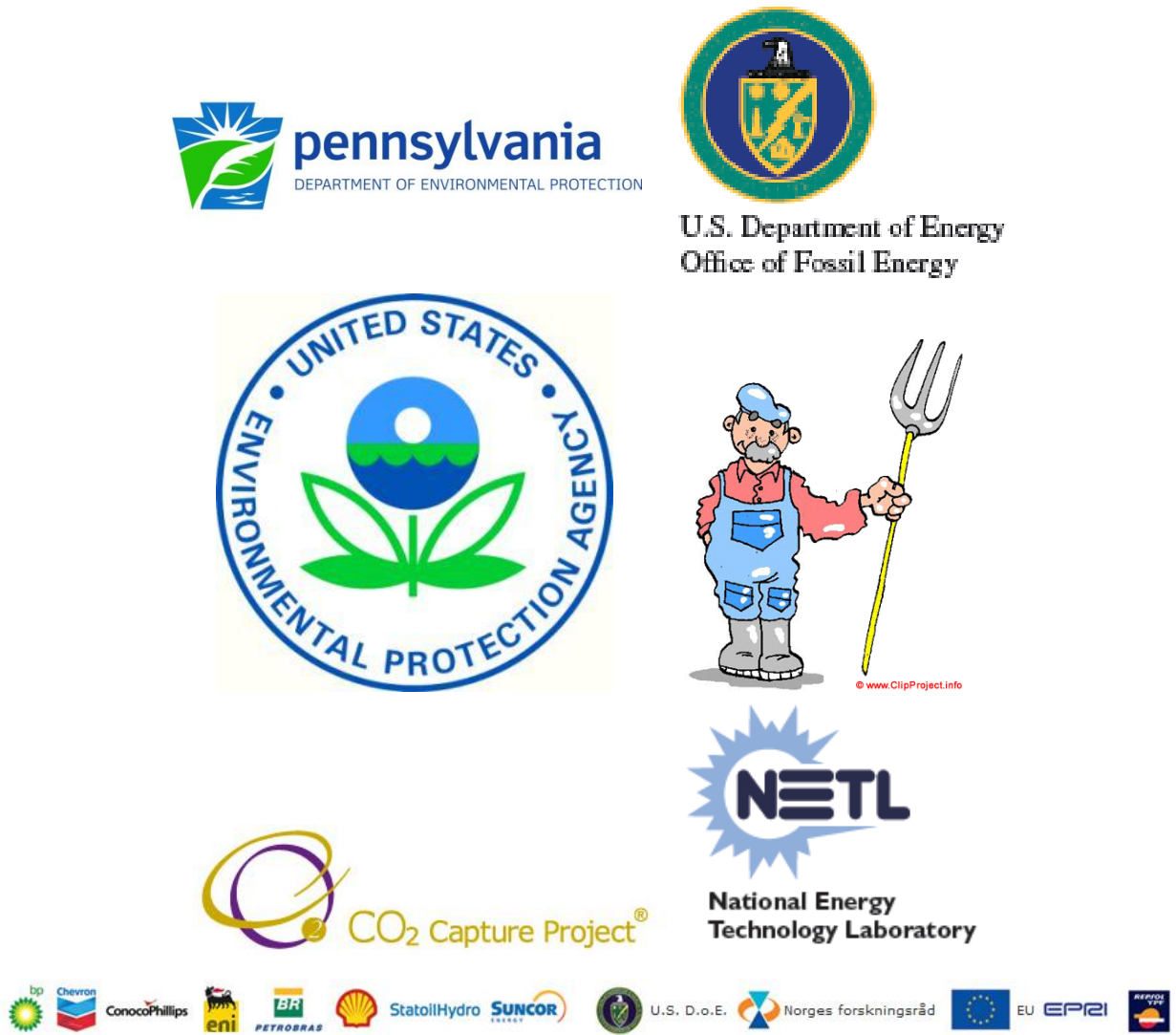

Figure 3: Logos and diagrams of CCS stake holders

In 2007, the Supreme Court ruled that EPA must regulate greenhouse gas emissions, including CO2. This has led to several initiatives from the EPA, some are listed below

- Clean Energy-Environment State Partnership
- Climate Leaders
- Combined Heat and Power (CHP) Partnership
- ENERGY STAR



The most relevant to CCS:

Tax Incentives to Reduce Greenhouse Gas Emissions

The following is taken from the EPA website:

<http://www.epa.gov/climatechange/policy/neartermghgreduction.html>

“The factsheet *Energy Provisions of the American Recovery and Reinvestment Act of 2009 (ARRA or Recovery Act)* provides information on the tax incentives for both individuals and businesses. The incentives are designed to spur the use of cleaner, renewable energy and more energy-efficient technologies that reduce greenhouse gas emissions. The tax incentives include: an increase in the energy tax credit for homeowners who make energy efficient improvements to their existing homes; credits to purchase for qualified residential alternative energy equipment, such as solar hot water heaters, geothermal heat pumps and wind turbines; and plug-in electric drive vehicles. The new law also includes increases to new clean renewable energy bonds and qualified energy conservation bonds. These are just a few of the energy provisions listed. The EPA web site contains more information on the Recovery Act, especially Clean Diesel.”

2.4 The Cap-and-Trade Program [2.5] [2.6] [2.7] [2.10]

Cap and Trade, also known as Emissions trading is:

- > **An administrative approach used to control pollution by providing economic incentives for achieving reductions in the emissions of pollutants.**
- > Government sets a national limit (**CAP**) for emission amounts then distributes to companies the rights (allowances) to emit gases (mainly CO₂). Companies are then free to buy and sell (**TRADE**) these allowances. Entities that emit more will have to pay more, thus providing them financial incentive to reduce emission.

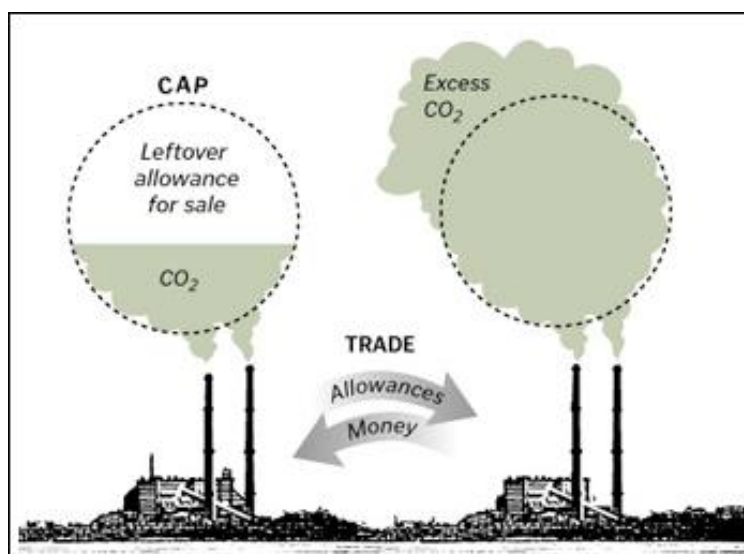

Figure 4: Cap-and-Trade Cycle

One of the two pieces of legislation currently being proposed in Congress is what is sometimes called “Cap and Trade”. This Cap-and-Trade’s House version is called the American Clean Energy and Security Act of 2009 and the Senate version, of the same bill, is the Clean Energy Jobs and American Power Act. The American Clean Energy and Security Act (H.R. 2454) , a cap-and-trade bill, was passed on June 26, 2009, in the House of Representatives by a vote of 219-212. The bill originated in the House Energy and Commerce Committee and was introduced by Rep. Henry A. Waxman and Rep. Edward J. Markey. This act also states the required GHG emission reduction target per year as follow:

Table 1: GHG emission reduction targets

Year	Required GHG Emission Reduction
2012	3.0%
2020	17.0%
2030	42.0%
2050	83.0%

As with all policies, there are benefits and drawbacks that must be considered and since the bills are viewable by the public the pros and cons as analyzed by policy makers and analysts can be summarized below:

Table 2: Pros and Cons for Legislation

Pros	Cons
Reduce CO ₂ emissions	Higher electricity bills
Viewed as “greener”	Higher gas prices
Cleaner Air and Environment	Little impact on climate change
Create jobs	Damage to economy
	India/China might not follow through

Some have also questioned the motive of cap-and-trade policies as merely money making tools for the government as well. There is the theory that coal-fired power plant needs to feed a certain amount of coal to keep the turbine/generator complex spinning at 3,600RPM and that means the CO₂ emissions at this level is unavoidable. The argument is that by placing a cap on emissions that are lower than this ‘minimum operational limit’ will simply result in either the plant shutting down or the plant paying the

fees for going over the limit, and it ends up as a money-making scheme for the government. Inevitably, the energy companies will not absorb all that cost and will pass on the costs to the consumer, resulting in a significantly increase energy bill.

In addition, Pennsylvania was reported by the American Legislative Exchange Council as one of the top five states that would be most negatively affected by cap-and-trade. This stems from the fact that the agricultural industry still dominates Pennsylvania, and since farmers are already struggling with low produce prices the rise in fuel/gas prices used to power their equipment would be a huge setback. This leads to an increase in agricultural product prices, lessens the purchasing capabilities of consumers, forcing them to save more money and thus reducing the economy's aggregate demand. With the fall in consumer demands, manufacturers will cut back on production and reduce the needs for electricity. This goes back in full circle since with the fall in energy demand, less coal is needed which will drastically affect the PA coal industry.

But why is CCS such a key project in Pennsylvania?

This is because the largest single source of GHG in PA is from coal burning power utilities. In the year 2000, this sector produced 116.2 MMt CO₂ (equivalent), which is 37% of the state's emission



Figure 5: Coal-fired Power Plant in Pennsylvania

2.5 Worries on Geologic Sequestration [2.1] [2.2]

Geologic sequestration brings about new legal/regulatory issues in Pennsylvania. In a state where land ownership is already complex enough, debate rages on whether the land beneath the surface is owned by the land owner or the state. Then there is the transportation pipelines that will need to connect the power plants to the sequestration sites. In addition, the underground injection must be well planned; regulated and long term storage must be considered. Finally, the risk of underground water contamination and protection of natural resources must be taken into account.

2.6 Climate Change Action Plan [2.3] [2.11]

The figure below (figure 6) includes states where Climate Change Action Plan is initiated, and Pennsylvania is seen to contribute 1% of the world's CO₂ emission and 4% of the USA's.

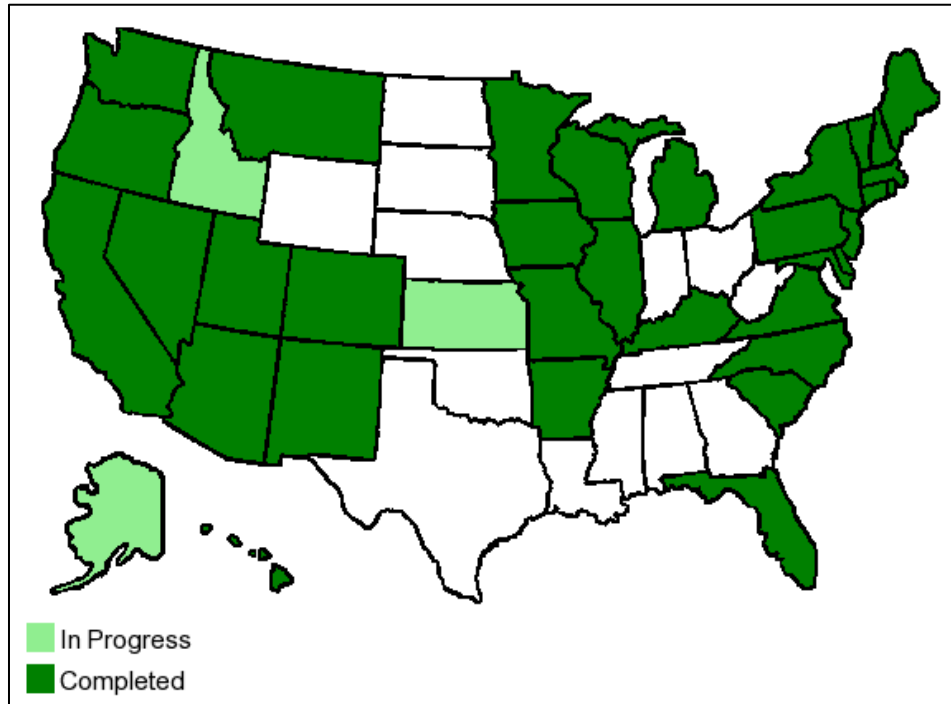

Figure 6: U.S. Map of states with climate change action plan or initiative

On July 9, 2008, Governor Rendell signed the Pennsylvania Climate Change Act (Act 70). On October 15, 2008, Governor Rendell signed into law House Bill 2200, which requires the Department of Conservation and Natural Resources (DCNR) to conduct studies of carbon capture and sequestration, and present its findings to the Governor and the General Assembly by mid-to-late 2009.



Figure 7: Pennsylvania State Capitol building

This results in Pennsylvania pushing hard to realize their Climate Change Action Plan, a comprehensive plan to 'reduce greenhouse emissions by as low as 30 percent of year 2000's level if all the 52 recommendations are heeded.

The studies under House Bill 2200 will include:

(1) Identification of suitable geological formations for the location of a CO₂ sequestration network (due May 1, 2009)

(2) An independent assessment (due November 1, 2009) of the following:

- Costs to establish, operate, and maintain CO sequestration network.*
- Safety and potential risk to individuals, property, and the environment associated with the geological sequestration of CO₂.*
- Existing federal and state regulatory standards for the storage of CO₂.*
- Factors contained in the U.S. EPA's vulnerability evaluation framework for geologic sequestration of CO₂.*
- Different types of insurance, bonds, other instruments and recommended levels of insurance which should be carried by an operator of a state network during construction and operation, and availability of commercial insurance.*
- Models for the establishment of a commonwealth fund to provide protection against risk.*

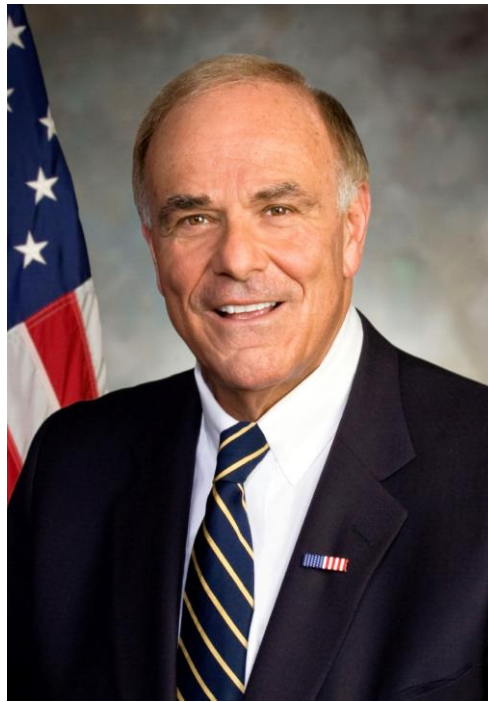

Figure 8: Governor Edward G. Rendell

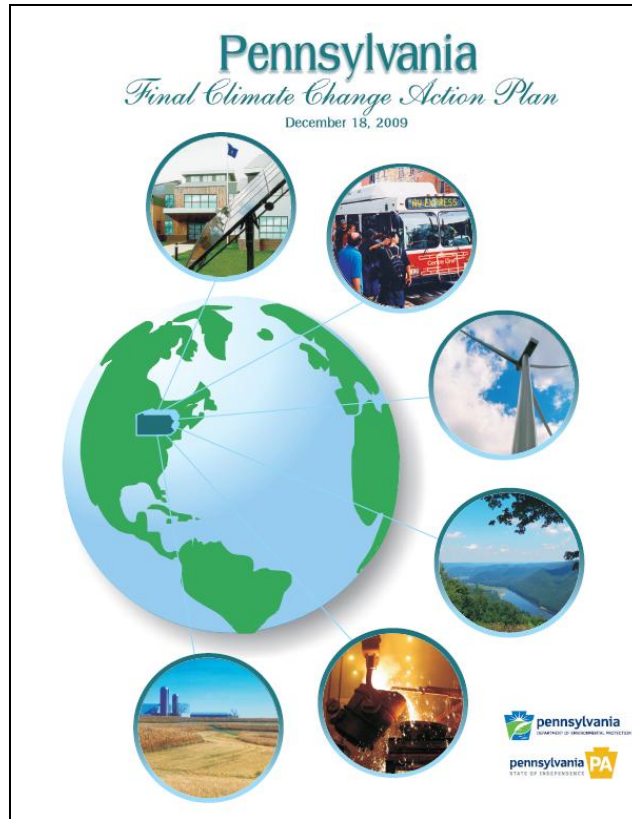

Figure 9: Cover page of the Climate Change Action Plan

The Climate Change Action Plan contains 52 recommendations to mitigate GHGs. The following is part of the CCS plan as stated in the Climate Change Action Plan:

Carbon Capture and Sequestration in 2014

The work plan entails carbon capture retrofit to existing supercritical pulverized coal plants starting in 2015 through 2019. In addition, the work plan calls for installation of an integrated coal gasification combined-cycle (IGCC) plant in the state in 2020. Retrofits of existing supercritical pulverized coal plants entail amine scrubbing with a CO₂ capture rate of 90% and an increase in heat rate (a decrease in efficiency). The reduction in efficiency results because the amine-scrubbing system diverts steam for power generation or consumes additional power for CO₂ compression. IGCC power plants use coal to produce electricity. The technology is based around a gasifier that produces a mixture of hydrogen and carbon monoxide called syngas. This syngas is burned in a gas turbine that is used to drive a generator. IGCC technologies with CO₂ capture are equipped with three more processes than the conventional IGCC technology without capture. The first is a process of reacting syngas with steam to produce CO₂ and hydrogen through shift reactors. The second process separates the CO₂ from the remaining gas. The final process compresses and dries the CO₂. Adding CO₂ capture technology to IGCC plants significantly reduces overall plant efficiency. Twenty of the 21 CCAC members approved and 1 member disapproved of recommending this work plan to DEP for including it in Pennsylvania’s Climate Action Plan.

The above section describes the plan for CCS in the year 2014 and mentions of the use of amine-scrubbing system; this will be analyzed in the next chapter.

House Bill 80

HB 80 is currently under consideration and will involve CO₂ indemnification funds, providing sequestration and transport pipeline facilities amongst others. The Climate Change Action Plan states on this bill: Implementation of the Carbon Capture and Sequestration (CCS) would be supported via passage of House Bill 80. DEP and DCNR are working collectively with a varied group of stakeholders, and the Clinton Foundation, to hasten the commercial deployment of CCS in PA.

This bill has been under review for a considerable amount of time and has come under heavy criticism for the wording used in the bill.

- 1.) The wording on the bill suggests that in the event a viable sequestration network is not, or cannot be developed, coal-fired power plants that have already installed carbon capture technology would still receive credits for CCS, even though it did not actually sequester the captured CO₂. This totally defeats the main purpose of the bill which is to reduce CO₂ emissions. It could even create a situation where new coal-fired plants are built with just capturing technology and no sequestration technology since it is not required in order to receive credits. The solution would be to make sure that a sequestration network is in place before coming up with any credit program.
- 2.) The state assuming liability for 1st sequestration site rather than energy generator. Since the liability for a CCS project is unknown because none have been performed commercially before, it is too risky for the state and PA taxpayers to assume liability.

2.7 Policy-related Commercial Terms [2.2] [2.4] [2.8] [2.12]

The main driving force behind a successful project is a successful negotiation with the commercial considerations. And what better way to give a project that extra kick when there are regulatory policies backing it? With such a backup, the owners of a power generation plant maybe better equipped to decide on how and when to retrofit their existing plant with CCS. This is because regulations like cap-and-trade or tax credits will empower the sector with funds for capital investments, bonus incentives and cost mitigations. This section will analyze a variety of opportunities for power plant owners to reduce their financial risks.

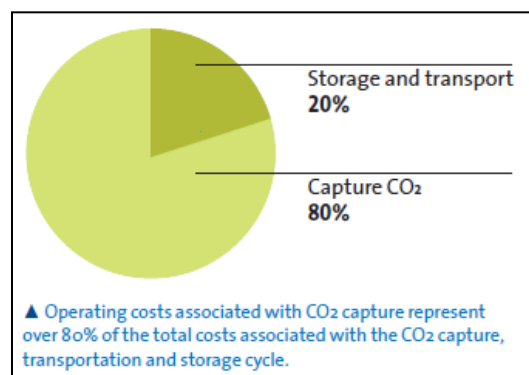

Figure 10: CO₂ Capture Project Brochure

Federal sequestration tax credit and investment tax credit for CO₂ pipelines:

-15% of costs incurred in EOR/EGR (IRS Form 8830)

- Renewable Electricity Production Credit (REPC), currently, the REPC for these technologies is 1.9 cents per kWh (CCSReg Interim Report)

-\$16 per ton of avoided CO₂ for a federal production tax credit including avoided SO₂, NO_x and mercury emissions (CCSReg Interim Report)

Dingell-Boucher – discussion draft:

This latest cap-and-trade program regulates coal downstream, right where the source of emissions is. CCS projects are also responsible for any leakages occurring from the project. The equation goes like this: \$90 per ton for early projects, eventually dropping to \$50 per ton (Available for the first 10 yrs of operation)

$$\frac{(\text{Tonnes of CO}_2 \text{ emissions avoided})(\text{bonus allowance value})}{\text{Average value of an emission allowance during the preceding year}} \quad (1)$$

This discussion draft was chosen as the policy backing this project due to the favorable support it gives CCS projects and because it was proposed by two very respectable people: U.S. Representative John Dingell (D-Michigan), chairman of the U.S. House of Representatives Energy and Commerce Committee (E&C) and Rep. Rick Boucher (R-Virginia), chairman of the Energy and Air Quality subcommittee of E&C. The draft has also been widely-reviewed by many organizations, including NRDC, Lots of Environmental Groups, Rep. Edward J. Markey (D-Mass.), Chairman of the Select Committee on Energy Independence and Global Warming and a senior member of the House Energy and Commerce Committee, Wilderness Society, and Greenpeace. Even though the reviews were mixed, most appreciate that this bill is the foundation of future drafts or versions that will eventually govern CCS in the future.

Considerations for Utilization of CO₂

There are considerations to be taken when categorizing CO₂ as “waste” or “merchandise”. In an EOR/EGR project this is clearly categorized as “merchandise” and state and federal laws are being proposed that will determine tax policies regulating uses for CO₂ in cases like this. The price of CO₂ then becomes a big factor and the market for CO₂ will need to be analyzed.

2.8 The future of CCS [2.9]

Amidst all the pros and cons, house bills and discussion drafts, numerous stake holders and renewed government funding, the big question to ask is “Is there a future for CCS?”

In September 2009, a demonstration projects in West Virginia by American Electric Power proved that CCS is a technological success. However, this does not prove that CCS will become a commercial success or even feasible in other parts of the country. This is because CCS requires a sequestration site that is determined by availability of geologic formation that is suitable for storage. Unfortunately, such a site is not always available within a reasonable distance from coal-fired power plants. Extended pipelines could be used to alleviate this problem but, as will be discussed in the transportation section, this comes at a huge cost.

Carbon capture and storage is also directly competing with other alternative energy resources such as wind and solar. If solar technology/commercial-ability reaches a level where it can compensate for coal-fired sources, then coal-usage would decrease, reducing the need for CCS projects in the first place.

According to PennEnvironment, Greenpeace and the European Renewable Energy Council have also released a report in March, 2010 that the US can cut GHG emissions by 85% by 2050 without having to rely on CCS while doing it at half the cost and twice the job creation.

So is there a future for CCS? There is no definite answer for that, but one thing that is certain is that it cannot be done without supporting policies and regulations.

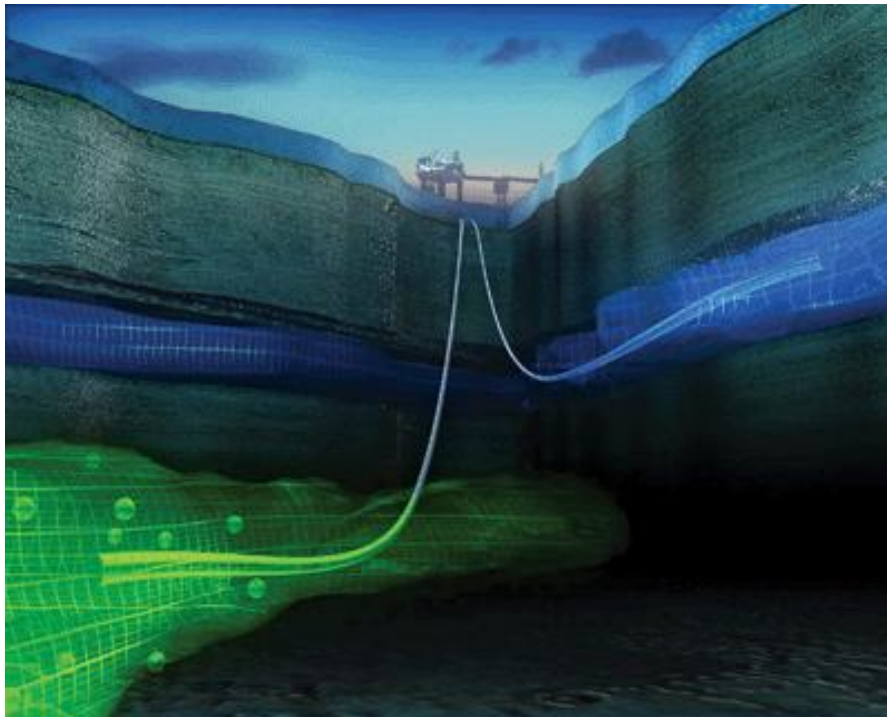

Figure 11: Computer-Generated cross section of a sequestration site (Energy Tribune)

Chapter 3: Retrofitting of an Existing Power Plant

3.1 Shawville Power Plant Specifications:^[3.1]

The Shawville Generation Station is a pulverized coal (PC) power plant operated by Reliant Energy Mid-Atlantic PH LLC. It is located in Clearfield County, Pennsylvania on 947-acres along the Susquehanna River. There are four steam boilers, two front wall-fired units in operation since 1954 and two tangentially-fired twin furnace units in operation since 1959 and 1960, with a total generating capacity of 572 megawatts (MW).[3.1] Each boiler is equipped with low NO_x burner technology and has been in compliance with regulated emission standards since 1996. Cooling water is obtained from the Susquehanna River at a rate of 535 cubic feet per second, cooling the flue gas to an average exit

temperature of 149°C. Electrostatic precipitators have been utilized since 1976, and the plant still meets the particulate emission standards of 0.1 lb/mm Btu. Fly ash and bottom ash are land filled on-site.[3.1]

The plant consumes 1.4 million tons of Pennsylvania bituminous coal per year. This coal has a higher heating value (HHV) of 11,987 Btu/lb, an ash content of 13.86%, and a sulfur content of 1.78%. This equates to 33.9 trillion Btu/yr of input heat content. Comparing this to the 3.2 million MWh of net annual electrical generation provides a plant thermal efficiency factor of 32.2%, on a HHV basis. Average sulfur dioxide (SO₂) emissions are in the range of 2.73-2.81 lb/mm Btu, which meets the 3.7 lb/mm Btu EPA emission standard. Annual carbon dioxide (CO₂) emissions from the Shawville plant, as reported by the EPA in 2005, are 3.4 million tons.[3.1]

3.2 Carbon capture technologies: [3.2], [3.3]

There are three different approaches that can be utilized for the capture of CO₂ from coal power generation facilities: post combustion capture, pre-combustion capture, and oxy-combustion. Post combustion capture separates the CO₂ from the other constituents of the flue gases. A gasifier utilizing water-gas-shift is the pre-combustion capture pathway, while oxy-combustion uses an air separation unit to burn the coal in a concentrated oxygen stream in order to produce a concentrated stream of CO₂. Since pre-combustion capture technologies apply to gasifier units it will not be considered for application to the Shawville PC steam generation plant.

3.2.1 Post-combustion capture

Post-combustion capture is appropriate for retrofitting air fired coal power plants. The flue gas stream from air fired plants typically contains a concentration of CO₂ less than 15%.[3.2] This low concentration stream requires large equipment to handle the high flow rate of gas which emerges from the system. The flue gases emerge from the system at ambient pressure, requiring high performance or circulation to obtain high capture rates and significant pressure steps to meet transport and sequestration requirements. Options available for post-combustion CO₂ capture are discussed in detail below.

3.2.1.1 Amine-based absorbents

Chemical solvent scrubbing using monoethanolamine (MEA) is the currently favored technique for post-combustion CO₂ capture. Amine scrubbing has over 60 years of use in industry, with CO₂ capture rates being observed between 85 and 95 per cent with a product purity of over 99%. Before introduction to the solvent, the flue gas is cooled and particulates along with other impurities are removed. Degradation of the amine, along with corrosion of equipment, occurs from the reaction with SO_x, NO₂, and O₂. Typically the SO_x concentration needs to be less than 10 ppm, while selective catalytic reduction is necessary to obtain the low levels of NO₂ in order to decrease the rate of degradation.[3.2]

After the flue gas is cleaned and cooled, it is passed through a packed column with the MEA traveling counter-current to the flow. The acidic CO₂ absorbs into the basic solvent and is passed from the bottom of the column to another column where it is heated with steam and the CO₂ is stripped from the solvent. After the CO₂ is removed it is compressed for transport and the solvent is returned back to the absorption column. This process requires large equipment to handle the large volumes of flue gas coming from a power plant.[3.2]

Alternative amine based solvents are being developed to reduce the regeneration energy requirements, degradation, corrosiveness, and equipment size while increasing the capacity and rate of CO₂ absorption. Hindered amines, blends of MEA with other amines, and amino acid salts are all being studied; however the capital and operating costs along with costs for the solvents are currently more expensive than MEA.[3.3]

3.2.1.2 Aqueous ammonia absorption ^{[3.4], [3.5]}

Alstom has been developing a chilled ammonia process (CAP) which operates in a similar manner to the amine systems described above. The absorber operates at temperatures less than 10°C, requiring the flue gases to be cooled via chilled water and direct cooling units. The chemical absorption occurs in a column between ammonium carbonate (AC), CO₂ and water to form ammonium bicarbonate (ABC) precipitates.[3.4] These precipitates are then passed through a high pressure pump and moved into a regeneration unit, which acts much like a distillation column. Heat is applied to dissolve the ABC to produce gaseous CO₂, ammonia (NH₃), and water (H₂O). A water wash column is used to condense out the NH₃ and H₂O, from the now high purity CO₂ stream (>99.9%), and reform ammonia carbonate for re-use. The CO₂ product stream leaves the process at 435 psi, and is then compressed to 1500 psi for transport and storage.[3.4]

A 90% capture rate has been observed in single stage demonstration scale plants. It is important to keep the process operating below 10°C to ensure minimal ammonia slip, which will react with SO_x and NO_x in the cooling units to form ammonium sulfate and ammonium nitrate.[3.4] These are fertilizers which could be a salable by-product; however they will require additional solvent operation and maintenance costs. Operating at this low temperature enables the formation of solid ABC, as opposed to aqueous ABC, and increases the CO₂ capacity of the solution. Also, the moisture present in the flue gas condenses out and reduces the volumetric gas flow rate, increasing the concentration of CO₂ and reducing the size of absorber columns.

Alstom reports lower steam consumption in comparison to the MEA process of only 15% with a higher solvent loading, resulting in a thermal efficiency penalty of only 3.5% compared to MEA's 11.6%.[3.5] Table 3 shows the energy performance effects of CO₂ capture using MEA and NH₃ absorption. Verification of these savings needs to be preformed, due to the higher power consumption involved in refrigeration and flue gas fanning.

Table 3: PC Plant Energy Performance with and without CO₂ Capture Comparison [3.4]

	Supercritical PC Without CO ₂ Removal	SCPC With MEA CO ₂ Removal Parsons Study	SCPC With NH ₃ CO ₂ Removal Current Study
Coal Feed rate, lb/hr	333,542	333,542	333,542
Coal heating value, Btu/lb (HHV)	11,666	11,666	11,666
Boiler heat input, MMBtu	3,891	3,891	3,891
LP Steam extraction, lb/hr for reboiler	0	1,215,641	179,500
Steam Turbine Power, kWe	498,319	408,089	484,995
Generator loss, kWe	(7,211)	(5,835)	(7,018)
Gross plant, kWe	491,108	402,254	471,301
Plant Auxiliary Load (IDF, FGD, BFW pumps, Water pumps, Cooling Towers, CO ₂ unit, Chillers, CO ₂ compressor, BOP), kWe	(29,050)	(72,730)	(53,950)
Net Power Output	462,058	329,524	421,717
Net efficiency, % HHV	40.5	28.9	37.0
Avoided Cost, \$/ton CO ₂	Base	51.1	19.7

3.2.1.3 Membranes

There are several types of membranes being studied for the recovery of CO₂ from flue gas. Physical or chemical interactions drive the separation of gases via membrane material, allowing specific components to pass through the membrane more easily than others.[3.2] The more promising technologies for retrofitting include gas absorption membranes and inorganic membranes. Additional development is required in order to make membranes cost effective for large scale power plant CO₂ capture.

Gas absorption membranes allow for alternative solvent use which would otherwise be ineffective in gas and liquid direct contactors (adsorption systems). The concept passes flue gas through membrane tubes, while an amine solution collects permeating CO₂ on the other side of the membrane.[3.3] Impurities would be blocked by the membrane, reducing loss of amine through degradation while possibly increasing its loading capabilities. In order for this technology to be viable, selectivity and permeability of the membrane needs to be increased while decreasing the cost.

Inorganic membranes have been able to selectively separate CO₂ from methane (CH₄), which is useful for purifying natural gas streams. A microporous silica membrane containing amine functional groups is being developed for the separation of CO₂ from flue gas streams.[3.2] It is hypothesized that the amine functional pores and permeating CO₂ interactions will enhance the selective diffusion of CO₂ while blocking the other flue gases present from transferring through the membrane. These are still in the

laboratory phase of development, where increased membrane selectivity and permeability are the main focus.

3.2.1.4 Solid adsorbents ^[3.6]

Solid sorbents which can remove CO₂ at relatively high temperatures are being proposed for flue gas capture. By requiring smaller or no cooling units for capture onto the sorbents, there is potential for reducing efficiency penalties compared with absorption processes. Solid sorbents can be regenerated by applying heat, effectively liberating high purity CO₂ from the surface. Jones et al. has done extensive research on numerous adsorbent materials.[3.6] Figure 12 shows the ideal relationship between temperature and CO₂ loading for each of the adsorbents studied. It can be seen from the graph that zeolites, lithium zirconates, and amine impregnated structures along with organically-supported amines depict an acceptable range of capacity in relationship to temperature.

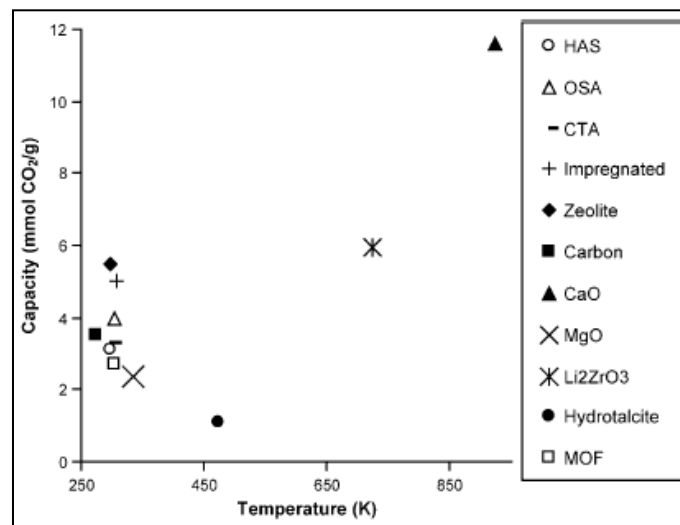

Figure 12: Highest reported CO₂ capacities of all solid adsorbent classes at different temperatures

Zeolites rank among the fastest known kinetic rates for CO₂ adsorption, enabling the material to load most of its capacity within seconds of being introduced to the stream. Ideal adsorption occurs at 0°C, and desorption of CO₂ from the surface occurs at temperatures higher than 120°C.[3.6] So, significant cooling and then reheating must occur in order for this structure to be utilized in power plants.

Lithium zirconates show high adsorption capacities of up to 4.5 mmol/g, high thermal stability at temperatures above 400°C, and regeneration characteristics better than other oxide adsorbents.[3.6] However, even at high temperatures it takes several hours and even days to become loaded with CO₂. Additional research is required in order to increase the kinetic adsorption rate in order to overcome this limit.

Amine enhanced adsorbents show the most promise as a near term capture technology. A general tradeoff occurs with the loading capacity and kinetic rate of adsorption, where a lower amine content normally decreases the capacity and a higher content decreases the adsorption rate. Impurities in the

flue gases will have the same effect on amine bound to adsorbants as it does on amine absorbant systems.[3.6]

Overall, additional research is necessary to increase adsorbent performance for their practical application to post-combustion CO₂ capture. Increased loading capacity along with adsorption rates need to be realized to be competitive with other technologies, in addition to studies to find the effects of typical flue gas constituents on reactivity and selectivity.

3.2.2 Oxy-combustion

Oxy-combustion is the burning of fuel in a pure oxygen stream, rather than in atmospheric air. Recirculation of the flue gases needs to occur in order to bring the flame temperature within the boilers down to normal air-blown temperatures. The main advantage of burning fuel in pure oxygen is that there is a lower flue gas volume which consists of concentrated CO₂ (about 80%).[3.2] Water can be condensed out of the flue gas stream, decreasing the volume and increasing the CO₂ concentration even more. This process is better suited for gas turbines, rather than coal combustion, since it contains fewer contaminants in the fuel stream.[3.3] For application to coal combustion power plants, the process requires extremely efficient contaminant gas removal in order to reach the high levels of purity obtained in post-combustion processes. The economic benefit of oxy-combustion is not evident for coal application, due to the large costs associated with air separation and flue gas recirculation on top of the purification technologies which also need to be implemented.[3.2]

3.3 Capture Technology Selection

Based on the literature review performed, the technology which appears to be best suited for CO₂ capture at the Shawville Generation Station is post-combustion capture utilizing the chilled ammonia process proposed by Alstom. However, the most developed and employed technology is the absorption method utilizing MEA. The CAP process, being in the pilot stage of development, lacks a supply of unbiased data. Following is a description of the analysis which was performed in order to select the more appropriate capture option between the two processes. For both of the processes it was assumed that a 90% capture rate would be accomplished with the equipment being operational at a 90% capacity factor. All costs are assumed to be in 2010 equivalent dollar amounts. Also, a levelized cost of power was assumed to be 6.5¢/kWh, and a capital charge factor of 0.175 was used [3.7].

3.3.1 Monoethanolamine Analysis

The first step into implementing an absorption system that operates with MEA is to build a flue gas desulfurization scrubber. Using an EPA fact sheet on scrubbers, capital cost and operations and maintenance costs of \$100/kW and \$22/kW, respectively, were used [3.8]. This amounts to a capital investment of \$40.5 million and \$8.9 million of annual operations and maintenance costs. The scrubber's power draw is assumed to be 1% of the total energy produced, which leaves the power plant with an output of 405.4 MW [3.8].

After the instillation of a scrubber occurs, the absorption and desorption units were evaluated. Information provided by the National Energy Technology Laboratory was used to determine the capital cost, operations and maintenance cost, and energy penalty associated with a MEA capture system.

Figure 13 below shows the relationships between the afore mentioned criteria and the amount of CO₂ captured. It can be seen that each shares a linear relationship to sizing conditions, and therefore a linear fit trend line is used to determine the Shawville site specific values. The capital cost of the MEA equipment at Shawville will cost \$406 million, with operations and maintenance costs of \$87.7 million. The equipment will incur a 10.7% energy penalty on the power plant, which will amount to a final power output of 258.1MW.

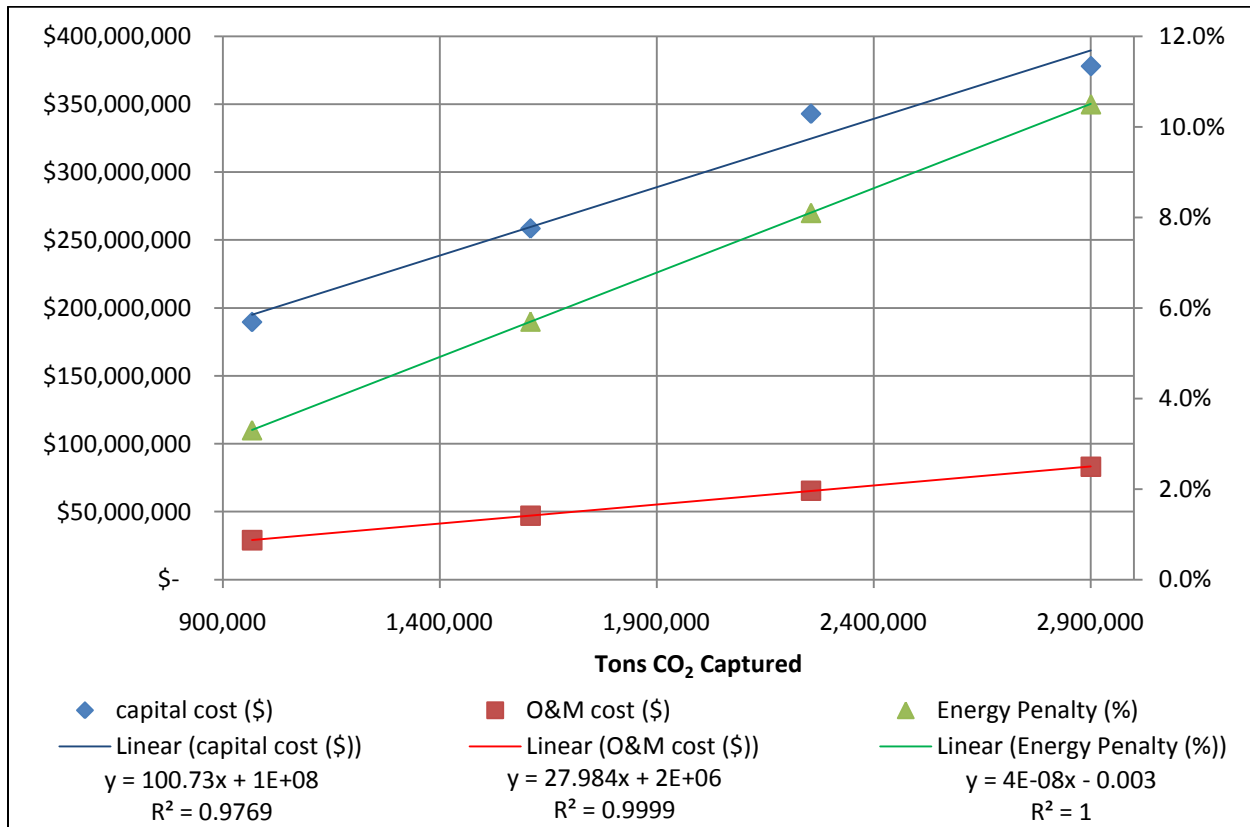

Figure 13: MEA Capture Cost and Energy Penalty Analysis

3.3.2 Chilled Ammonia Process Analysis

Due to the lack of detailed data for the chilled ammonia process available within literature, a model was drawn up in SuperPro Designer[®] and can be seen below in figure 14. Several assumptions were made in order to describe the model. First, a steady state analysis was performed using data from DOE/NETL and the flue gas composition was determined and can be seen in Table 4 below. These flue gases enter the direct contact water cooling tower at an average temperature of 149°C and exit at 23°C, and then they are chilled to 5°C. The gas stream is then passed through the absorber where it runs countercurrent to a 26%-wt ammonia solution. This solution contains the ammonia in the form of ammonium carbonate, and the reaction with carbon dioxide forms ammonium bicarbonate with an absorption of 0.10 kg CO₂/kg solution. The flue gases are then passed through a washing column to precipitate out any ammonia which may have escaped the system. Solid ABC is removed from the stock solution by hydrocyclone, and then pressurized to 435 psi and passed through a heat exchanger to obtain a temperature of 80°C. A reboiler produces steam for the stripper, which operates at 120°C, and

CO₂ is subsequently removed from the ABC to form AC once again. Another washing column is utilized to precipitate out any NH₃, and then the 99.9% purity CO₂ stream is sent to compression for transport.

Capital costs and operations and maintenance for this process, as determined by the software, are \$65.1 million and \$227.5 million, respectively. The equipment has a power load of 70 MW, which equates to a net energy penalty of 5.6%.

Table 4: Flue Gas Composition (w/out capture)

	mass flow rate		mass percentage
	kg/hr	ton/yr	
CO ₂	392,132	3,403,902	15.1%
SO _x	5,413	46,976	0.2%
NO _x	793	6,885	0.0%
H ₂ O	222,000	2,176,548	9.7%
N ₂	1,581,262	15,503,132	68.7%
O ₂	144,105	1,412,847	6.3%

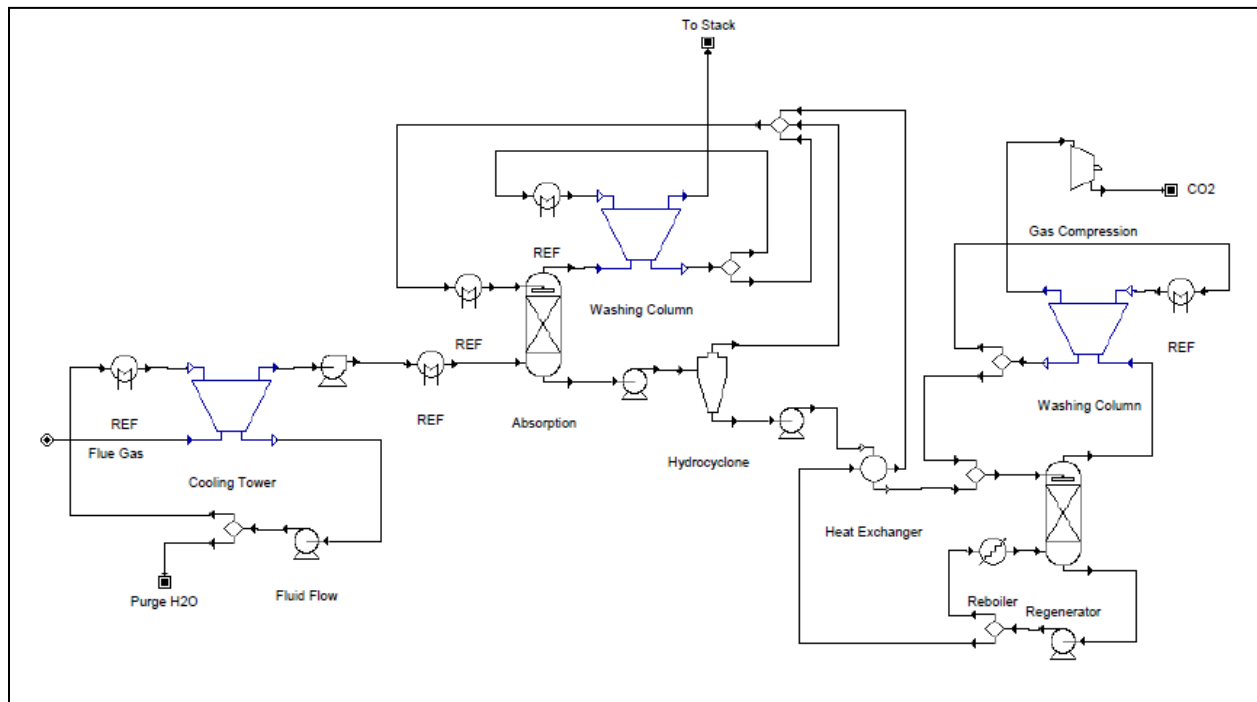

Figure 14: CAP flow diagram [SuperPro Designer®]

3.3.3 Summary and Comparison of Selected Technologies

After evaluation of the two most promising technologies for CO₂ capture, it is determined that a MEA system is the better option for application to the Shawville power plant. The MEA system, with flue gas desulfurization, incurs an 11.7% energy penalty compared to just 5.6% for the CAP system, which equates to a final power output of 258 MW and 335 MW for the respective technologies. Although this

analysis appears to show favor to the CAP absorber, the economics show favor to the MEA absorption system. The performance and cost analysis, applied to the Shawville power plant, can be seen in table 5 below. Due to the benefits seen for avoided cost per ton of CO₂ captured, the decision is to use MEA absorption for the analysis.

Table 5: Shawville Plant Performance with and without CO₂ Capture

	Base Plant	MEA w/ FGD	CAP
Energy Input (MW)	1259	1259	1259
Energy Output (MW)	405	258	335
Energy Penalty	-	11.7%	5.6%
η_{th} (% HHV)	32.2%	20.5%	26.6%
Capital Costs (MM \$)	-	446.6	65.1
O & M Cost (MM \$)	-	96.7	227.5
Avoided Cost, \$/ton CO₂	-	57.06	77.97
Price (¢/kWh)	6.5	14.99	15.44
Price Increase		57.3%	58.5%

3.3.4 Future Capture Work

For future evaluations, modeling both processes would be beneficial in order to get a better comparison of stored energy values and costs within the software. Also, Alstom is currently in the process of gathering research from their pilot scale plant, which should be analyzed and used in subsequent reports [3.4]. More selective absorbents than MEA have been discussed in literature, but they too need to be tested at the commercial scale before a conclusion can be drawn [3.2]. As reports develop and become available, it is important to analyze them for any bias which may be present. The energy penalty values obtained from this report for CAP are consistent with those found in literature; however they do not coincide with avoided costs as presented by Alstom, the exclusive owner of marketing and sale of the patented process [3.5].

Chapter 4: Transportation and Storage with cost estimation

4.1 Introduction

Carbon capture and storage (CCS) requires CO₂ to be captured from energy production process, compressed to high pressures, transported to a storage site and injection into a suitable geologic formation. Each of these steps is capital and energy intensive and will have a significant impact on the cost of energy production and ultimate benefits/goal of CO₂ reductions..

Our CCS project is based on the coal fired power plant (Shawville, PA, 572MW capacity) which is located in the Midwest Regional Carbon Sequestration Partnership (MRCSP) region. This study focused on the general geologic storage potential in the MRCSP region and hydraulic parameters of formations. We determine that the Rose Run formation is the best candidate for the storage with a potential capacity between 244 million tons and 1025 million tons.

Because of different pipeline transportation scenarios, this study's objective was to maximize any related benefits and to compare the economic cost results of two storage sites. The first one is to inject CO₂ into the formation underlying the power plant with a radius of 25 miles and the second scenarios is for EOR purposes 250 miles away from the power plant.

4.2 Geological CO₂ Sequestration Opportunities in the MRCSP

4.2.1 A Snapshot of the MRCSP

The Midwest Regional Carbon Sequestration Partnership (MRCSP) is a public/private consortium that is assessing the technical potential, economic viability, and public acceptability of carbon sequestration within its region. The MRCSP region consists of seven contiguous states: Indiana, Kentucky, Maryland, Michigan, Ohio, Pennsylvania, and West Virginia. A group of leading universities, state geological surveys, nongovernmental organizations and private companies listed below and led by Battelle, compose the MRCSP. It is one of seven such partnerships across the U.S. that makes up the U.S. DOE Regional Carbon Sequestration Partnership Program. [4.1]

- Population: 50.8 million (1 in 6 Americans)
- Gross Regional Product: \$1,534 billion (1/6 U.S. economy)
- 21.5 % of all electricity generated in the U.S.
- 77 % of electricity generated in the Region is generated by coal.
- 12 % of nation's total CO₂ emissions.

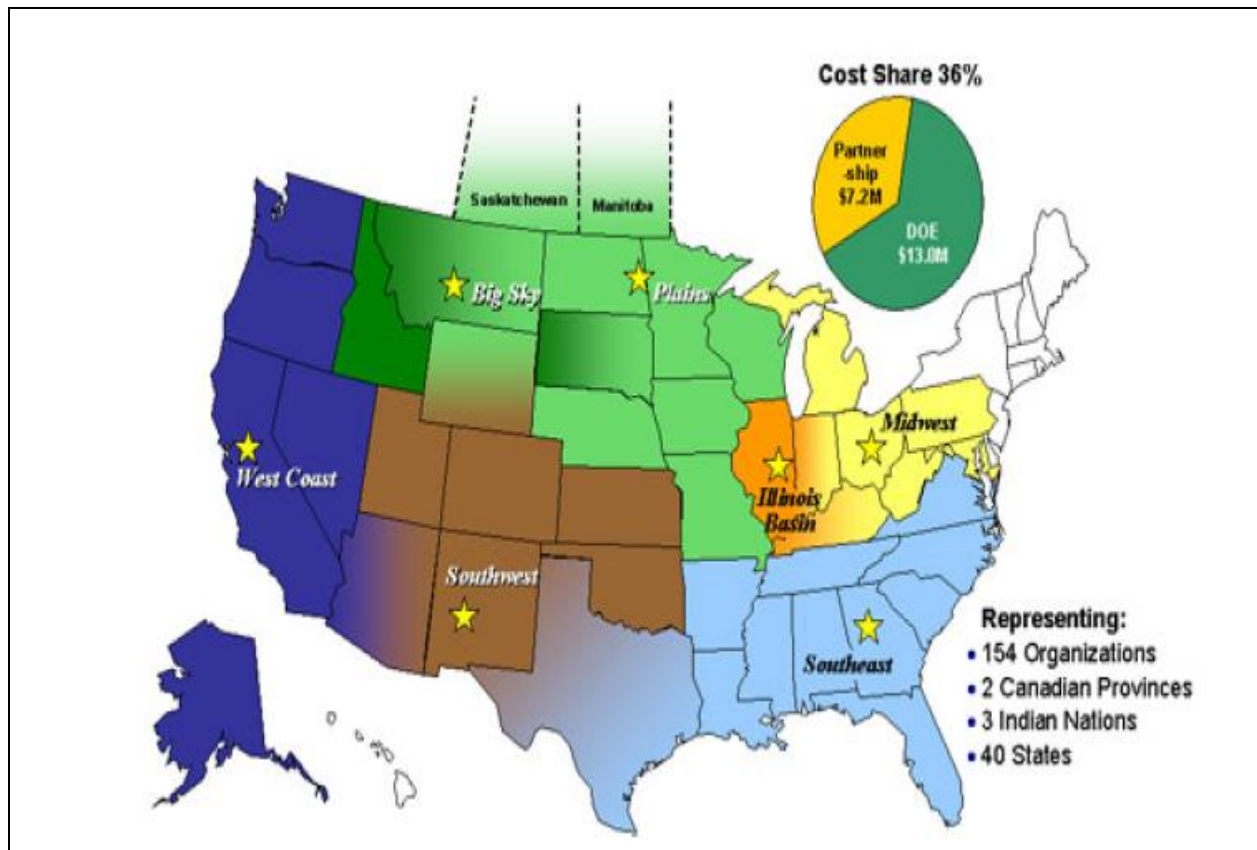

Figure 15: Makeup of the Seven DOE Regional Partnerships (c. September 2005)

The MRCSP region’s geology is diverse, encompassing the Northern Appalachian Basin, the Atlantic Coastal Plain, the Michigan Basin, and the Arches Province. The geologic sequestration options of the region are many and varied, including numerous deep saline formations (DSF) available across much of the region, large active and depleted oil and gas fields in the Michigan Basin and the Northern Appalachian Basin, and one of the nation’s largest accumulations of coal in the Northern Appalachian Basin. [4.1]

This MRCSP region has more than 500 gigatons of geologic CO₂ storage potential (GtCO₂). This is an immense natural resource that could accommodate many hundreds of year’s worth of current CO₂ emissions from the region’s large point sources such as electric power plants, cement plants, and refineries. [4.1]

The MRCSP Phase I geologic characterization efforts focused primarily on four reservoir classes: deep saline formations, oil and gas fields, unmineable coalbeds, and organic shales (in laboratory scale). [4.1]

Based on the MRCSP’s analysis to date, the MRCSP Region’s deep saline formations hold the greatest potential to store large quantities of CO₂.

The deep saline formations, especially Mt. Simon, St. Peter and Rose Run sandstones are by far, the region's largest assets for long-term geologic CO₂ sequestration. The region's deep saline formations could potentially store 450-500 GtCO₂.

There is at least 2.5 Gt CO₂ of potential storage capacity in existing and depleted oil and gas fields. Storing CO₂ in these formations via enhanced oil recovery methods in current and recently abandoned regional oil fields could lead to the production of potentially hundreds of millions of barrels of additional oil production.

Not only is there tremendous potential for carbon sequestration technologies to deploy in the future within the MRCSP, but at a very real level, one can say this is already happening and that the MRCSP region represents one of the leading locations worldwide for the early implementation of these critical carbon management technologies. The MRCSP Region is home to: [4.2]

- The world's first geologic storage experiment located at an operational power plant (the Mountaineer coal-fired power plant),
- One commercial power plant that is already capturing CO₂ with an amine scrubber (the AES Warrior Run coal-fired power plant) and at least, three commercial IGCC units in advanced stages of planning are likely to be built in the region.
- More than 10 miles of dedicated CO₂ pipelines are serving commercial CO₂-driven enhanced oil recovery in Michigan.
- The region has an extensive history of restoring mine lands and already has commercial experience with implementing no-till agricultural methods and other promising terrestrial sequestration options.

4.2.2 General geologic storage potential in MRCSP

MRCSP Oil and Gas Reservoirs [4.3]

The MRCSP Region has many opportunities for CO₂ sequestration in oil and gas reservoirs. Exploration for oil in the Region began in 1859 with the discovery of oil by Colonel Drake in Oil City, Pennsylvania. In addition, significant amounts of natural gas are stored in the region. Such large volumes of gas storage capacity (both natural and engineered) strongly suggest that CO₂ gas can be successfully managed in subsurface reservoirs within the region. The oil and gas fields in the region are most concentrated in the Appalachian and Michigan sedimentary basins. Research suggests that oil and gas fields have a potential sequestration capacity of at least 2,760 million tons of CO₂. Much of this capacity is intermixed with deep saline formations. In fact, it may be difficult to differentiate the two formations in many areas.

Key oil and gas rock formations in the Appalachian Basin include Devonian shales, "Clinton"/Medina/Tuscarora sandstones, the Oriskany sandstone, and the Rose Run sandstone.

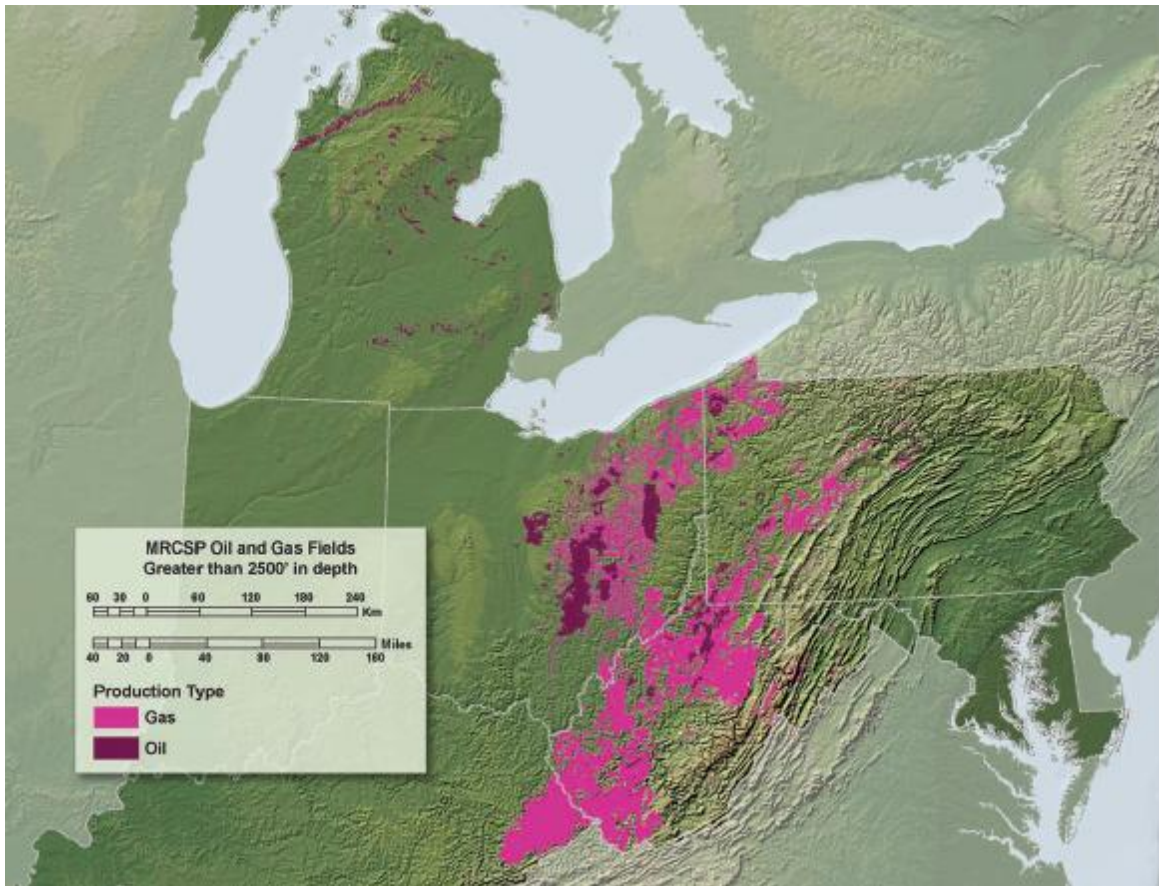

Figure 16: MRCSP Oil and Gas Fields as targets for carbon sequestration

MRCSP Deep Saline Formations [4.3]

Deep saline rock formations are, by far, the MRCSP Region's largest assets for long-term geologic CO₂ sequestration. Initial mapping indicates that the region's well-defined deep saline formations could potentially sequester up to 208,000 million tons of CO₂. The estimated CO₂ storage capacity for the Region is very large compared to present-day emissions, enough to accommodate CO₂ emissions from large stationary sources in the region for hundreds of years. Saline formations in the MRCSP Region are widespread, close to many large CO₂ sources, and are thought to have large pore volumes available for injection use. The region is additionally considered a fairly stable geologic setting.

The storage capacity in each reservoir is largely a function of its spatial extent, thickness, and porosity. Given its presence in much of the MRCSP Region, the saline formation with the largest capacity in the Region is the Mt. Simon Sandstone, followed by the St. Peter Sandstone and the Medina/Tuscarora Sandstone. Other notable target formations include the Rose Run Sandstone, the Oriskany Sandstone, and the Sylvania Sandstone. While Michigan has the highest storage potential, all of the seven states in the MRCSP Region have the capacity to store large amounts of CO₂ in deep saline formations.

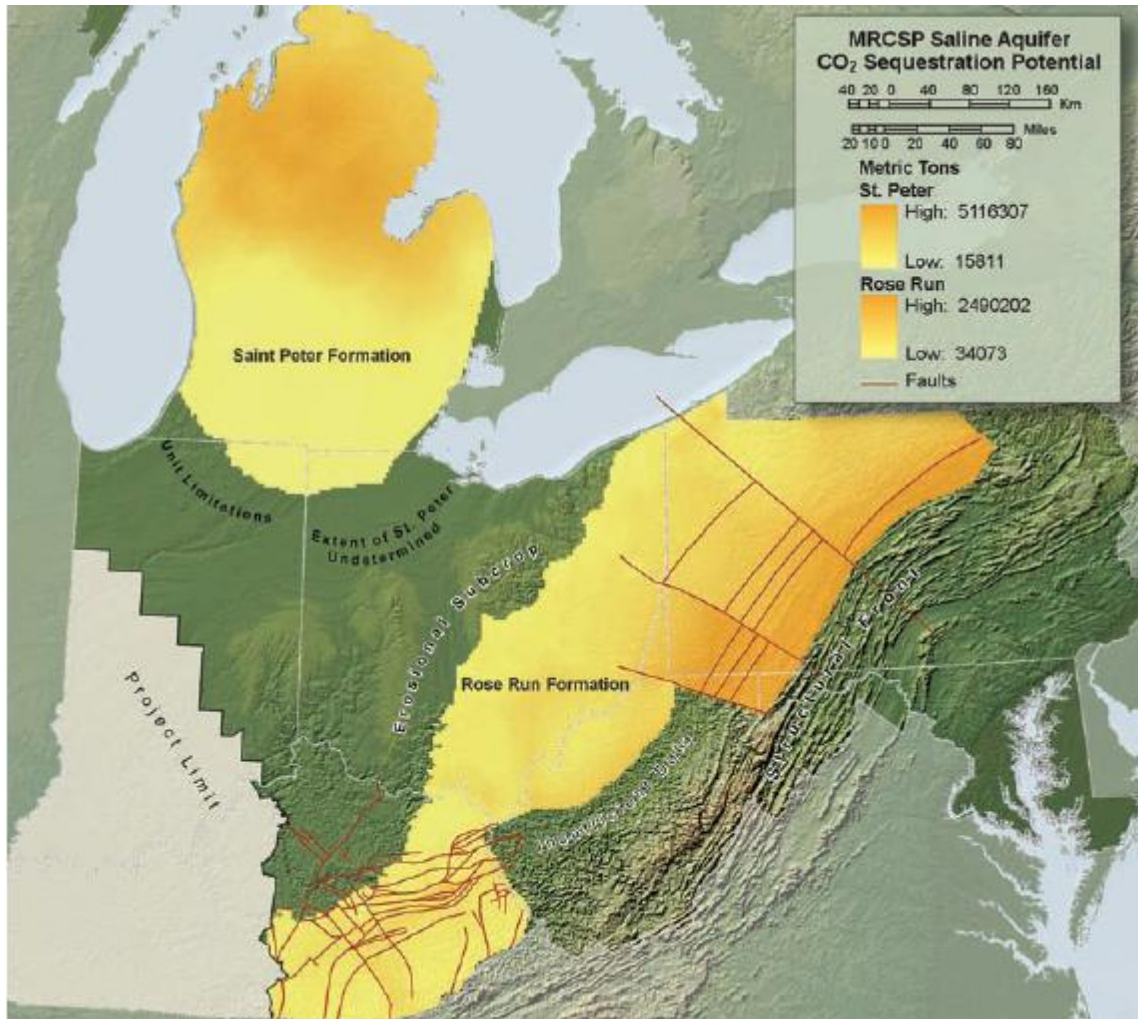

Figure 17: Saint Peter and Rose Run formations

4.3 Carbon Storage Site Selection---Rose Run

4.3.1 Deep Hydrostratigraphic Unit

The Rose Run sandstone is located across Ohio, Pennsylvania, Kentucky, West Virginia and Maryland. It crops out in eastern of Ohio. Suitable formations for geologic storage of CO₂ are deep, thick, regions that are regionally extensive, filled with saline waters, and separated from freshwater aquifers and other formations of economic interest by a significant interval of low permeability cap-rock. For CO₂ disposal applications, a minimum depth of approximately 2,500 ft is required to maintain the pressure for retaining CO₂ in a dense, supercritical fluid phase. [4.4]

Supercritical CO₂ has a density of approximately 0.7, and formation fluids have a density of approximately 1.05 to 1.25. Consequently, the injected CO₂ is expected to move upward within the formations due to density-driven flow.

Shale, limestone, and dolomite layers form the major containment units to limit vertical migration of any injected CO₂. The Beekmantown, Black River, and Reedsville provide containment above the Rose

Run Sandstone. The Beekmantown is a dense dolomite and the Black River is a limestone and dolomite mixture, with a combined thickness of 1,400 ft. The Reedsville is uniform shale, which is considered an excellent confining layer. The shale formations have very low effective porosity of <1% and permeability is often below 1E-6 mD. In general, containment units appear to be present above the target injection layers that are more than adequate to prevent any upward migration of CO₂. [4.5]

According to the research, the containment unit of the Rose Run is approximately 200 ft thick and primarily shale with very low permeability and porosity. [4.5] Also, containment layers are diverse and extensive. This is exemplified by the presence of oil and natural gas production and underground waste disposal and natural gas storage facilities that utilize the Rose Run sandstones, as well as several other formations. This suggests an excellent setting for long-term storage of CO₂. [4.4]

In addition, the overlying containment units separate the injection intervals from any underground sources of drinking water (USCWs).[4.5]

4.3.2 Hydraulic Parameters

The main hydraulic parameters measured in formations are permeability and porosity (Table 6). A review of the data illustrates that the parameters are very site-specific. Permeability, especially, may vary over several orders of magnitude within a formation due to variations in the nature of the rock. Porosity is generally more consistent. [4.5] The testing method also can have a large impact on results.

Our CCS project sequestration site is base on two scenarios. One scenario is the storage underlying our Shawville plant with a radius of 25 miles. Another scenario is to the depleted oil and gas reservoir using (EGR) model. We determine the Colfax Field located in Fairfield County, OH. The potential sequestration sites are both in Rose Run formation. We will then do the cost analysis based two scenarios to find at the best sequestration strategy.

The table shows the basic parameters studied for our site.

Table 6: Hydraulic Parameters of Rose Run

	Depth ^(a) (ft)	Thickness ^(a)	Permeability(mD)		Porosity(%)		Pressure Gradient (psia/ft)	Formation Fluid Temperature (1°F/100ft)	Bulk Density Representative
			Regional ^(b)	Site ^(c)	Regional ^(b)	Site ^(c)			
Rose Run Sandstone	2,500- 11,000	50-200	0.01-198	N/A	2-25	N/A	0.41- 0.46	1-1.2	2.2-2.8
Underlying Shawville, Clearfield, PA	7,550	75-150	N/A	13- 86	N/A	8- 14	0.43- 0.46	1	2.6

(a)---Approximation values based on nearby deep well.

(b)---Approximation values based on regional summary data

(c)---Approximation values based on nearby deep wells or gas fields

The Rose Run Sandstone has a low seismic hazard risk rating, and injection is unlikely to cause seismic activity unless injection occurs in a faulted interval.[4.4] No extensive faulting or fracturing is present in the study area.

Virtually all bedrock in the study area contains groundwater with TDS above the underground source of drinking water criteria of 10,000mg/L. For the Rose Run formation, even shallow bedrock wells produce water with TDS of well over 20,000mg/L. Consequently, the bedrock aquifers are not used as a source of drinking water in the area. TDS continues to increase with depth. With the depth ranging from 4180 ft to 4270 ft, TDS is always higher than 287,000mg/L and reaches to 313,000mg/L.

Figure 18 shows the locations of the Rose Run sandstone, a deep saline formation identified by the MRCSP as a potential carbon sequestration site [4.6]. As the figure shows, the plants all lie above or near to this formation, so suitable CO₂ injection sites presumably could be located very near to each of these plants.[4.6] The star indicates the location of the Colfax Field. The black triangle with the yellow boundary is the location of Shawville.

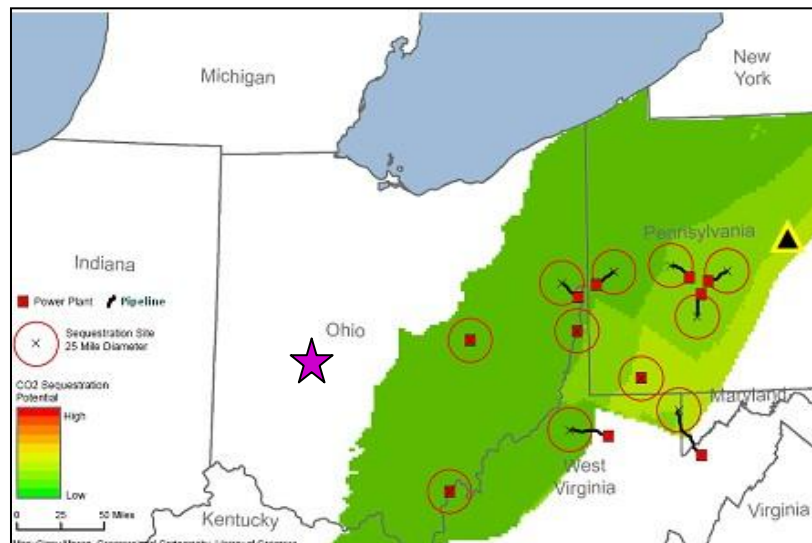

Figure 18: Major Power Plant and the Rose Run Formation

4.4 Reservoir Capacity Estimates

Estimates on reservoir capacity were calculated to provide some guidance on the amount of fluid that may be injected in the target formations. These capacities are an approximation involving many assumptions, and more detailed modeling is required to assess injection capacities. However, the methods are suitable for initial investigations. [4.5]

The estimates of the amount of CO₂ that may be injected into the target reservoirs at the area of interest were calculated using the equation proposed by van der Straten (1996) in the Joule II report: [4.5]

$$Q = V_p h_{st} \rho_{CO_2} \quad (2)$$

where,

$$V_p = V_b(\text{Net:Gross})\phi ,$$

V_b = bulk aquifer volume (km³),
 Net:Gross = percentage of porous, permeable rock,
 ϕ = formation porosity (%),
 h_{st} = storage efficiency (i.e., fraction of pore volume that can be filled with CO₂ [%]),
 ρ_{CO_2} = density of CO₂ (700 kg/m³) and,
 Q = storage capacity (Mt).

This equation is not a simple pore volume calculation, as it accounts for reservoir heterogeneity and inefficiencies in storage. It does assume that the injection formation is a homogeneous, “open” aquifer in which the entire volume is available for the injected CO₂. In the equation, storage capacity is a function of the bulk aquifer volume, the formation porosity, the percentage of the formation that is permeable rock, the storage efficiency of the formation, and the density of CO₂. Porosity and volume may be determined from nearby wells and isopach maps. Another way of calculating capacity has been shown in sequestration part. Density of CO₂ is 700 kg/m³. The ratio of net to gross permeable rock accounts for heterogeneity in the rock formation that may reduce its effective thickness. Similarly, storage efficiency accounts for the fraction of pore space available for injection. [4.5]

The ratio of permeable to impermeable rocks was assumed to be 75% for the base case. Low ratio was estimated at 50% and high ratio was estimated at 95%. Storage efficiency was assumed at 6% of available porosity. [4.5] The effective thickness underlying Shawville plant is 75-150 ft and its capacity would be 244Mt to 1024Mt CO₂. Figure 19 illustrates the effect of porosity and the ratio of permeable to impermeable rocks. As shown, porosity has the largest effect on reservoir capacity and is a key hydraulic parameter of the injection reservoir.

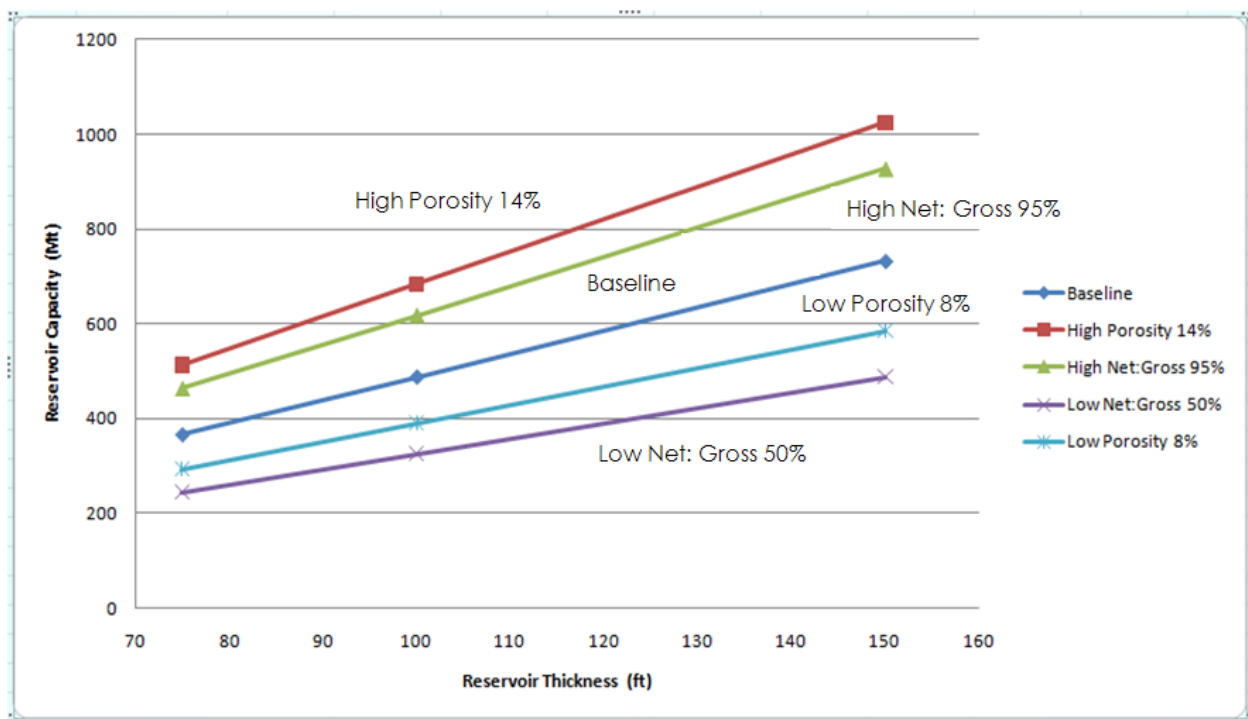

Figure 19: Estimated Injection Capacities underlying Shawville for a 25-mile radius injection site

4.5 Transportation

Carbon dioxide transportation via pipeline is an established technology with an established regulatory framework—with the MRCSP Region, dedicated CO₂ pipelines will be the primary means of transporting CO₂ from the point at which is captured to a suitable, long-term geologic storage site.

Carbon dioxide may be transmitted via pipeline as a low pressure gas or a supercritical fluid. Pipeline transmission as a supercritical fluid (compressed to 1073 – 3046 psi (7.4 - 21 MPa)) is considered the most reliable and cost effective method for transporting large amounts of CO₂. In the supercritical phase CO₂ has characteristics of both a liquid and gas, maintaining the compressibility of a gas while having some of the properties, such as density, of a liquid. Low viscosity is important for pipeline transport and the viscosity of CO₂ in the supercritical phase is the same as in the gas phase, which is 100 times lower than the liquid phase. Important from a cost standpoint, supercritical transport allows for substantially higher throughput through a given pipe cross-section than transport at lower gas pressures. [4.1]

The oldest long-distance CO₂ pipeline in the United States is the 140 mile Canyon Reef Carriers Pipeline (in Texas), which began service in 1972 for EOR in regional oil fields. Other large CO₂ pipelines constructed since then, mostly in the Western United States, have expanded the CO₂ pipeline network for EOR. These pipelines carry CO₂ from naturally occurring underground reservoirs, natural gas processing facilities, ammonia manufacturing plants, and a large coal gasification project to oil fields. Additional pipelines may carry CO₂ from other manmade sources to supply a range of industrial applications. Altogether, approximately 3,600 miles (5,800 km) of CO₂ pipeline operate today in the United States. Modern control technologies help to ensure pipeline integrity and safety—a pipeline section that is damaged can be quickly shut down, limiting the loss of CO₂. [4.7]

Other transportation modes generally refer to rail or truck transport that is in widespread use in the marketplace serving the food and beverage industries, specialty gas industry, and the oil and natural gas hydraulic fracturing business.

Pipeline transportation is believed as the most economical type for large quantity of CO₂ both for long and short distances.

4.5.1 Scenarios for CO₂ pipeline

Under a national CCS policy, a key question is how establish a CO₂ pipeline network at the lowest social and economic cost given the current locations of existing CO₂ source facilities and the locations of future sequestration sites. One recent analysis, for example concluded that 77% of the total annual CO₂ captured from the major North American sources could be stored in reservoirs directly underlying these sources, and that an additional 18% could be stored within 100 miles of additional sources [4.6]. Other analysts suggest that captured CO₂ may need to be sequestered, at least initially, in more centralized reservoirs to reduce potential risks associated with CO₂ leaks.[4.8] They suggest that, given current uncertainty about the suitability of various on-site geological formations for long-term CO₂ storage, certain specific types of formations (e.g., salt caverns) may be preferred as CO₂ repositories because they have adequate capacity and are most likely to retain sequestered CO₂ indefinitely. A third scenario envisions CO₂ sequestration, at least initially, at active oil fields where injection of CO₂, may be profitably employed for enhanced oil recovery (EOR). [4.9]

Whether CCS policies ultimately lead to centralized or decentralized storage configurations remains to be seen; however, pipeline requirements and storage configurations are closely related. A 2007 study at the Massachusetts Institute of Technology (MIT) concluded that ‘the majority of coal-fired power plants are situated in regions where there are high expectations of having CO₂ sequestration sites nearby.’[4.10]

For our project, we determine to choose the Colfax Field as the preferred sequestration site and stored underlying Shawville plant as well. In such cases, we prefer to construct our pipelines using the third and first scenarios to store the CO₂. The former demands the pipeline length around 250 miles and the latter within a 25 miles radius.

4.5.2 Special design consideration for CO₂ transmission system

Pipelines used for the transmission of CO₂ are very similar to those used for natural gas; however, CO₂ has different properties that must be accounted for in the design of pipelines and other CO₂ handling systems. Additionally, the CO₂ stream captured from point sources and meant for geologic storage would invariably contain some impurities. The gas mixture make-up is also an important consideration in the design of pipelines.

Some of the special considerations in the design of CO₂ pipelines are the following:

- In selecting the materials for use in CO₂ pipelines, the corrosion rate must be established for various temperatures and partial pressures of carbon dioxide. In relatively higher concentrations of carbonic acid, use of corrosion resistant materials provided with erosion protection has been recommended. These areas are typically located downstream of valves and in the vicinity of pumps. (Barrie 2003)
- Water, hydrocarbons and carbon dioxide may also combine to form hydrates that could plug the system. Minimizing the moisture content of the carbon dioxide stream is essential.
- Many lubricants, both synthetic and petroleum-based, harden in contact with CO₂ and become ineffective.
- Dry CO₂ has poor lubricating properties requiring special design features for pumps, compressors, etc.
- Carbon dioxide cools dramatically during decompression so pressure and temperature must be carefully controlled during depressurizing line segments and other routine maintenance activities.
- The CO₂ pipelines require some built-in surge capacities to minimize the potential for “water hammers” that can occur during flow changes.
- Supercritical CO₂ provides favorable conditions for the propagation of fractures requiring counter-measures such as installation of fracture arrestors on the pipeline.
- Carbon dioxide pipelines are typically buried except at the metering and compressor stations and under deep water. The seasonal temperature variations usually do not affect the fluid conditions in the pipeline. However, if the seasonal temperature variations are likely to impact the pipeline temperature, then those should be accounted for in design. [4.1]

Impurities impact compressibility of CO₂ and result in reduced flows through the pipeline. Specific to the CO₂ sources in the Midwestern region, the levels of impurities left after purification are unlikely to have much detrimental impact on pipeline capacity. [4.1] For our project, under certain capture techniques CO₂ in pipelines are assumed to be pure without impurities.

4.5.2 Pipeline Right of Way Consideration (ROW)

Siting a pipeline entails obtaining the proper regulatory permits and acquiring use of the land that the pipeline will occupy. Depending on the location of the proposed pipeline, environmental impact assessments, permitting, and acquisition of rights of way can take several years. After a pipeline route has been approved, land along the route must be acquired by an easement agreement, by purchase, or via eminent domain.

A pipeline right of way consists of a parcel of land under which a pipeline is buried. Rights of way are often about 50 feet (15 meters) wide. Right of way usually refers to access to a portion of a side of a street or an easement on private property granted to a utility. A right of way agreement between the pipeline company and a landowner is a form of easement (a limited perpetual interest in land that allows the pipeline owner to construct, operate, and maintain a pipeline across the land). An easement does not grant an unlimited entitlement to use the right of way. Pipeline companies are responsible for the right of way. The rights of the easement owner (Pipeline Company) are set out in the easement agreement.

Acquiring rights of way for CO₂ pipelines do not add much to the overall cost of a large CO₂ capture and storage project but acquiring these rights can take many years of negotiations with landowners, performing environmental impact studies, obtaining permits from various regulatory agencies and public service commissions. Within the MRCSP region, a promising approach to minimizing the cost and accelerating the acquisition of needed CO₂ pipeline rights of way could well center on making “shared use” of existing right of way corridors

4.6 CO₂ Transportation Cost

Carbon capture and storage requires CO₂ to be transported to a storage site. In this project, the Rose Run sandstone is chosen as the sequestration site with using two pipeline scenarios. We need to determine inlet/outlet pressure, temperature, design CO₂ mass flow and pipeline characteristics such as diameter and pipeline length. Combined with the economic parameters, such as the fixed charge factor, and operating and maintenance charges as input, we could finally get the value for pipeline transported CO₂ which is sequestered in deep saline aquifers.

It is generally recommended that a CO₂ pipeline operate at pressures greater than 1250 psia (8.6 MPa) where the sharp changes in compressibility of CO₂ can be avoided across a range of temperatures that may be encountered in the pipeline system [4.11]. Conversely, line-pipe with ASME-ANSI 900# flanges has a maximum allowable operating pressure of 2300 psia (15.3 MPa) at 38°C (100.4°F). [4.12]

4.6.1 Basic Assumption

At this stage, we consider one-to-one source-sink matching only, that is, we look at transportation CO₂ from one emission source or node to exactly one injection site.

Table 7: Case study input parameters and distributions for the transport models

<i>Parameters</i>	<i>Rep. Value</i>	<i>Distribution</i>
<i>Design CO₂ Mass Flow(Mt/year)</i>	3.4	Uniform
<i>Power Plant Capacity Factor(%)</i>	90%	Uniform
<i>Capital Recovery Factor</i>	0.15/yr	Constant
<i>Pipeline Transport Model Parameters</i>		
<i>Inlet Temperature(°F)</i>	53.6	Constant
<i>Inlet Pressure(pisa)/(Mpa)</i>	2200/15.2	Constant
<i>Outlet Pressure(psia)/(MPa)</i>	1500/10.3	Constant
<i>Total Pipeline Length(ft)</i>	132000/1320000	Uniform
<i>Pipeline Elevation Change(m)</i>	0	Constant

4.6.2 Calculations of Compressors & Pump Power Requirements

After CO₂ is separated from the flue gases of a power plant or energy complex (i.e., captured), it must be compressed from atmospheric pressure ($P_{initial} = 435\text{psia}$), at which point it exists as a gas, up to a pressure suitable for pipeline transport ($P_{final} = 2200\text{psia}$), at which point it is in either the liquid or 'dense phase' regions, depending on its temperature. Therefore, CO₂ undergoes a phase transition somewhere between these initial and final pressures. When CO₂ is in the gas phase, a compressor is required for compression, but when CO₂ is in the liquid/dense phase, a pump can be used to boost the pressure. It can be assumed that the 'cut-off' pressure ($P_{cut-off}$) for switching from a compressor to a pump is the critical pressure of CO₂, which is 1070 psia. Hence, a compressor will be used from 435psia to 1070 psia, and then a pump will be used from 1070 psia to 2200psia.

$$P_{initial} = 435 \text{ psia}$$

$$P_{final} = 2200 \text{ psia}$$

$$P_{cut-off} = 1070 \text{ psia}$$

In this project, two scenarios will lead to different values with respect to compression power requirement. An important technical consideration in the design of pipelines for transport of supercritical CO₂ is that the CO₂ remains above critical pressure. This can be achieved by means of

recompression of the CO₂ at certain points along the length of the pipeline. Recompression is often needed for pipelines over 475200 ft in length. For the longer distance scenario, we add two more recompression systems since the pipeline length is 1320000 ft. The detailed formula is showed in Appendix A. Table 8 shows the results for two scenarios.

Table 8: Calculated power requirements for two storage site

<i>Scenario</i>	<i>One (Underlying Plant Storage)</i>	<i>Two (For EOG)</i>
<i>Compression Power Requirement</i>	3.24E+03 (kW)	9.73E+03(kW)

4.6.3 Capital, O&M, and Levelized Costs of CO₂ Compression and Pumping

The following table and figures show our cost estimation of the capital cost due to power required for two scenarios in our project.

Table 9: Cost of Capital, O&M, and Levelized Costs of CO₂ Compression and Pumping

<i>Scenario</i>	<i>One (Underlying Storage)</i>	<i>Two (For EOG)</i>
<i>Capital Cost of Compressor(s)[\$]</i>	8.39E+06 /compressor	2.52E+07/3 compressors
<i>Capital Cost of Pump(s) [\$]</i>	1.88E+06	1.88E+06
<i>Capital Recovery Factor</i>	0.15/yr	0.15/yr
<i>Annualized Capital Cost of Compressor(s) and Pump(s) [\$ /yr]</i>	1.54E+06	4.06E+06
<i>Levelized Capital Cost [\$ /tone CO₂]</i>	0.5034	1.3261

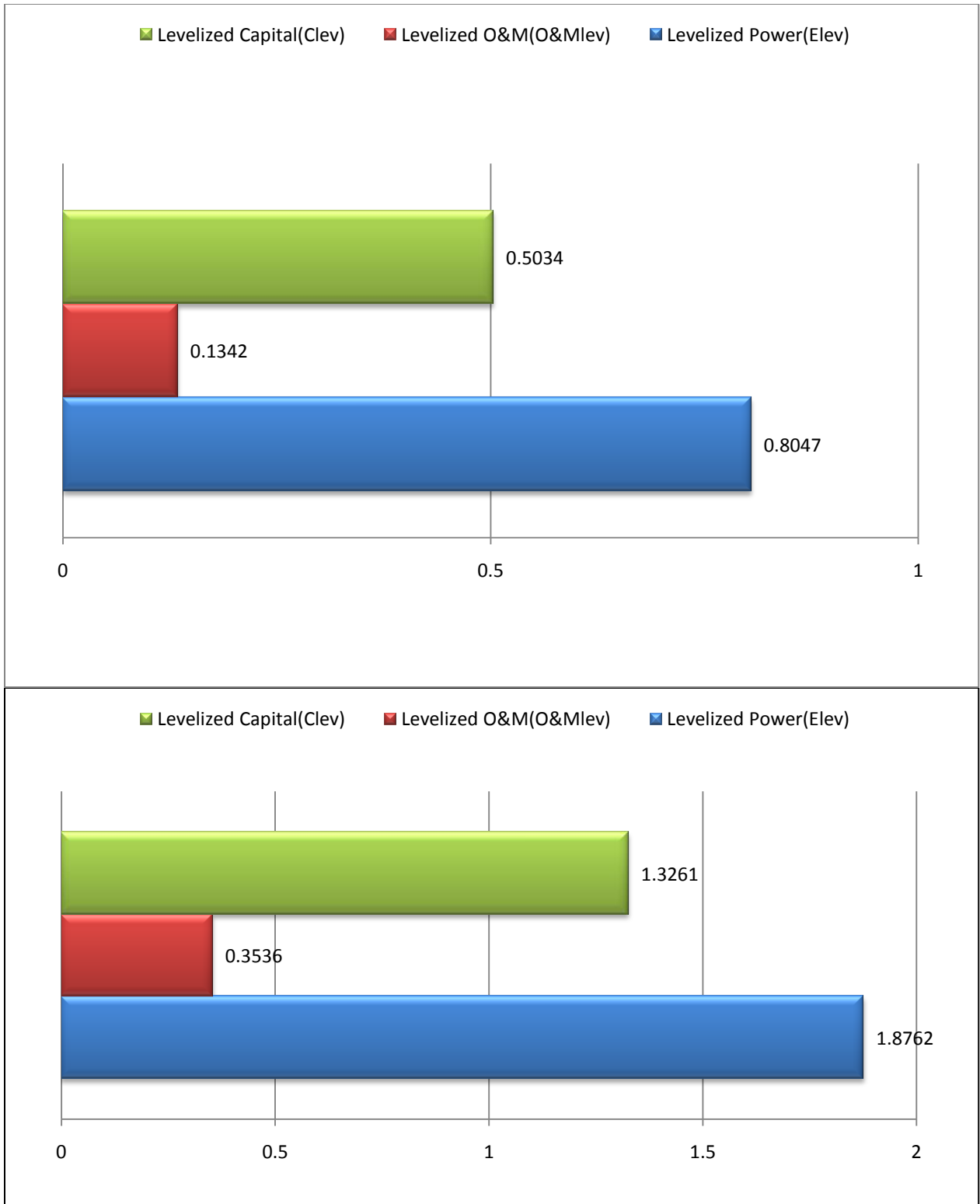

Figure 20: Visualizing the Levelized Capital, O&M and Power cost [\$/ton CO₂]

From Figure 20 it is seen that electricity power cost outweighs the other two costs. A key parameter impacting the electricity power cost is the price. In this project, the price of electricity is \$0.065/kWh.

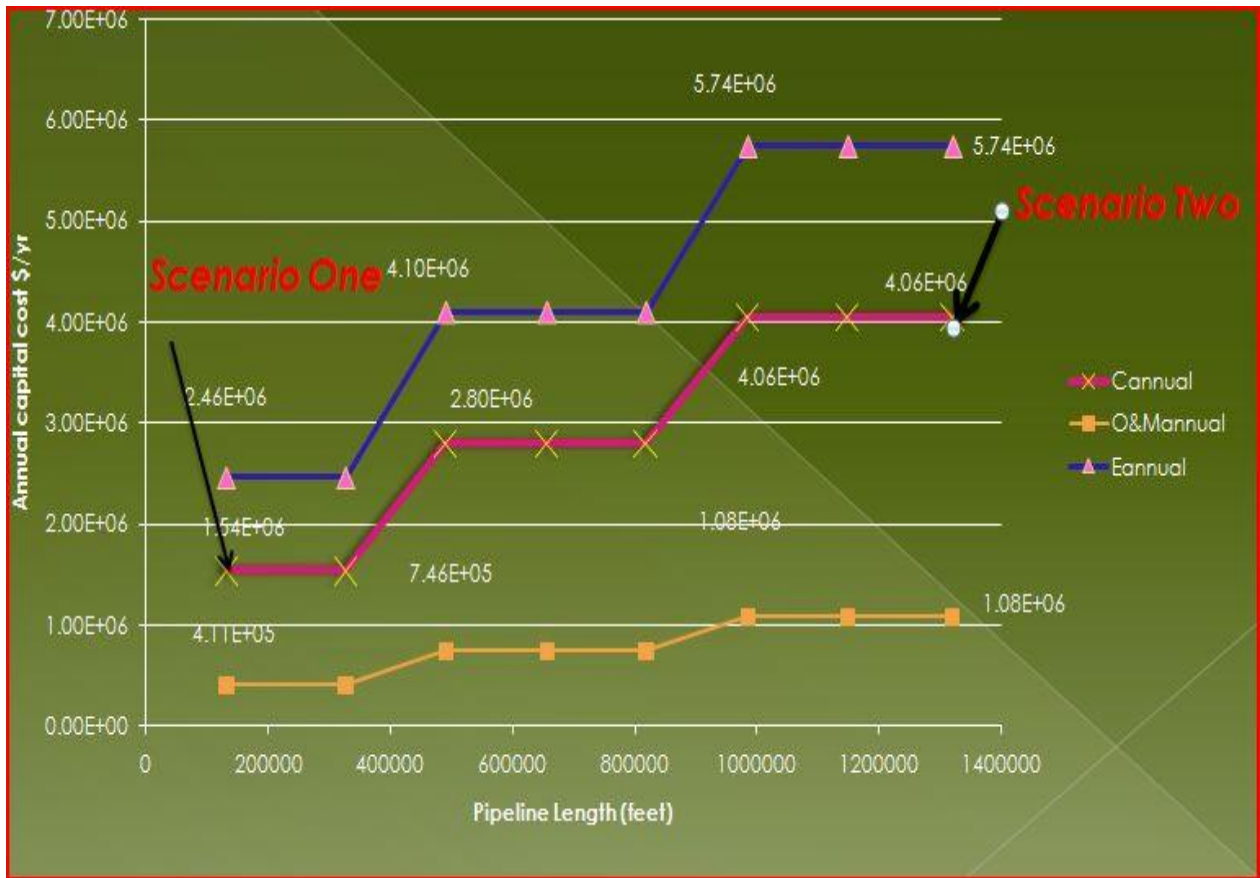

Figure 21: Annualized costs as a function of Pipeline Length

This figure shows the annual cost of capital cost of compressors and pumps; operation and maintenance and electric power vs. different pipeline length under the same CO₂ emission per year and same capital factor.

As the result, we determine the total annual cost with respect to compressors and pumps power requirements by adding the annualized capital cost of compressors and pumps, annual O&M cost and total annual electric power costs of compressor and pumps up. For the first strategy we achieve the value of 4.41E+06 \$/yr, while another is of 1.09E+07 \$/yr. And the levelized values are 1.4423 \$/tonneCO₂ and 3.5559 \$/tonneCO₂ respectively.

4.6.4 Determine the diameter of pipeline

It is assumed that the transportation distance for the Colfax Field is 250 miles away from the Shawville plant and underlying storage radius is 25 miles. It's a 572MW coal plant with CO₂ emission of 3.4 million tons/year and the capital factor is 0.9. The diameter needs to be found using some equations and assume supercritical CO₂ as an incompressible fluid and the pipeline flow and pumping processes as isothermal.

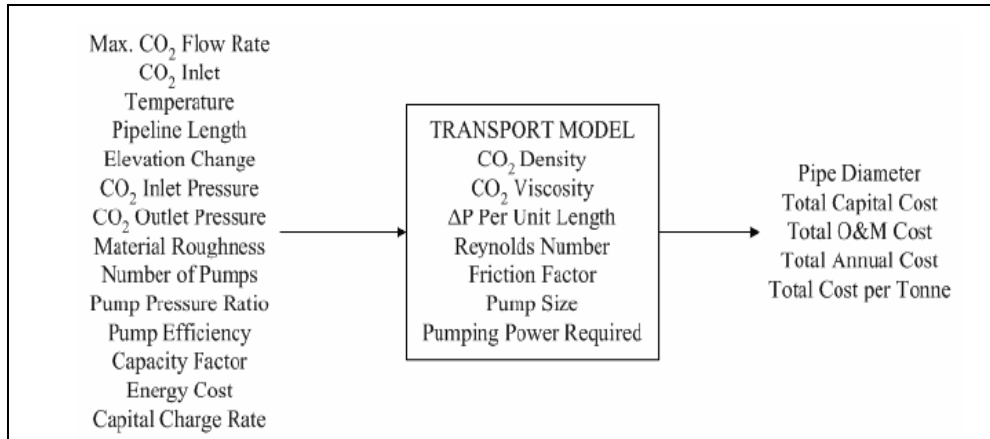

Figure 22: The boundaries, inputs, and output of the pipeline model

Since the calculation of pipeline diameter is an iterative process, one must first guess a value for diameter (D). A reasonable first approximation is $D=10$ inches. An estimation of the density (ρ) and viscosity (μ) of CO_2 in the pipeline (approximated at T and P_{inlet}) is also required. We choose to use [4.13] to get approximation values using actual values from Kinder Morgan. Finally, the solutions are 10 inches for the pipeline length of 25 miles and 16 inches for the pipeline length of 250 miles.

4.6.5 Capital, O&M, Levelized Costs for CO_2 Transportation

Transportation costs comprise the capital cost of pipeline construction and annual pipeline operation and maintenance (O&M) costs. The pipeline O&M cost is held at \$5,000/mile per year, independent of pipeline diameter. [4.14]

We compare with three engineering-economic models of pipeline transportation of CO_2 which are Ogden Model, MIT Model correlation and the CMU Model. Finally we confirm to use CMU correlation which takes into account regional differences in pipeline construction costs by using regional variables called 'Region weights'. For the Midwest, the region weight is 1.516.

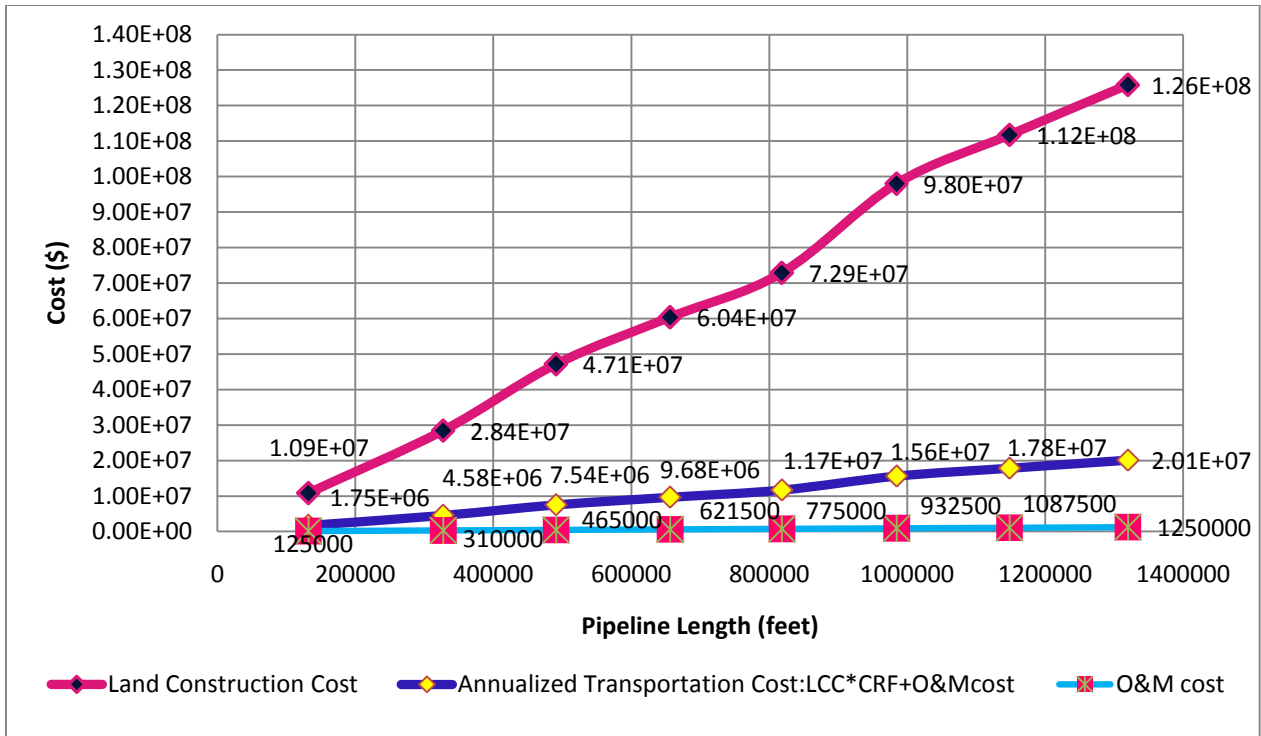

Figure 23: Transportation Cost as a Function of CO₂ Pipeline Length

The Land Construction Cost (LCC) of CMU correlation differs in that it departs from the linearity restriction in the MIT correlation and allows a double-log (nonlinear) relationship between pipeline land construction cost and pipeline diameter and length.

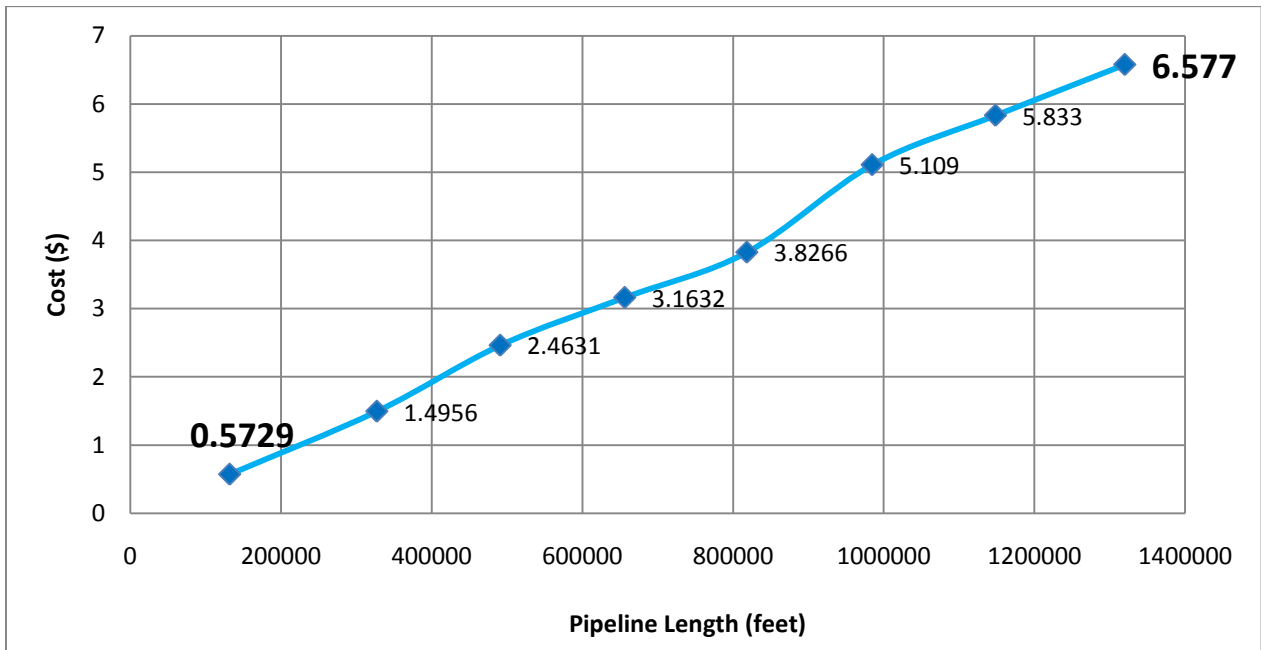

Figure 24: Levelized Transportation Cost as a Function of CO₂ Pipeline Length

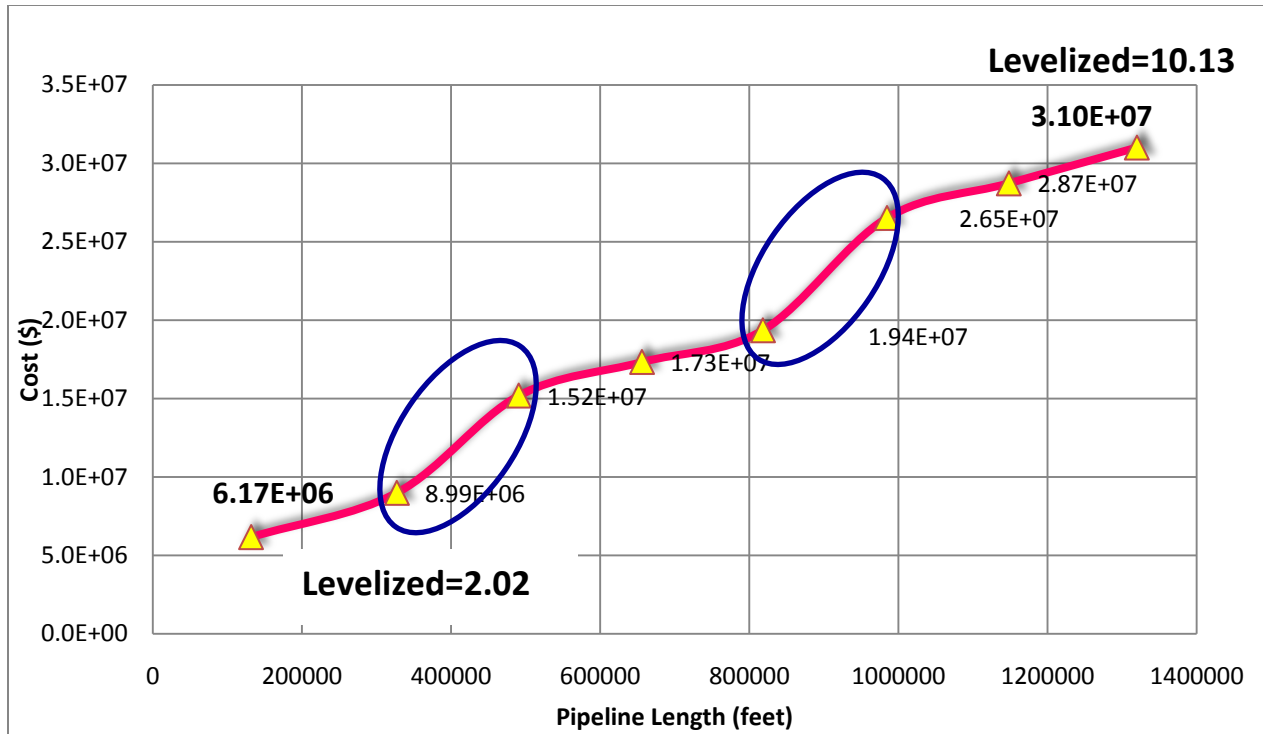

Figure 25: Total Annual Cost as a Function of CO₂ Pipeline Length

The final step is to combine the power consumption and transportation annualized cost together as a function of pipeline length. In the Figure 25, the first sharper slope in a blue cycle is because of the recompression and increase of diameter of pipeline. This could also explain the second sharper slope.

Table 10: Conclusion of Transportation Cost

Scenario	One (Underlying Plant Storage)	Two (For EOG)
Combined Annual Total Cost (Power Consumption+Transportation)[\$/yr]	6.17E+06	2.02
Levelized [\$ /tone CO ₂]	3.10E+07	10.13

4.7 Future work

At this stage, we only consider the source-sink matching while future work focuses on many-to-many sources-to-sinks matching. Carbon dioxide may be transported directly to a storage site, or, where a large network of pipelines exists, it may be transported to a pipeline hub to join CO₂ collected from other sources and subsequently piped to a storage site. And then we may establish economic model of transportation and storage on this basis.

The cost of CO₂ transportation is a function of pipeline length (among other factors), which in turn is determined by the location of sequestration sites relative to CO₂ sources. Some analysts believe that CO₂ pipeline costs will be moderated in the future because generating companies will construct new

power plants geographically near sequestration sites. Recent network cost models suggest otherwise. On a mile-for-mile basis, these models show that electricity transmission costs (including capital, operations, maintenance, and electric line losses) generally outweigh CO₂ pipeline costs in new construction. Accordingly, the least costly site for a new power plant tends to be nearer the electricity consumers (cities) rather than nearer the sequestration sites if the two are geographically separated.[4.6]

Any company seeking to construct a CO₂ pipeline must secure siting approval from the relevant regulatory authorities and must subsequently secure rights of way from landowners. There is no federal authority over CO₂ pipeline siting, so it is regulated to varying degrees by the states (as is the case for oil pipelines). The state by- state siting approval process for CO₂ pipelines may be complex and protracted, and may face public opposition, especially in populated or environmentally sensitive areas. Questions arise as to the right of easement holders to install CO₂ pipelines, compensation for use of such easements, and whether existing easements can be sold or leased to CO₂ pipeline companies. Although these siting issues may arise for any CO₂ pipeline, they become more challenging as pipeline systems become larger and more interconnected, and cross state lines. If a widespread, interstate CO₂ pipeline network is required to support CCS, the ability to site these pipelines may become an issue requiring new federal initiatives.[4.6]

Furthermore, capacity limitations at favorably located sequestration sites (like the Rose Run formation) may lead to competition among large CO₂ source facilities seeking to secure the best local sequestration sites before others do. Carbon dioxide transportation costs could raise electricity prices even higher above the national average which may become an issue for Congress. [4.6]

Chapter 5: Sequestration of CO₂

5.1 Introduction

Carbon sequestration is a technique for the long-term storage of carbon dioxide. It is a technique of reducing the carbon content in the environment, thereby mitigating the global warming. Carbon dioxide is generated in the atmosphere either by natural sources or by anthropogenic sources.

Carbon dioxide may be captured as a pure by-product in processes related to petroleum refining or from flue gases from power generation. Carbon dioxide can be sequestered in subsurface saline aquifers, reservoirs, ocean water, aging oil fields, or other carbon sinks. After capturing CO₂ from its generation source it is transported by suitable transportation means to the sequestration site, & then is sequestered.

A number of sequestration projects are running throughout the world. United States has a great potential in sequestering CO₂.

Out of many possible sites for sequestration in U.S., Rose Run formation is a very good candidate for sequestering CO₂. This projects concerns the sequestration of carbon dioxide generated by a coal fired

power plant(Shawville, PA, 572MW capacity) in the Rose Run formation with the option of enhanced oil recovery from the depleted oil reservoir(Coal Fex Field).

5.2 Geological Description of Rose Run Formation

The Rose Run formation is in southern Pennsylvania which extends beneath eastern Ohio, New York & Kentucky in the Appalachian Basin of the Eastern United States. The Rose Run Formation is a complex unit that is composed of a mixture of both carbonate and siliciclastic lithologies and is heterogeneous at multiple scales. The stratigraphy study of Rose Run formation shows that it composed of interbedding of 7 major rock types:

Dolomudstone; ooid grainstone; stromatolite boundstone; wavy-bedded shale, sandstone, and carbonate; shale; sandy carbonate; and quartz Sandstone. Clay, quartz sand, and carbonate grains are locally well mixed within single beds. [5.1] Also, quartz sandstone is locally cemented by carbonate and carbonate ooids are replaced by quartz so that the beds are compositionally and texturally heterogeneous and carbonate and siliciclastic lithologies are mixed at multiple scales[5.1]. Rose Run & other sandstone formations nearby are rich in glauconite, which is an important alternative of Ca-feldspar as a source of calcium for mineral trapping of CO₂.

After having a look at the geologic properties of Rose Run formation, we can see that it's a very good candidate of sequestering CO₂. The Rose Run Sandstone has the potential to store CO₂ over millennia as a negatively buoyant aqueous solution and, ultimately, as immobile carbonate minerals. Figure 26 shows a measured section of core from sandstone core [6.3].

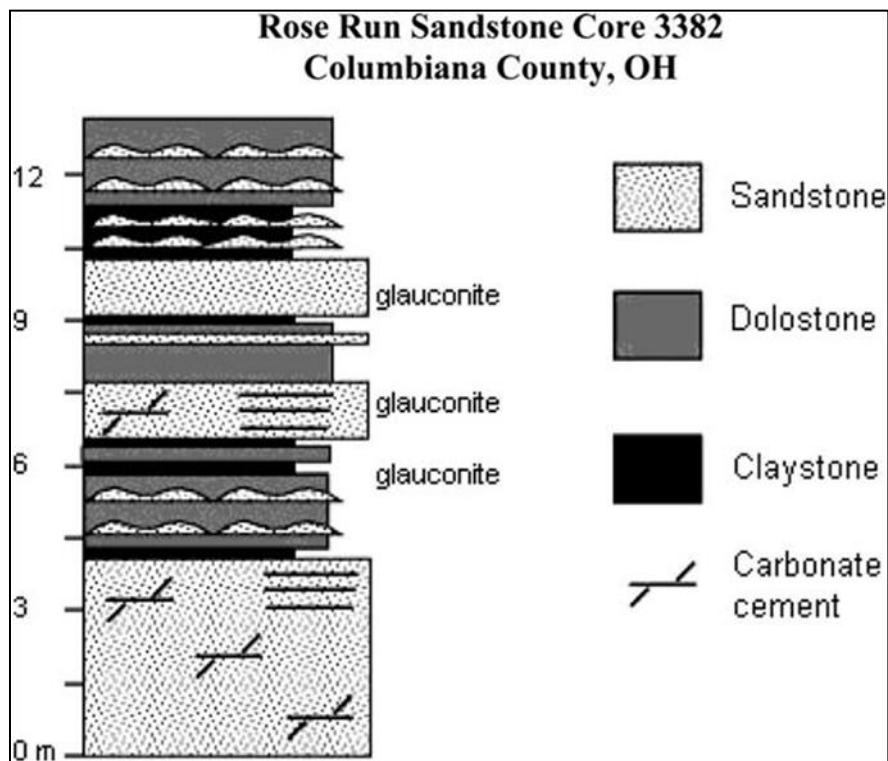

Figure 26: Measured section of core through part of the Rose Run Sandstone

5.3 Suitability of Rose Run Formation For Reliable Carbon Storage in Oil/Gas Reservoirs Within EOR

CO₂ sequestration in the depleted oil/gas reservoirs is the long term solution of mitigating CO₂ concentration in the environment and make thereby reducing global warming. Oil/gas reservoirs have large capacity to store CO₂ for a very long period of times. As recovery in the gas reservoirs(about 65% of OGIP) is more than that in oil reservoirs(35% of OOIP), so gas reservoirs have larger capacity for storing CO₂ than oil reservoirs. But we need to study the phase behavior of CO₂, pure CH₄ and their mixtures, in order to study the sequestration in gas reservoirs.

Suitability of any formation for CO₂ sequestration depends mainly on the 3 factors: capacity, injectivity, containment. Capacity means how much carbon dioxide can be stored in the formation. Total capacity of O & G reservoirs is found to be 675-900*10⁹metric tons of CO₂ [5.3]. Injectivity means how fast CO₂ can be pumped in the formation. In order to economize the sequestration process we need to maximize injectivity per well. Rose Run formation has enough permeability required for injectivity. Containment is how long and how effectively CO₂ can be stored in the formation, as Rose Run formation is rich in glauconite & other Ca & Mg minerals, so it can effectively trap CO₂ through mineral trapping for millions of years.[5.3]

5.4 Physical Properties of CO₂

At normal standard conditions CO₂ is a gas with density of 1.872kg/m³. Critical point for CO₂ is T_c=31.1°C and P_c=7.38 MPa(1070 psia). For temperature & pressure above the critical point, CO₂ is a supercritical fluid, means it will have its density characteristics like that of liquids & volume like gas. Both temperature & pressure increase with depth, but have opposite effect on CO₂ density. As temperature increases, density of CO₂ decrease & it increases with increases in pressure. In subsurface pressure changes about 10MPa/Km, and temperature changes by 25°C. So when injected at normal conditions CO₂ reaches it's critical point at about 700m. Figure 27 shows the phase behavior of CO₂.

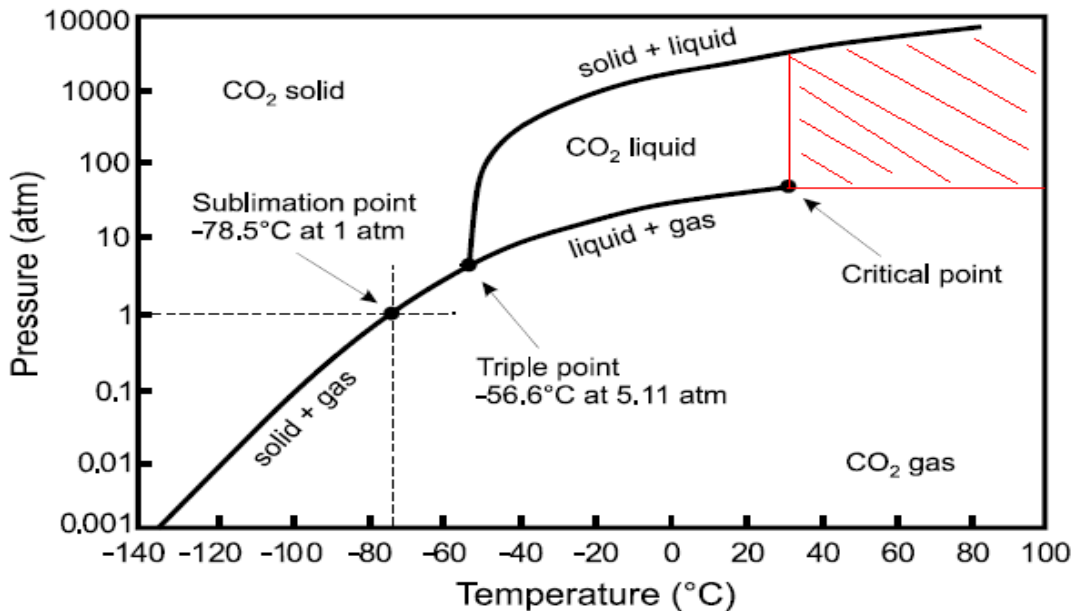

Figure 27: Phase behavior of CO₂

The critical temperature and pressure for CO₂ are 31°C (88°F) and 7.38 MPA (1070 psia). Whereas, reservoir pressure and temperatures are encountered between a range of 500-3000 psia and 68– 174° F, so from the phase behavior of CO₂ it can be seen that CO₂ in most of the reservoir will fall in the critical region.

Also reservoir pressure and temperature are a function of depth. As has been mentioned before, the pressure gradient in Rose Run is 0.41-0.46psia/ft. and temperature gradient is around 1-1.2°F/ft.

So we see that at a depth of around 700m (2297 ft), CO₂ will reach at its critical phase.

$$P= 14.7+0.43*\text{depth} \quad (3)$$

$$T=61+1.1* \text{depth} \quad (4)$$

So it is better to store CO₂ in very deep reservoirs where CO₂ meets the supercritical stage and has high molar density.

5.5 CO₂ Migration Behavior with the Pore Fluid

When CO₂ is injected into geological formation, it displaces the pore fluid there. Displacement can be miscible or immiscible depending on the chemical composition of CO₂, temperature and pressure. CO₂ and water are immiscible. Oil and CO₂ may or may not be miscible, depending on the composition of the oil and the formation pressure. CO₂ and natural gas are miscible. When the fluids are miscible, the CO₂ eventually displaces nearly the entire original fluid. Injection of an immiscible fluid bypasses some fraction of the pore space, trapping some of the original fluid. When EOR is performed using CO₂, miscible displacement is preferred, though oil can also be recovered by immiscible displacement.

5.6 Trapping Mechanism

Carbon dioxide is trapped in the formation by mainly four trapping mechanisms.

5.6.1 Hydrodynamic trapping

This is the temporary mechanism of CO₂ trapping, but is necessary for starting other mechanisms. Once injected, the supercritical CO₂ can be more buoyant than other liquids that might be present in the pore space. The CO₂ will therefore percolate up through the porous rocks until it reaches the top of the formation where it meets (and is trapped by) an impermeable layer of cap-rock. With a man-made CO₂ storage site, the wells that were drilled for injection through the cap-rock would be sealed with solid physical plugs made of steel and cement, a method which is already used extensively by the natural gas storage industry.

5.6.2 CO₂ residual trapping

This phase of trapping happens very quickly as the porous rock acts like a tight, rigid sponge. As the supercritical CO₂ is injected into the formation it displaces fluid as it moves through the porous rock. As the CO₂ continues to move, fluid again replaces it, but some of the CO₂ will be left behind as disconnected - or residual - droplets in the pore spaces which are immobile. This is often how the oil was held for millions of years.

5.6.3 Solubility trapping

Carbon dioxide dissolves in other fluids in its gaseous and supercritical state. This phase in the trapping process involves the CO₂ dissolving into the salt water (or brine) already present in the porous rock. Just as a bottle of fizzy water is actually slightly heavier than the same bottle filled with still water, so this salt water containing CO₂ is denser than the surrounding fluids and so will sink to the bottom of the rock formation over time, trapping the CO₂ even more securely.

5.6.4 Mineral trapping

The final phase of trapping results from the fact that when CO₂ dissolves in water it forms a weak carbonic acid. Over a long time, however, this weak acid can react with the minerals in the surrounding rock to form solid carbonate minerals. This process, when it takes place naturally, is very slow, but it effectively binds CO₂ to the rock.

Some of the basic Reactions involved in mineral trapping are as follows;

The most basic chemical reactions that lead to solubility trapping and mineral carbonation are [5.4]

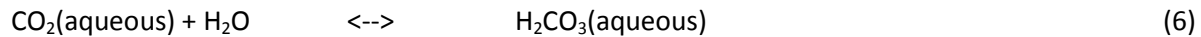
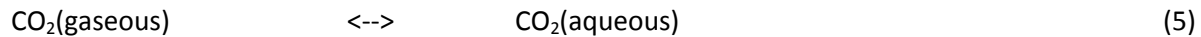

Solubility trapping

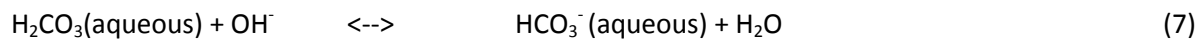

Ionic trapping

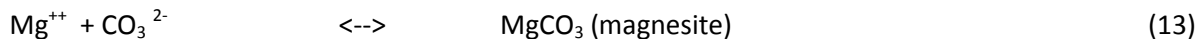
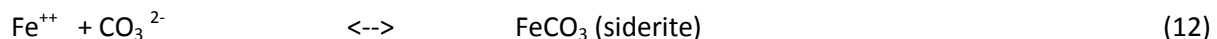
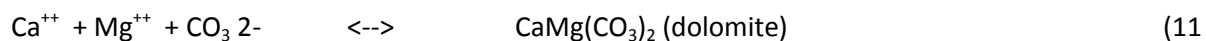
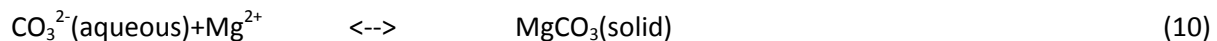
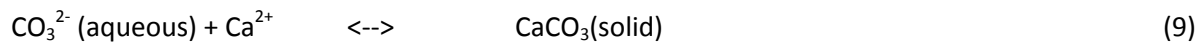
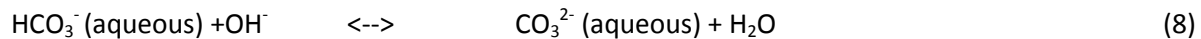

Mineral trapping

As we can see CO₂ forms carbonic acid, so pH decreases with the addition of CO₂. The pH of the system affects the reaction rate and species precipitated. In a closed system dissolved carbon dioxide, CO₂(aq) and H₂CO₃ (carbonic acid) dominate at low pH, HCO₃⁻ (bicarbonate) dominates at mid pH, and CO₃²⁻ (carbonate) concentration increases at high pH. The solubility of carbonate also increases as the pH decreases. Thus, aqueous-phase equilibrium with CO₂(g) promotes carbonate precipitation under basic conditions, while acidic conditions favor carbonate dissolution. Therefore, to favor the precipitation of

mineral carbonates, the pH must be basic. Thus pH is an important factor which controls the mineral trapping (temp. and pressure has minimal effects on mineralization).

Basic environments at high pH condition, pH= 11, provide an abundant supply of OH⁻(aq), that leads to the formation of HCO₃⁻ and CO₃²⁻ and finally the formation of CaCO₃. The formation of calcite is expected to slow, once the OH⁻(aq) is consumed. So it is concluded that in order to fasten the process we need to increase the Ph of the system [5.4].

5.7 Forced Mineral Trapping

Forced mineral trapping is the technique in which pH of the system is increased by introducing alkalinity in the system. In the U.S., hundreds of millions of tons of construction/demolition (C&D) waste are generated per year (LUND, 1993). Over 60% of the mass content of typical demolition debris is concrete (LUND, 1993). Lack of established markets and recycling facilities results in much of this material being land filled in many parts of the country. Because the principal constituent in concrete is portlandite [Ca(OH)₂], C&D waste represents a potentially large source of alkalinity. Rain or irrigation water reacting with crushed concrete would provide a source of Ca(OH)₂ for use in conditioning shallow terrestrial or deep geologic reservoir pore water to enhance formation of carbonate minerals. So forced mineral trapping can be applied w/o even adding ay additional cost to sequestration.

Figure 28 below shows the contribution of different trapping mechanisms involved in sequestration & also the time scale for each mechanism after injection of CO₂ in case of natural trapping mechanism.[5.5] Figure 29 shows contribution of trapping mechanisms after implication of forced mineral trapping. It can be seen that in forced mineral trapping, mineral trapping contributes more than 50% of trapping, and also time, when mineral trapping starts, is decreased 20 times as compared to natural mineral trapping. So forced mineral trapping is very promising technique for sequestering carbon dioxide in Rose Run formation for long time.

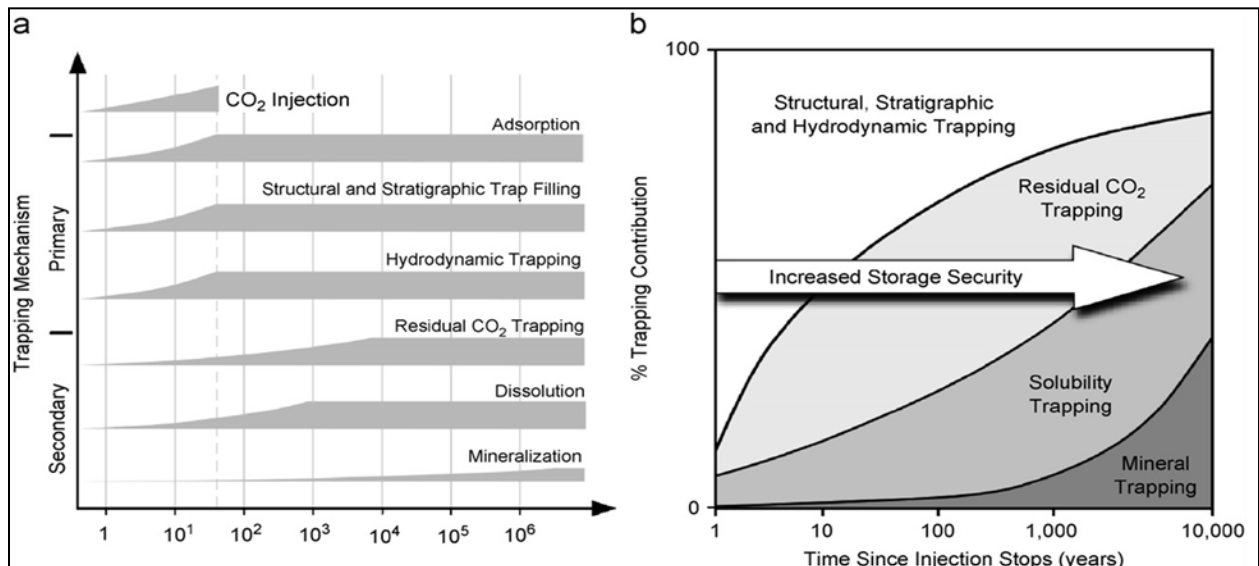
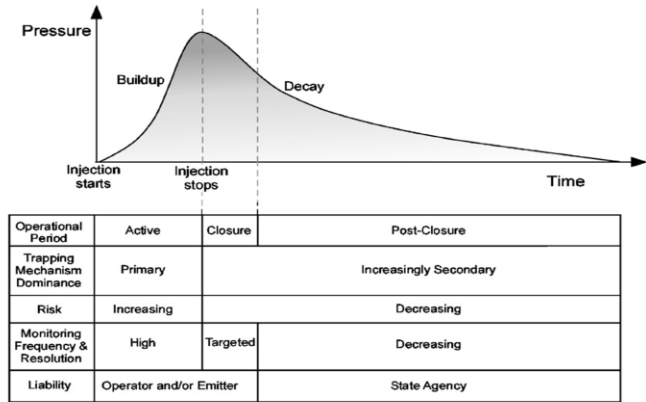
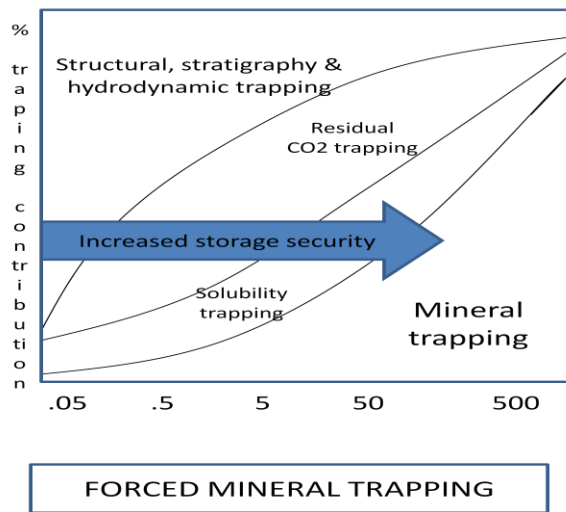

Figure 28: Differences between various CO₂ Trapping mechanisms in geological media: (a) operating timeframe, and (b) contribution to storage security



Relation between pressure behavior and operational phases, dominance of CO₂ trapping mechanisms, monitoring frequency and resolution, and liability at a CO₂ storage site.

Figure 29: Mineral Trapping behavior

The figure on the right hand side of figure 29 shows the relationship between pressure behavior & operational phases. We can see that after CO₂ injection is stopped, & secondary trapping comes into picture, risks associated with sequestration become less. Also, need for monitoring decreases after starting of secondary mechanisms.

Some facts and assumptions regarding forced mineral trapping include that most of the CO₂ will remain in free phase, it's only after hundreds of years and mineral trapping dominates all other trapping mechanisms. Also, porosity & permeability will be changed once the injection starts, and it will affect the capacity of formation. In case of sequestration within EOR, Ca(OH)₂ will be injected after completion of enhanced oil recovery.

5.8 Technical Aspects and Challenges in Sequestration

Most important challenge in CO₂ sequestration is to avoid the leakage. When CO₂ is injected in deep formations, because of buoyant forces, it tries to escape the reservoir. Also it is lighter than water(contained in the reservoir) , so it has tendency to escape through the migration paths which are made by Hydrocarbons. CO₂ is non wetting phase in the reservoir, so it experience large capillary forces. These forces help CO₂ sequestering in the reservoir, as they are much larger than the buoyant forces. Good possibility of leakage is there, if buoyant forces overcome these capillary forces somehow.

Sealing capacity of the cap rock for a hydrocarbon-water system is sufficient to prevent the injected CO₂ from leaking. Sealing capacity is a measure of the breakthrough pressure. Capillary pressure determines the breakthrough pressure of the cap rock. Also capillary pressure of the interconnected pore channel depends upon the interfacial tension as shown below:

$$P_c = (2\sigma/R_p) * \cos \theta \tag{14}$$

- Where
- P_c= capillary pressure
 - σ=interfacial tension between the non-wetting (gas or oil) & the wetting phase(water)
 - R_p=radius of pore throat
 - Θ= contact angle

So interfacial tension plays important role in avoiding the leakage of CO₂ back in the atmosphere, also the breakthrough pressure of the cap rock should also be calculated.

5.9 Modeling Of Sequestration of CO₂ in Rose Run

As has been discussed in the capture section, the amount of CO₂ from the plant is around 3.4Mton/year. We are capturing near about 90% of total emission (3.06Mton/year). It can be converted into field units as follows:

$$1\text{lbs of CO}_2 = 1/44 \text{ lb mol of CO}_2$$

$$1 \text{ lb mol of CO}_2 = 379.1\text{SCF OF CO}_2$$

$$3.06 \text{ Million ton} = 3.06 * 10^9 \text{ Kg} = 6.74 * 10^9 \text{ lbs}$$

$$\text{So } 3.06 \text{ million ton of CO}_2 = 5.8 * 10^{10} \text{ SCF of CO}_2$$

So $5.8 * 10^{10}$ SCF of CO₂ amount of CO₂ is needed to sequester per year.

A model has been established using GEM for finding out how many no. of wells are required to inject all of CO₂ in the formation. Reservoir has been discretized in 11*11 square blocks, and dimension of each side of block is 2000ft. Properties of the formation which are used while making the model are as summarized in the table 11 below.

Table 11: Ground rock properties of formation

	Depth (ft ³)	Thickness (ft)	Permeability (mD)		Porosity (%)		Pressure gradient	Formation Fluid Temperature (1F/100ft)
			Regional	Site	Regional	Site		
Rose Run sandstone	2500-11,000	50-200	0.01-198	N/A	2-2.5	N/A	0.41-0.46	1-1.2
Underlying Shawville (PA)	7550	75-150	N/A	13-86	N/A	8-14	0.43-0.46	1

Properties of the Rose Run sandstone (25miles away from the Shawville power plant location) where we are actually sequestering the CO₂ are assumed on the basis of above data and are as in the table 12 below.

Table 12: Rose Run assumed rock properties

	Depth(ft)	Thickness (ft/layer)	Permeability (mD)	Porosity (%)	Block Dimensions(ft2)	Initial Reservoir pressure (psia)
Rose Run sandstone	7000	30	15	2.5	2000*2000	3000

We are considering a time span of 30 years. That means 30 years of CO₂ emission from Shawville power plant will be sequestered. Reservoir has been assumed to be homogeneous with a permeability value of 15mD in each direction. Also whole reservoir has been considered to be consisting of one layer. Wells location has been considered as symmetric to each other, so injection rate in every well is same (all wells are identical). Figure 30 below shows the location of wells in the formation. A total of 5 wells have been used. All wells are injection wells. Figure 31 shows the cumulative injection and the rate of CO₂ injection.

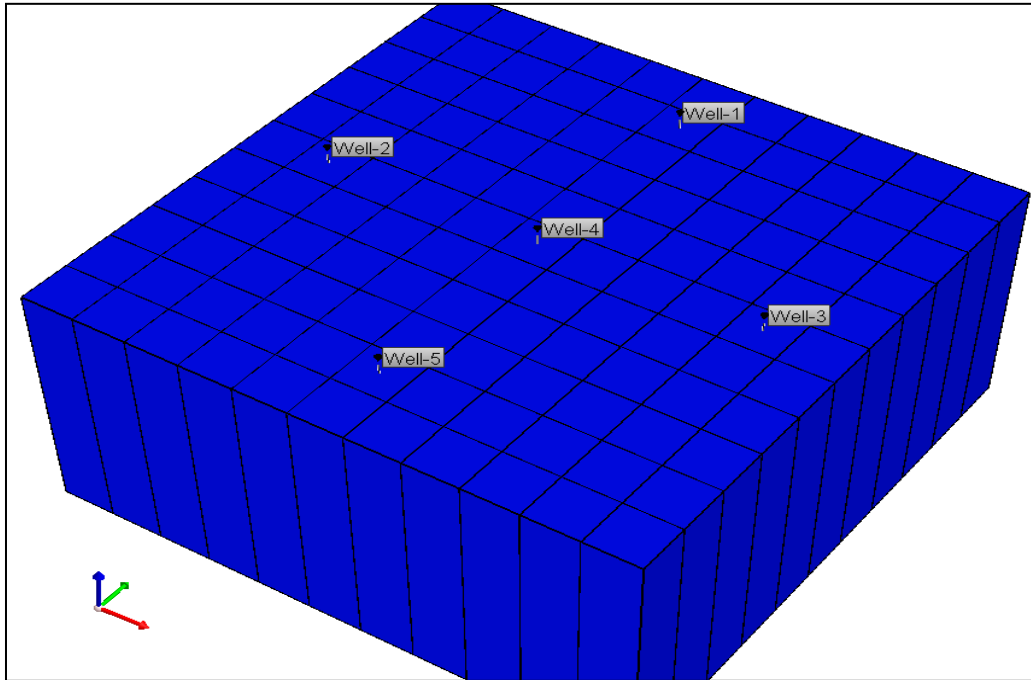

Figure 30: 3-D representation of the field

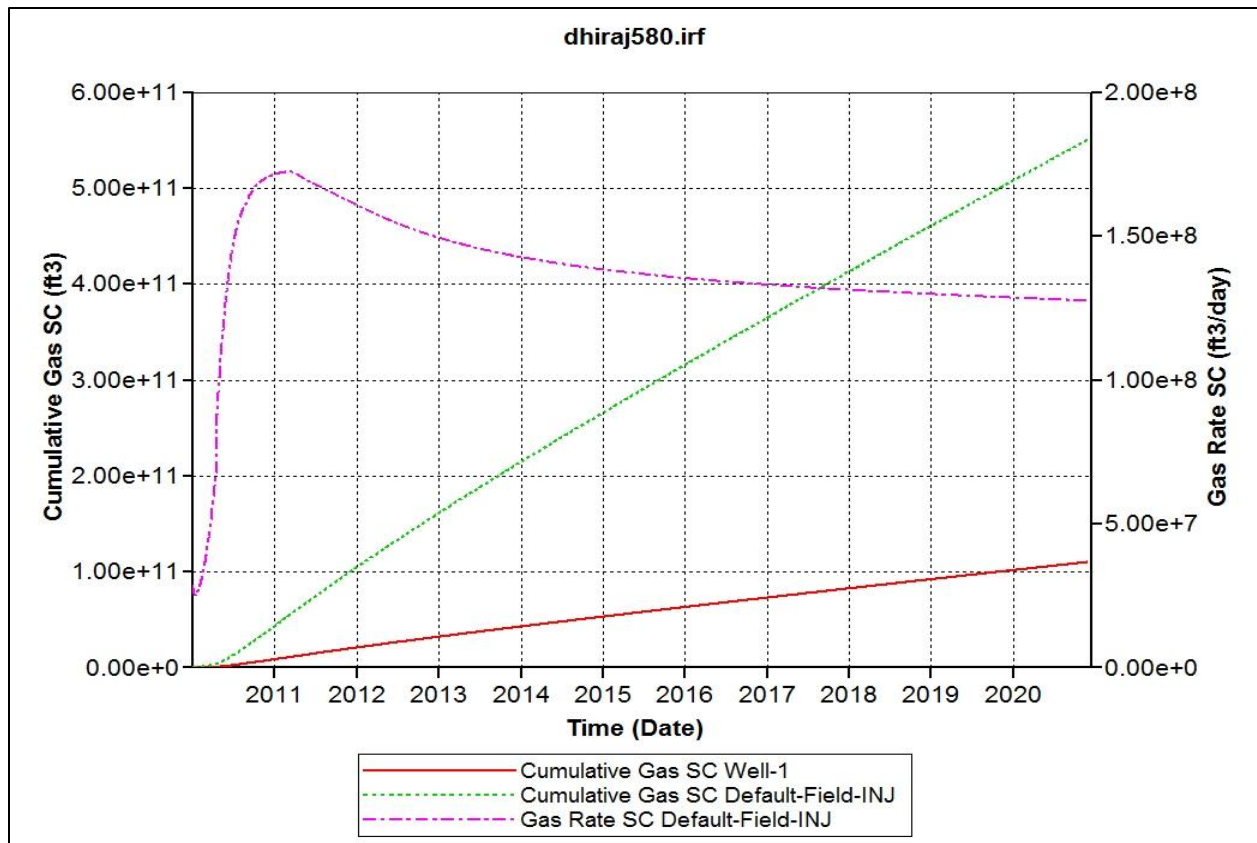

Figure 31: Cumulative and rate of CO₂ injection

5.10 Economic Analysis for Sequestration

Rose Run formation has lots of depleted oil and gas reservoirs, thereby in past a number of wells were drilled in the formation. So we are not drilling any new well, but we will use the wells already drilled for injecting the CO₂. Wells which are already drilled there are reworked so to make them suitable for injecting CO₂.

As we are not producing anything (we don't have any production well) in this model so the only costs which are associated in the project are cost of capturing CO₂, cost of transportation cost of reworking on wells, O & M costs and costs related to monitoring. Only costs which are considered in the economic analysis of CCS are as in table 13.[6.6]

Table 13: Cost of reworking wells

VARIOUS COSTS	PER WELL PER YEAR (\$)	TOTAL(MM\$)
reworking on existing wells	181968.75(constant for 1 well)	-0.9098
operating & maintenance costs	111863.75/ well/year	-5.593
total		-6.5028

Costs of capture, transportation, and monitoring are considered in the project conclusions cost analysis.

The project shows that in simple cost analysis which will be compared for same conditions with CCS within EOR, the project is in loss of around \$7 million. While the project operates for CCS within EOR, it will end up making profit while sequestering the same amount of CO₂.

Chapter 6: CO₂ Utilization for Enhanced Oil Recovery

6.1 Introduction

CO₂ is generated in the environment by natural sources and by anthropogenic sources. It is the main cause of global warming. In order to mitigate the concentration of CO₂ along with sequestration, it must be utilized in useful applications in industry. Currently CO₂ is used in fabric cleaning, fire extinguishers, in wine making & most importantly as working fluid in enhanced oil recovery. CO₂, when used in enhanced oil recovery process, it makes the sequestration of CO₂ more economically viable.

6.2 Enhanced Oil Recovery Using CO₂

Oil reservoirs when put on production, first produce because of their own pressure (primary recovery), after then water flooding is used (secondary processing). But only 30-40% of original oil in place can be recovered by these processes. Rest of the oil remain in the reservoir either because of its immobility or because it get stuck in low permeability zones, which are not accessed by water during secondary processing. So in order to recover that oil enhanced oil recovery is used.

There are lots of techniques available for EOR like thermal EOR, chemical EOR, microbially EOR, and CO₂ EOR. In this project we are concerning CO₂-EOR in the Rose Run Formation (Coal Fex Field, Ohio). In CO₂-EOR, first CO₂ is injected in the reservoir, it displaces the oil in the reservoir, and the oil swells. After that oil is just needed to be pushed towards the production wells, which is done by water flooding.

6.3 Scope & Potential of CO₂-EOR in United States

CO₂-EOR projects accounted for 3.1% of total crude oil produced in USA in 1998. In 2005, oil production from CO₂ -EOR was approximately 237,000 bbls/day. The pie chart below in figure 32 shows the potential targets for CO₂-EOR in United States. Figure 33 shows the amount of oil recovered by CO₂-EOR in U.S. per year since 1985[6.1]. From the pie chart we can see there are vast reserves of oil are available which can be recovered by CO₂. So scope of CO₂ enhanced oil recovery is very bright in U.S.A.

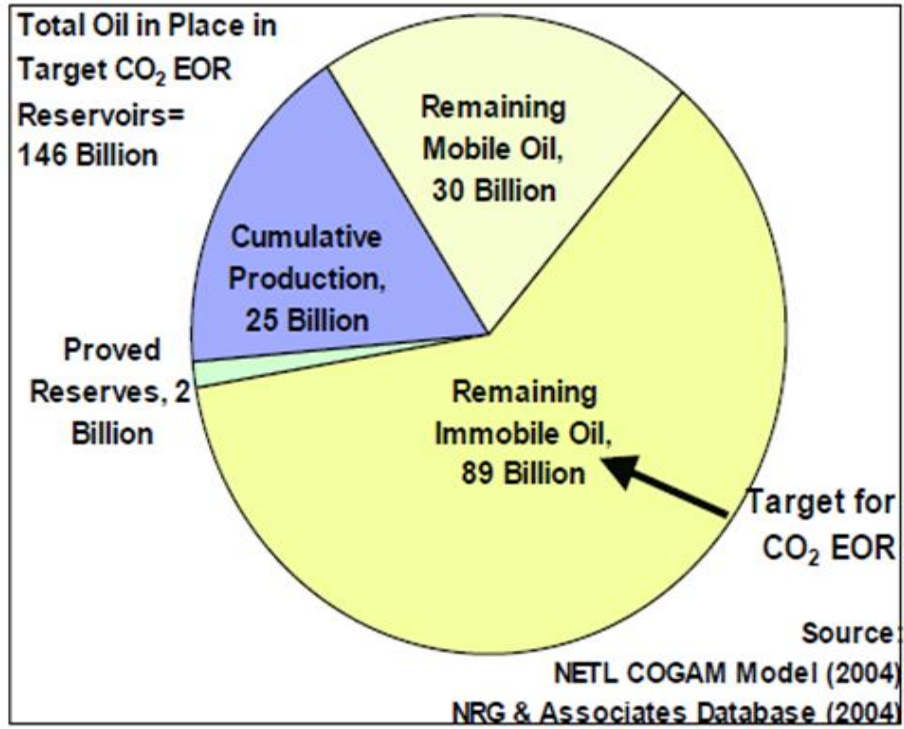

Figure 32: Potential Target for CO₂ EOR

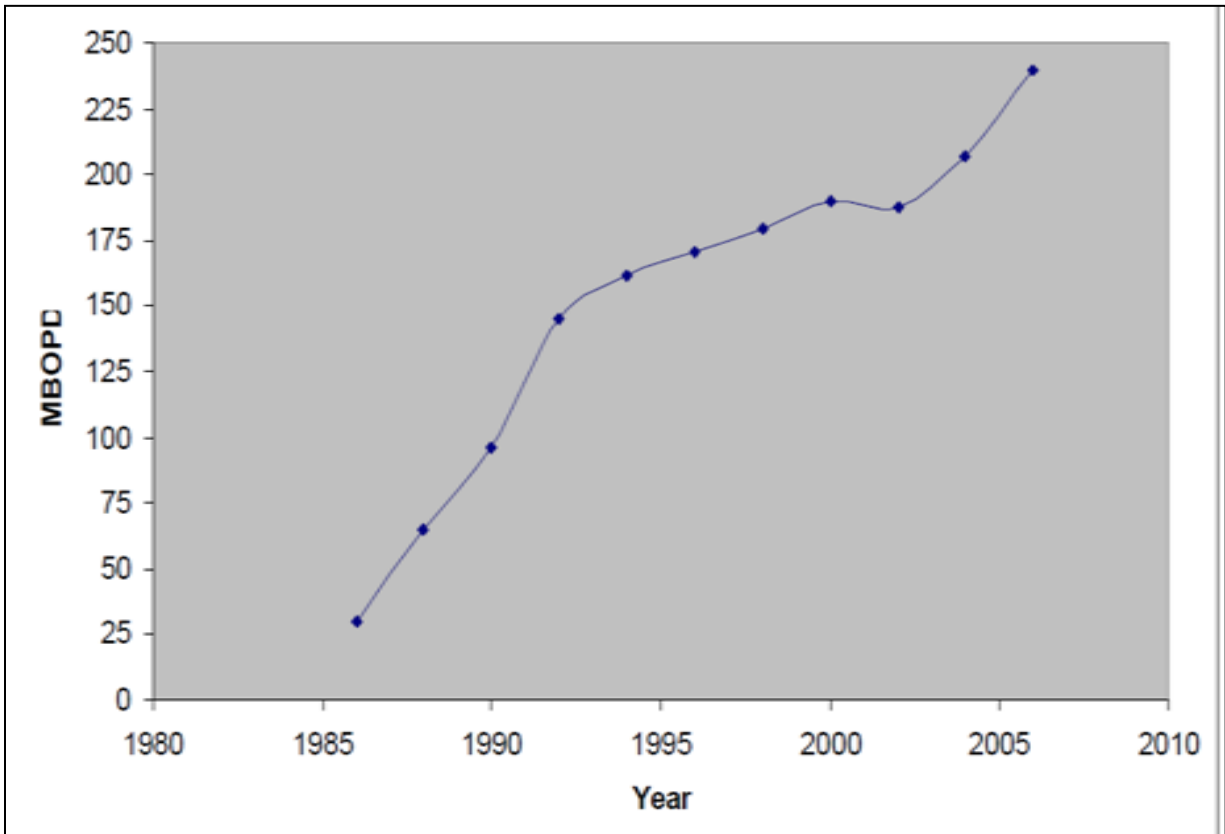

Figure 33: US Oil Production from CO₂ EOR Projects by Year

6.4 Technical Aspects of CO₂-EOR

When CO₂ is injected in the oil reservoir, it displaces the oil. As previously mentioned, CO₂ can be either miscible or immiscible with the oil. Miscibility depends upon the chemical composition of CO₂, composition of oil, temperature & pressure. Immiscible displacement of oil makes the EOR process complex.

Miscibility

Whether CO₂ will be miscible or immiscible can be found by long-tube experiment. Also the pressure at which CO₂ mixes with the oil immiscibly can be found.

The minimum pressure at which miscible displacement of oil occurs is known as Minimum Miscibility Pressure (MMP). So if we find that CO₂ will be immiscible with the oil, by increasing pressure of CO₂ injections we can make the displacement miscible and which will it be beneficial for EOR. In the long slim tube experiment, a reservoir sample is taken and CO₂ is injected at different pressures, & the MMP is found.[6.5]

In our project we are dealing with the Rose Run formation, in which oil is considered equivalent to black oil, so we will go with the assumption that miscible displacement of oil will take place.

Carbon dioxide achieves super critical state when injected in deep formations. In that case properties of gas and liquid phases become identical. At super critical conditions, fluids experience lower surface tension than liquids, which allows it to diffuse easily in the reservoir through small pore spaces. In super critical conditions fluids act as a liquid in terms of density (high density) and as a gas in terms of viscosity (low viscosity).

6.5 Reservoir Fluid & Formation Properties

Table 14 below summarizes the properties of reservoir fluid & formation, when the Rose Run reservoir (Coal Fex Field) was put on production in 1997[5.2].

Table 14: Rose Run Reservoir Fluid and Formation Properties

The specific gravity of the crude oil	0.827 corrected to 60 ^o F
Initial pressure of the reservoir	1700psia ((in 2004) we are including pressure build up so we take Pi=3000psia for our model)
Water saturation	41.8
FVF	1.17-1.21RB/STB
Thickness	27ft(ten layers each of thickness 2.7ft)
Porosity	17.1%
Horizontal Permeability	1 mD
Vertical Permeability	0.1 mD
Compressibility of the rock	$4.0 \cdot 10^{-4} \text{ psi}^{-1}$
Viscosity Of The Oil	0.74cp
Drainage AREA	130ACRE

Based on the above data OOIP (original oil in place was calculated) as 2,207-2,282MSTB. Out of above OOIP, around 12.6% has been produced by 2002.

6.6 Process Description

In order to economize the sequestration of CO₂, sequestration can be done within enhanced oil recovery. Figure 34 below shows the flow diagram of CO₂-EOR with sequestration [6.1]

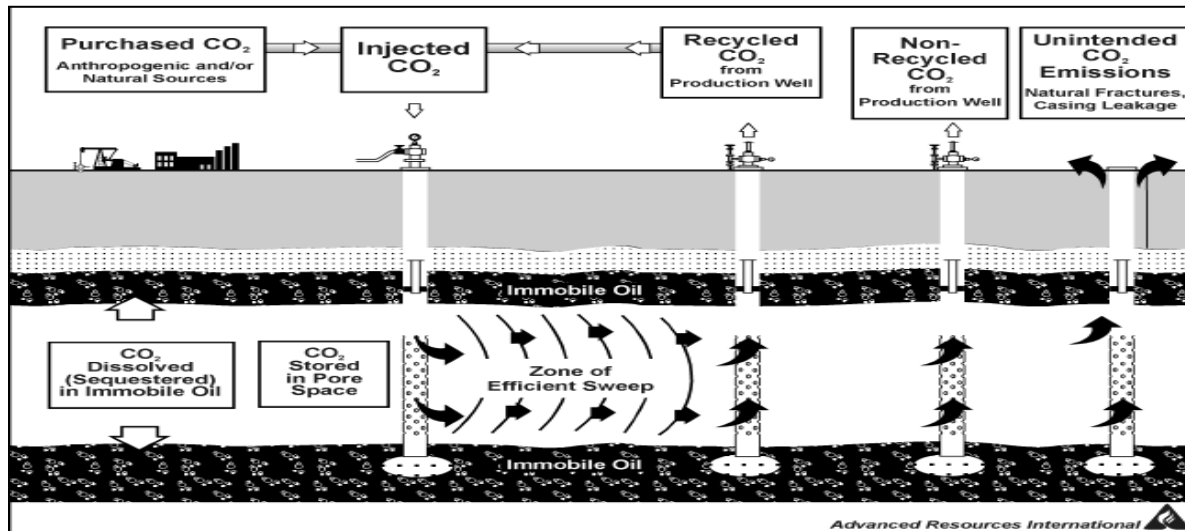

Figure 34: Sequestration of CO₂ within EOR

In general the above process can be explained in the following steps:

6.6.1 CO₂ injection & miscible displacement of oil:

CO₂ from the Shawville plant is transported to the reservoir site once is captured and transported from the plant through pipelines. Then through injection wells, it is injected in the reservoir. A number of wells were drilled in the Rose Run formation, so we can use already drilled wells for injecting CO₂. After injection, it mixes with the oil, and forms a binary mixture. CO₂ displaces oil either miscibly or immiscibly depending on the oil composition. Figure 35 below illustrates the behavior of a binary mixture below 120 of CO₂ and oil from the Wasson field, a large field in West Texas where CO₂-EOR is planned [6.2].

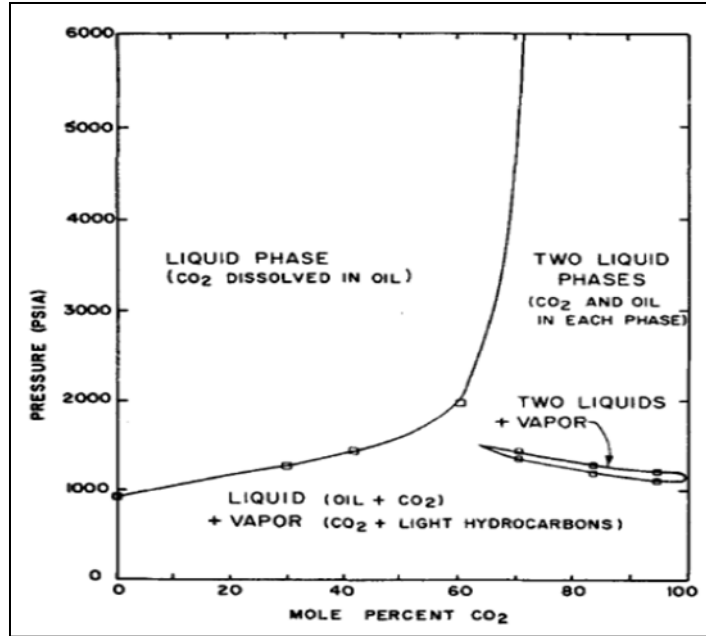

Figure 35: Binary mixture behavior of CO₂ and Oil at 120F

If we assume the Rose Run formation's properties are the same as the Wasson field, then we can come up with the range of CO₂ mole fraction for the miscible displacement of oil. We are considering the Rose Run formation at a 2500m depth. Applying the 10MPa/km pressure gradient, we see that at 2500m depth, CO₂ will be at a pressure of 25MPa when it is injected under normal conditions.

Now as 1 Megapascal is equivalent to 145.04 pound-force/square inch (psi), conversion equates 25MPa to 3625.93 psi. So from above figure 35 we can see that at 3625.934psi, we can handle CO₂ mole fraction from 0.00% to about 70% for the miscible displacement of oil by CO₂, when pumping CO₂ at normal conditions.

When CO₂ is injected in to the oil reservoir, the miscible mixing of oil and CO₂ leads to oil swelling and lowers the oil viscosity, allowing oil to flow to the production wells. The factor which characterize the mobile behavior of any phase is:

$$(k/\mu) \tag{15}$$

Where k= permeability and μ = viscosity of phase.

As μ decreases when CO₂ is mixed with oil, mobility increases.

6.6.2 Production & Wag (water alternating gas)

When oil is mobilized by CO₂ and freed from its residual saturation state, it needs to be pushed or pulled to the production well. For that purpose water driver are used to alternate the CO₂ injection. This process is known as water alternating gas (WAG).[6.1] Figure 36 shows how WAG works in the production of oil [6.1]. In figure 34 the zone of efficient sweep is the zone where WAG takes place. So

water pushes the oil to the production wells, and from the production wells, a mixture of oil, water & gas comes out.

Also CO₂ can be leaked through wells which have been drilled in the past or from the natural fractures, so in order to avoid that CO₂ mixing in environment either we plug the preexisting wells or we try to capture that unintended CO₂ by continuous monitoring after injection.

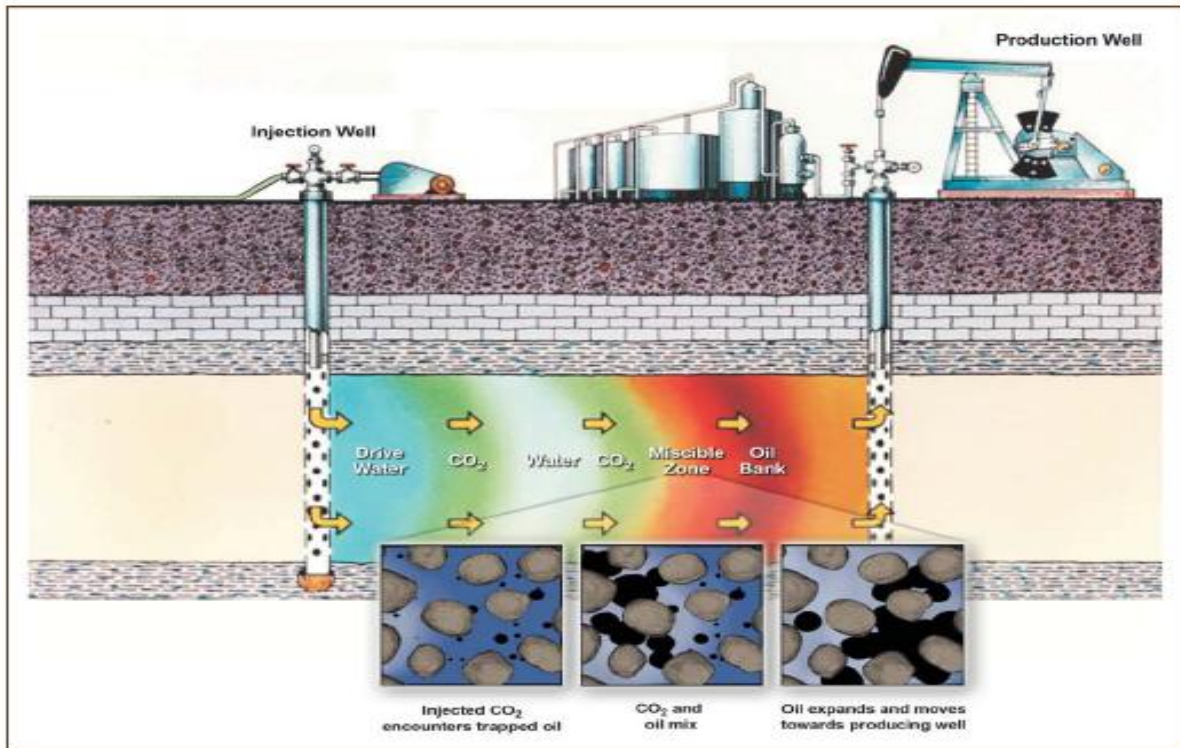

Figure 36: WAG (water alternating mechanism)

6.6.3 Recycling

After production, a mixture of oil, water and CO₂ is sent to the separator, and when feasible, the mixture is processed and recycled with the pure CO₂ from power plant and is reinjected down the injection wells. The treatment of CO₂ for recycling can be done by using amine (DEA) adsorption processes, extractive distillation techniques or membrane separation. All these processes are electricity intensive. In our project, we see that we do not produce much CO₂, so recycling of CO₂ is not going to be too expensive; however we are considering the recycling of CO₂ as well.

6.6.4 Sequestration

Some of the injected CO₂ dissolves into the immobile oil resources and remains trapped in the reservoir. Carbon dioxide remains in the reservoir by primary trapping mechanisms like structural trapping and residual CO₂ trapping. After EOR is completed and the reservoir is declared dead, alkalinity is introduced in to the formation by injection of Ca (OH)₂ in order to enhance forced mineral trapping. That is the advantage of doing EOR; we make profit by selling CO₂ and also we sequester CO₂ at the same time.

6.7 Modeling of CO₂-EOR

A model has been established for CO₂-EOR in coal-Fex Field, using CMG simulator. Figure 37 below shows the basic reservoir and well locations in the reservoir.

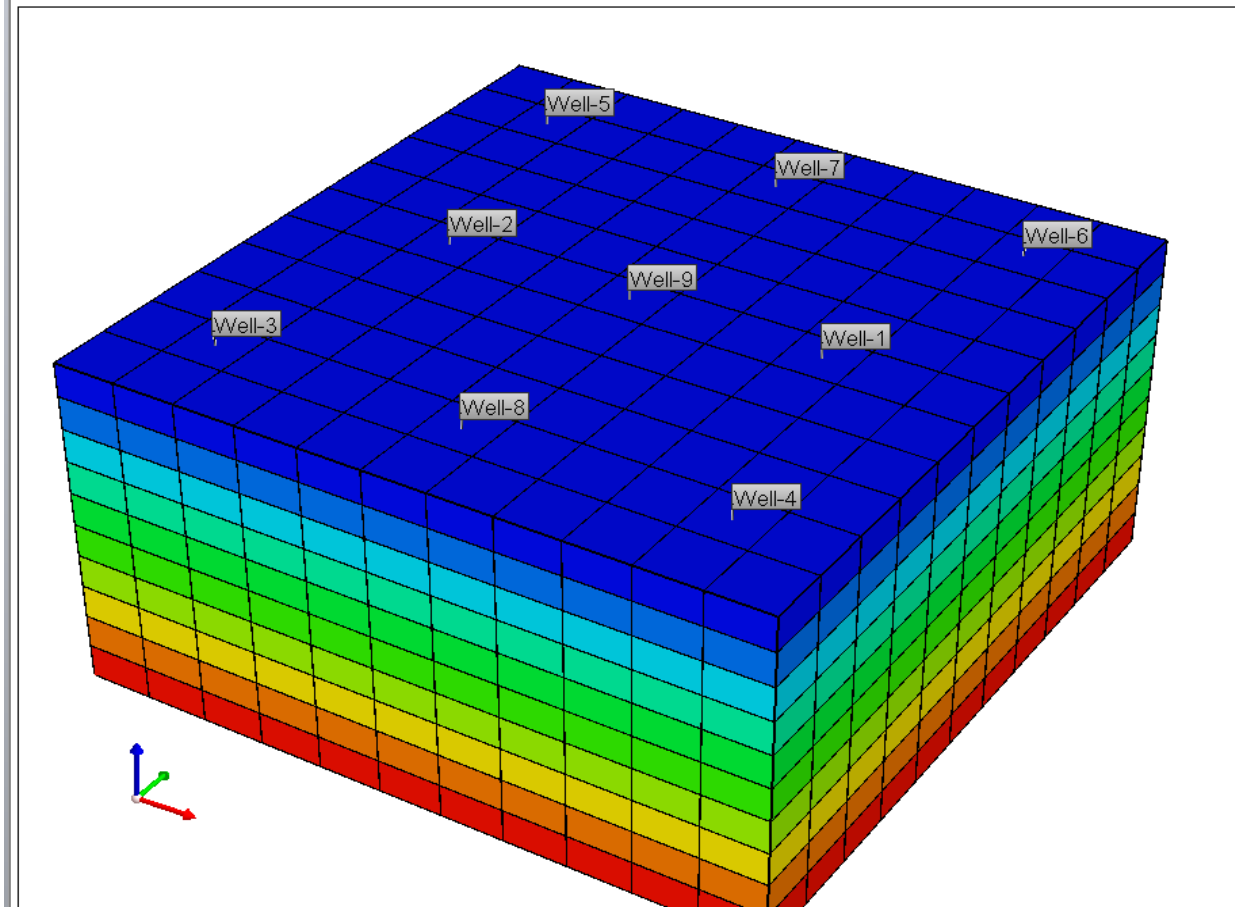

Figure 37: 3-D representation of the field

A total of ten layers have been considered and the thickness of each layer is 2.7 ft.

EOR will be done for the first ten years. After ten years, only injection of CO₂ will occur, and we will shut down all the production wells. Wells 1, 2, 7, 8, 9 are injection wells. Wells 3, 4, 5, 6 are production wells during the first ten years.

Oil is produced for the first ten years, and then wells 3, 4, 5, 6 are converted into injection wells. Also, as in ten years, well block pressure in wells 1, 2, 7, 8, 9 will increase, so we cannot continue injection in these wells. Otherwise it will cause fractures in the formation. So these wells will shut down after ten years. After ten years, we switch to injection in wells 3, 4, 5, 6 which have been converted into injection wells.

6.8 Results

The simulation model was run for ten years to find out the amount of oil produced. After that production of oil has stopped and the production wells are converted into injection wells. The injection wells used for first ten years also shut down after EOR processes.

All models are run for 30 years, from 2011 to 2040. As CO₂ is injected into the reservoir, pressures within the reservoir increase and CO₂ tends to fill the pore spaces and displace the oil forward towards production zones. The production wells will sense an increase in production rates due to increases in pressure gradients between the sweeping and residual fluids. Figure 38 below shows the cumulative injection of CO₂ over a period of ten years during EOR and figure 39 shows the cumulative injection of CO₂ over a period of 30 years. The cumulative amount of CO₂ injected from 1 well in ten years is 1.1022×10^{11} scf, and the cumulative amount from all five wells is 5.511×10^{11} scf.

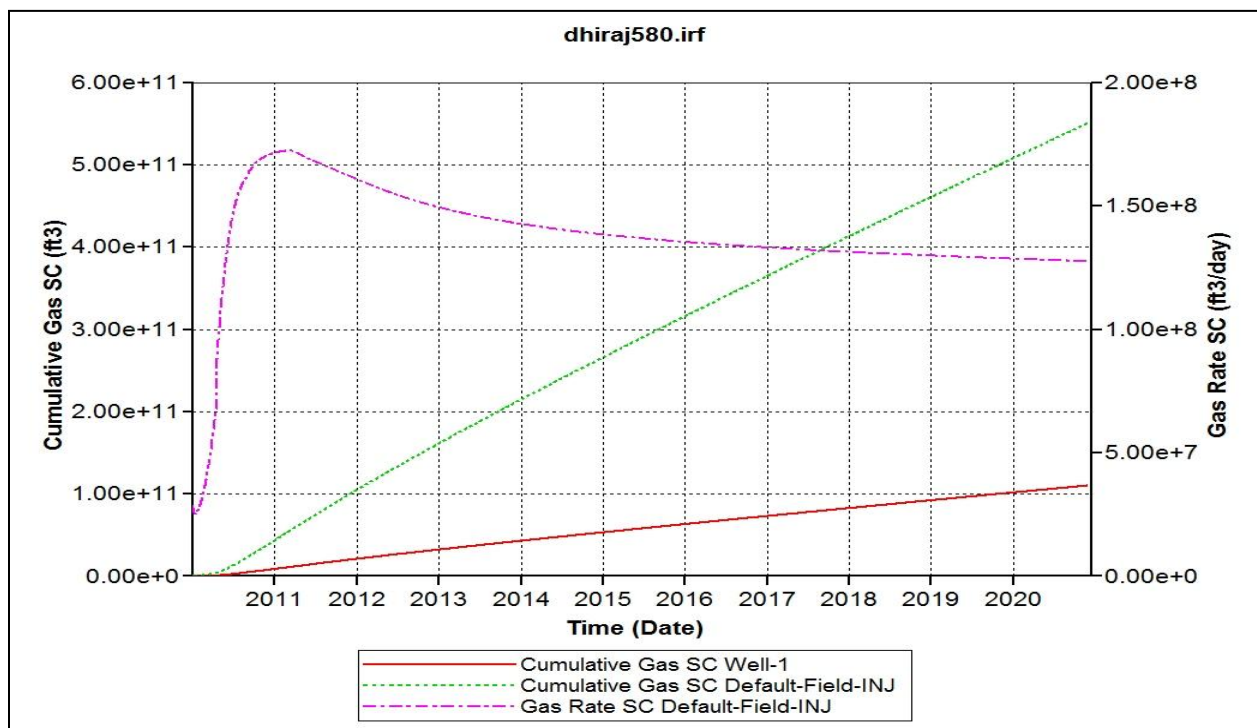

Figure 38: Cumulative injection of CO₂ during 10 year EOR period

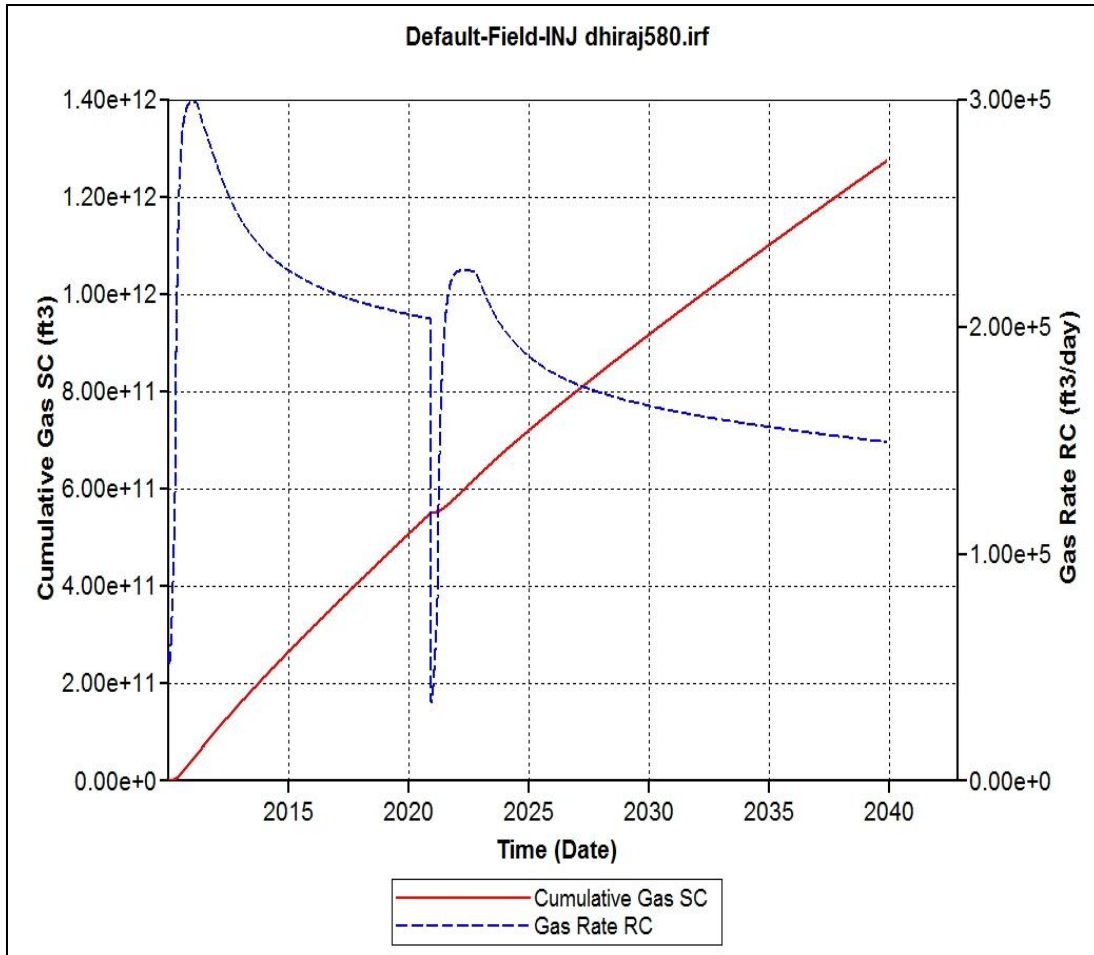

Figure 39: profile of CO₂ injection over 30 years

Cumulative CO₂ injection from the field using the model above in 30 years = 1.274×10^{12} SCF (15)

We see that pressure in the well block reaches approx. 11,000 psia, so in order to avoid the fracturing of the formation; we stop the injection after 30 years. Rates of CO₂ injection increase at first and then decrease as well block pressure is low. Figure 40 below shows the field cumulative oil production, cumulative oil production from 1 well and the rate of production of oil. The amount of oil produced in these ten years is 406614 barrels. As previously mentioned OOIP of the field is approximately 2250 MSTB, so we produce about 18% of OOIP. CO₂ and water will also be produced along with the oil, however we see that amount of water is almost negligible (1-2bbl/d), so it is not consider in the cost of separation of oil from water. The amount of CO₂ produced is very low. We will install a CO₂ recycling plant to recycle whatever the amount of CO₂ is produced. Figures 41 and 42 show profiles of CO₂ and H₂O production over ten years. The amount of water and oil produced after 10 years is 6895.67bbl and 7.26 million bbl, respectively.

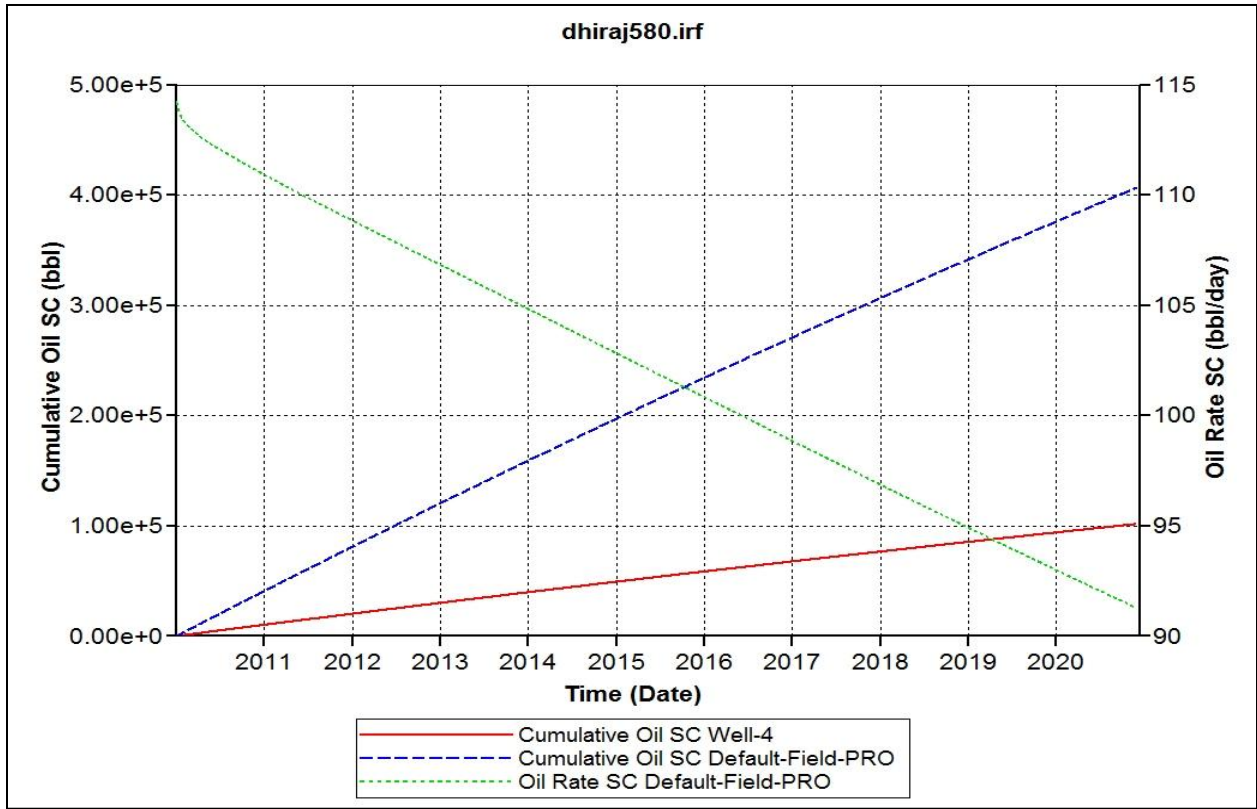

Figure 40: Cumulative oil production from well 1

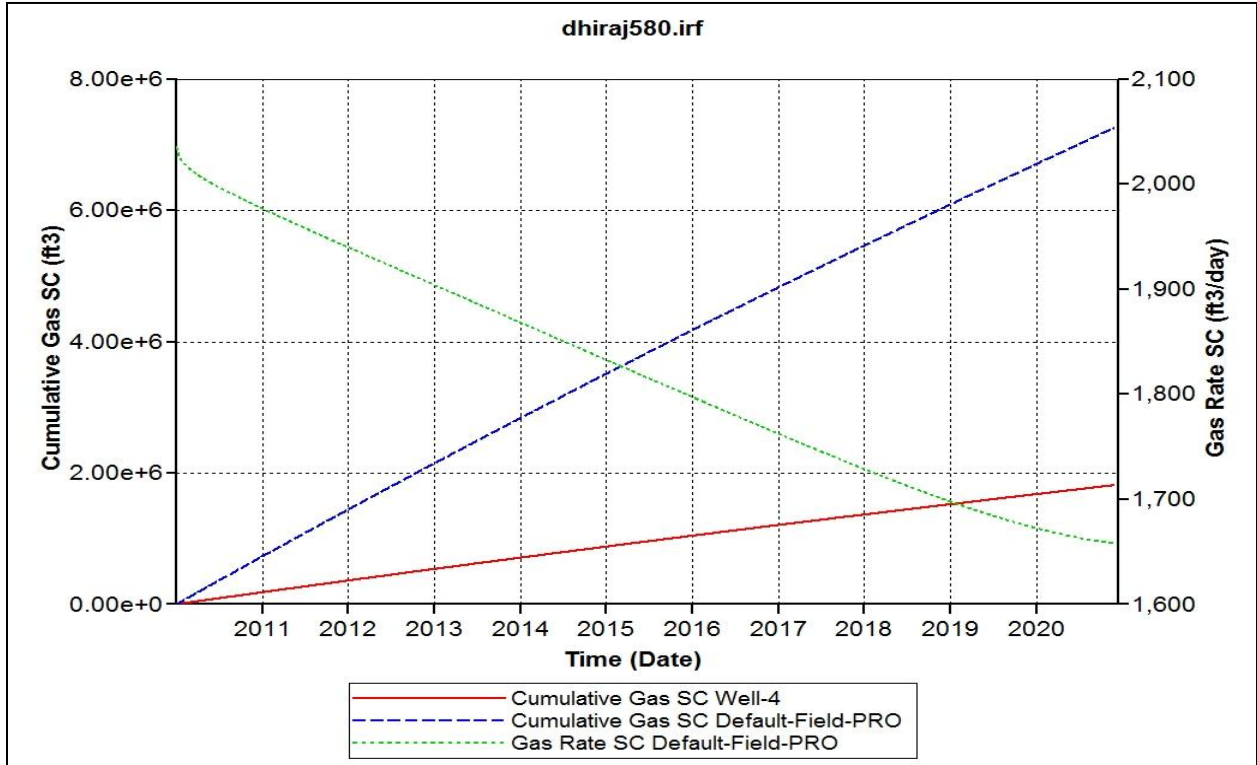

Figure 41: Profile of CO₂ production

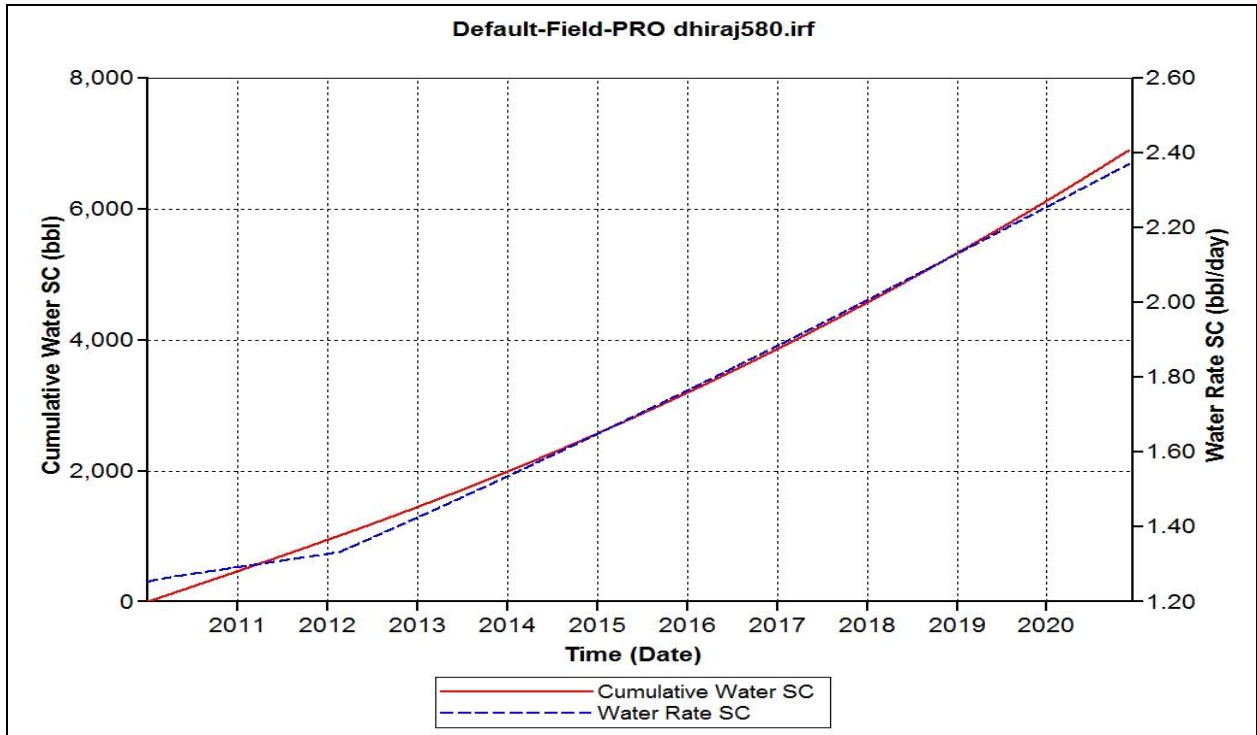

Figure 42: Profile of H₂O production

We also need to keep in mind the pressure of the formation should not exceed 12,000 psia (which we have assumed as fracture pressure of the formation). Figures 43 and 44 below show the pressure profiles of the formation after 10 years and 30 years, respectively.

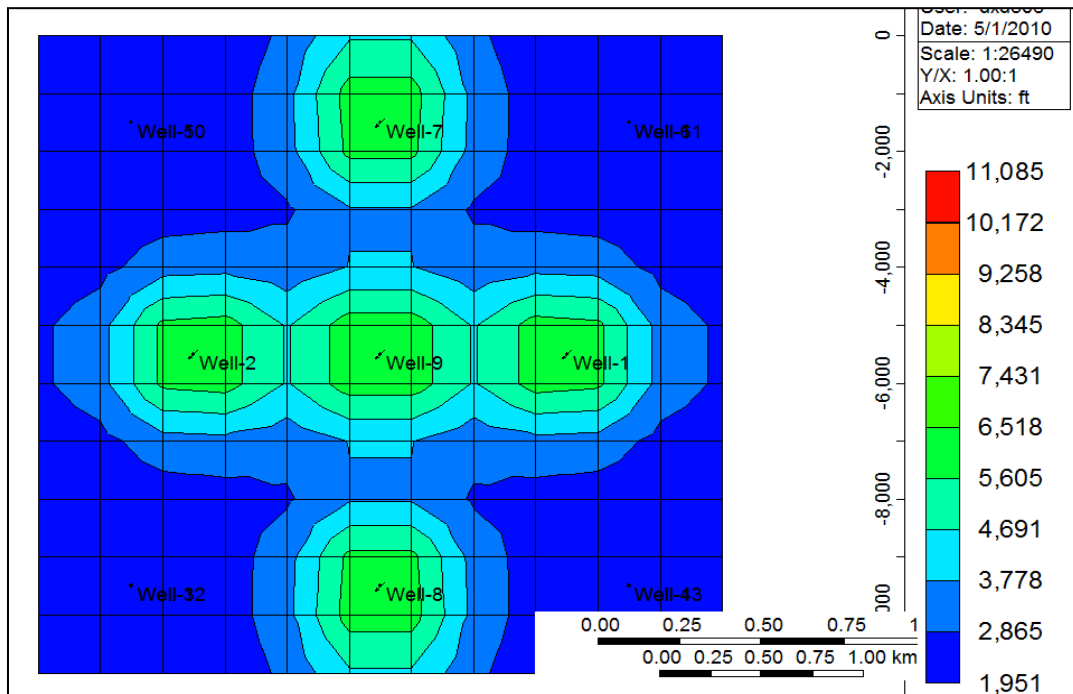

Figure 43: Pressure profile after 10 years of operation

We see that after 10 years, pressure is at its maximum in well blocks between 9900-10000psia. So in order to avoid further increases in pressure we, shut down in all wells and then new injection wells (production wells which have been converted into injection wells) are used.

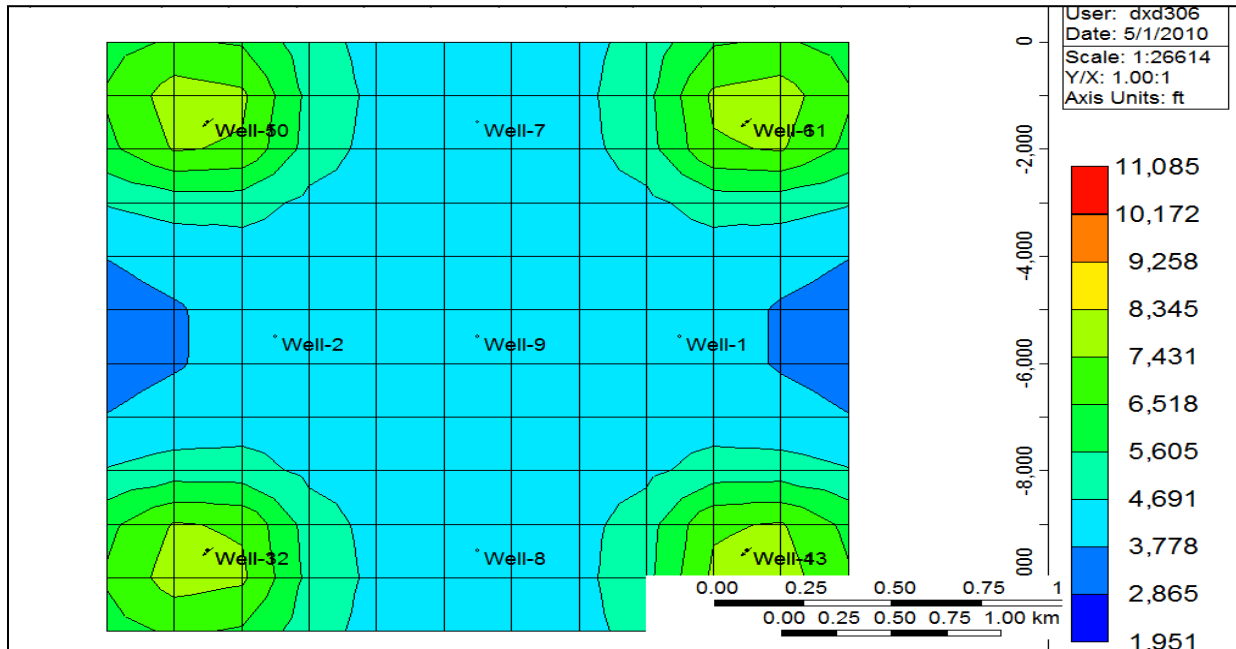

Figure 44: Pressure profile after 30 years of operation

After 30 years, we see that the pressure is at its maximum in the injection well blocks at around 11,000psia. So now we terminate the injection process, as not to exceed the fracture pressure limit of the formation.

6.9 Economic Analysis of Sequestration With in EOR

In making an economic analysis of EOR, we assume that the CO₂ is available at the site after transportation. We do not consider the capture cost, transportation cost and monitoring cost for the EOR.

Also, because we are doing secondary recovery, we do not need to drill new wells. Wells already drilled in the formation will be reworked and the cost of reworking will be considered.

These costs will be considered in the ultimate cost analysis. We will neglect the cost of injecting Ca(OH)₂, which will be injected after EOR for enhancing mineral trapping.

The purpose of the economic analysis is to evaluate the feasibility of CO₂-EOR. The main source of income in this process is coming from the recovery of 406.614 MSTB of oil. Major costs include the cost of O&M of wells and the recycling cost of CO₂. Table 15 below shows the economic analysis of EOR and includes the costs involved in EOR.[6.6]

Table 15: Economic analysis of EOR

VARIOUS COSTS ASSOCIATED	PER WELL PER YEAR(\$)	TOTAL(MM\$)
reworking on existing wells	181968.75(constant for 1 well)	-1.64
operating & maintenance costs	111863.75 /year/well	-10.0677
CO ₂ recycle cost	700,000Per MMcf/d	-5.131
CO ₂ recycle O&M cost	1 per Mcf	-0.0733
Lifting costs	0.3per bbl	-0.122
G&A costs	27965.9.2+0.2*(0.3per bbl)	-2.0379
royalties	12.5% of total oil production	-4.57
Income from oil	90*406614	+36.59
total		+ 12.95

In table 15, (-) signs indicate expenses, and (+) signs indicate revenue. We use set oil prices at \$90/bbl, over the ten production years. We see that a profit of \$12.95 million is obtained in 10 years from CO₂-EOR. We not only make this profit, but we also sequester ten years emissions of CO₂ from the plant. When the above economic analysis is compared with economic analysis of CCS without EOR, we see that we make profit while achieving sequestration.

Chapter 7: Monitoring of Underground CO₂ Reservoirs

7.1 Introduction

Carbon capture and storage (CCS) may function as a means to successfully store anthropogenically produced carbon dioxide (CO₂) for tens of thousands of years through geologic sequestration [7.1]. Long-term underground storage of CO₂ is a naturally occurring process most often observed in sedimentary basin in which pore spaces between clasts are infilled with gases, liquids, or supercritical liquids [7.2]. Enhanced oil recovery projects (EOR) projects have previously injected carbon dioxide into low outputting petroleum and natural gas wells to re-pressurize the reservoirs and encourage the migration of desired gases [7.3]. These projects have proven themselves successful and though there may be high capital project costs, there are many cost incentives through enhanced oil and natural gas production. An issue that remains is the related environmental and human health and safety issues from underground CO₂ injection. These issues are best understood through ongoing monitoring of CO₂ injection in order to characterize the effectiveness of long-term, underground sequestration. There are currently several suggested methods for monitoring underground CO₂ reservoirs and each has respective cost and benefits.

7.2 Statement of Purpose

The purpose of this investigation is to understand currently available monitoring technologies and apply their use to an underground CO₂ injection project in the Rose Run formation underlying a coal fired power plant located in Shawville, PA. This CCS project will have many associated retrofitting, transport, and injection costs, so it is the intention of this environmental health and safety survey to suggest sufficient monitoring methods at the lowest possible costs. To do this, existing monitoring networks across Pennsylvania will be utilized in order to minimize monitoring costs of the injection reservoir. Technologies will be adapted from the petroleum and natural gas and industrial health and safety industries as well as departments of environment protection to develop a complete and cost effective regional monitoring network above the Rose Run formation (RRF).

Before implementing a CCS retrofitting project in Shawville in, a complete risk assessment must occur to quantify the likelihood of damages if leakage were to occur. In order to successfully manage these risks, the costs and benefits of the project must be weighted to develop a logical and systematic approach to recognizing and reducing these risks. The frequency and likelihood of associated hazards for this project should be determined and the ultimate impact of geologic carbon sequestration must be understood. Hazards include exposure to harmful levels of CO₂, damage to groundwater and mineral resources, induced or enhanced seismicity, and the injury associated with projects [7.37] The primary sources of leakage (places of close proximity to hazards) are found along the pipeline transport networks, at pumping stations at the capture or injection stations, or from the geologic sequestration site.

7.3 Reservoir Assessment

7.3.1 Pre-injection Assessment

The regional geology of the RRF and the local water table must be considered before any injection programs can occur. A pre-injection assessment is critical to predict how injected induced pressures will affect reservoir characteristics. The Rose Run formation is located at a depth of 2500 meters and extends under Ohio, northern Kentucky, West Virginia, southwestern New York, southern Ontario, and Pennsylvania. Dozens of faults have been identified along the northern Appalachian Mountains, north-eastern Ohio, north-western Pennsylvania, and the eastern basin of Lake Erie [7.4]. These faults are predominantly southeast-northwest trending and may extend to thousands of meters in depth. Existing geologic surveys and LIDAR maps should be catalogued to identify and characterize land deformation due to injection. Tens of thousands of historic and active petroleum and natural gas wells cover this region and in addition to the faults, these wells are the greatest point sources for CO₂ leakage [7.5]. Potential leakage pathways must be identified prior to injection to reduce risks to environmental or human health as well as reduce future project costs relate to the management of these leaks. Recent investment into natural gas projects within the Marcellus shale will provide critical information about regional borehole well locations. Additionally these projects have ample subsurface data related to geological and mineralogical characteristics, aquifer depths, brine geochemistry, and reservoir temperatures and pressure information. Utilizing these operations existing data and background information can reduce our survey costs. After these parameters are thoroughly assessed and leakage risks are characterized, injection into the Rose Run formation may proceed.

7.3.2 Injection Monitoring

Monitoring of injected CO₂ is necessary to understand how a plume stabilizes or migrates within a reservoir in order to determine how long carbon dioxide can successfully be sequestered at a site. Site characterization of faulting and fractures must be understood in order to predict any migration or dispersal into local aquifers, which can pose risks to human and environmental health. These locations may serve as suitable monitoring sites because if CO₂ were to leak out of the reservoirs, it would flow along these paths of least resistance. The reservoir capacity and characteristics needs to be completely understood to successfully inject supercritical or liquid CO₂ into the formation. If the geologic site has sufficient porosity (space between clasts) and permeability (connection between pore spaces) in addition to impermeable cap-rocks, a site may be appropriate for underground injection. Figure 46 highlights appropriate injection rates within the Rose Run. The potential types of leakages that may occur at a sequestration site must be understood before deciding which type of monitoring should be employed. Between 0.10 and 0.35 Mt CO₂/year/well can be safely injected into the Rose Run formation. These injection rates allow for the desired diffusion rates into the reservoir while maintaining CO₂ in it the liquid or supercritical liquid form as well as the desired reservoir pressures [7.6]. Exceeding these injection rates may result in plume instability, a CO₂ phase change from the supercritical to the gaseous state, and CO₂ migration out of the reservoir.

Leakage or seepage can most readily occur from sites of well injection. As pressures within a reservoir build, gases or liquids will attempt to migrate to areas of lower pressure. By understanding fluid movements within a reservoir, models can be produced to better understand fluid migration and leakage [7.7]. The injection well often serves as a potential leakage source because it is directly connected to the primary reservoir. Wellhead injection rates, pressures, and temperatures must be understood and monitored to ensure proper sequestration and only ongoing observations will provide the necessary information to recognize the maturation of a sequestration site [7.8]. Because underground injection is a long-term sequestration strategy (tens of thousands of years), monitoring must be on going to ensure that the reservoir maintains desired pressures and characteristics. Understanding reservoir geochemistry is essential to the long-term sequestration of injected CO₂. Over time, geochemical reactions within the reservoir may dissolve certain minerals and open avenues for seepage. Old or abandoned mines, petroleum and natural gas wells pose similar risks to the primary injection well, again because building pressures can encourage plume migration. Because the Rose Run formation exists under a region of thousands of square miles, leakage pathways may develop across the reservoir. These abandoned well sites may serve as point sources of seepage and if they can be identified, these sites are excellent candidates for monitoring sites [7.9]. Faults and fractures provide additional point sources for seepage and only proper identification of these geologic features can ensure the overall viability of a sequestration site. With these sources of leakage in mind, several methodologies have been developed to monitor underground CO₂ leakage. Technologies will be adopted from the oil and natural gas industries for monitoring injected CO₂.

A majority of the detection technologies and risk monitoring of the CO₂ pipeline networks can be borrowed from existing pipeline networks developed by the oil and natural gas industries. Pipelines should avoid concentrated human populations to minimize any hazards associated with pipeline failure.

The pipeline infrastructure needs to be continuously monitored for leaks or signs of corrosion and pressure must be maintained during transport. Unlike the oil and natural gas transportation, the threats of explosions are minimal but if leakage were to occur, CO₂ gas may accumulate along lower lying topographies and threats of suffocation or carbon dioxide induced sickness may occur. Options may include adding some sort of chemical odorant to the transported CO₂ to act as a cheap early detection proxy [7.37].

Geologic sequestration site monitoring is essential to reduce the associated hazards from carbon dioxide leakage. The Rose Run formation has been determined to be a suitable site for retaining CO₂ for thousands of years. As seen in figure 47, there are many abandoned oil and natural gas wells that may serve as vectors for carbon dioxide leakage. After identifying these abandoned oil and natural gas wells, those deemed likely to serve as point sources of leakage must be properly plugged to ensure the long-term stability of the sequestration reservoir. It is vitally important to understand reservoir maturation through ongoing monitoring to determine if leakage was to occur, would it be a chronic, small scale leak or an acute, catastrophic large discharge scenario.

7.4 Monitoring Techniques

7.4.1 Optical Fibers

A majority of the monitoring technologies that can be applied to geologic sequestration sites have been developed by the oil and natural gas industries. Optical fiber sensors have previously been employed in natural gas wells as downwell sensors that respond to varying reservoir characteristics. Regional monitoring networks of these optical fibers can be utilized to create underground reservoir pressure maps that can then be used to characterize any gas migration within the system [7.10]. This technology has been successful in oil reservoir modeling, but large-scale applications to carbon sequestration sites and the associated costs have not been fully explored. While the costs for application towards a project like the RRF remains uncertain, optical fibers are easily installed or replaced, cheap to use and extremely effective in measuring reservoir properties [7.11]. Because the RRF is a vast geological formation, site location for these optical sensors is dependent on the pre-injection assessment. If leakage pathways have previously been identified, regional optical fiber networks should be installed in already existing, functioning or abandoned wells or in the direct injection wells to minimize associated drilling costs. Brown and Hartog (2002), suggest that the cost may as low as \$20 per sensor, but a National Energy Technology Laboratory (NETL) study conducted in 2006 to assess methane leaks required an operational project budget greater than \$550,000 [7.12]. An optical fiber network contained within a 25-mile radius of the Shawville plant should provide a sufficient monitoring network for this injection project [7.13]. Figure 48 highlights this 25-mile radius feature because it is believed that injection into a reservoir within this geographical scale will prevent a potential overlap between other regional power plant injection schemes. If other coal-fired power plants enact similar geologic sequestration strategies, the costs with this regional optical fiber network may be reduced if each plant enters a regional monitoring network partnership. A partnership of this nature would provide a better of assessment of environmental health through a more complete identification of reservoir characteristics or leakage pathways. In addition to optical fibers, alternative sensor systems exist and these types of devices may

be useful for modeling underground carbon dioxide. It seems, however, that optical fibers may be most cost-effective for the purposes of a sequestrations project within the Rose Run formation. Above ground detection devices are also readily available and are proven tools in detecting carbon dioxide in soils, water tables, and air. These additional techniques may also be used.

7.4.2 Gas Detection

The environmental health and safety industries have also developed a variety of monitoring tools for CO₂ detection, which observe carbon dioxide concentrations within a water table, soils, and surface air [7.14]. These monitoring techniques are well understood and can easily be applied to the areas above an injection well to model any sources of seepage or leakage. Because CO₂ dissolves in water to form carbonic acid, simple pH monitoring of regional lakes and rivers can provide critical information about point sources of reservoir seepage. Gas chromatography and IR detection are additional monitoring tools that have been implemented by occupational health and safety groups and have proven successful in atmospheric detection of carbon dioxide [7.15]. Monitoring tools used to understand volcanic activity may also be applied to a sequestration site. Variations in CO₂ emissions from active and dormant volcanoes have been successfully observed by the USGS using LI-COR detectors and if sensor networks are applied to a sequestration site, reservoir leakage models can be created [7.16,7.17]. Volcano monitoring devices may prove extremely useful if these technologies are applied to sequestration reservoirs if they are cost-effective. Remote sensing devices, specifically satellites have been used to monitor atmospheric carbon dioxide concentrations, but this technology has previously been unable to detect low-concentration leakage and may not be appropriate for onsite detection [7.18]. While some of these technologies are potentially costly, some are already in use for general environmental monitoring. The scales of geologic sequestration sites can be immense and multiple forms of monitoring devices may need to be employed to develop an efficient characterization of CO₂ injection. Monitoring will only prove successful if it is cost-effective and reliable in characterizing CO₂ leakage to prevent damages to humans and ecosystem health [7.19]

International space agencies have already devoted substantial resources to the detection and monitoring of the carbon cycle. While these projects are extremely expensive, we can utilize their networks to further develop our Rose Run formation monitoring network. The National Aeronautics and Space Administration (NASA) and the Japan Aerospace Exploration Agency (JAXA) have put several important satellites into orbit that freely provide information to the public related to their observations. Airborne laser swath mapping (ALSM) can be used in monitoring ground deformation. NASA's Orbiting Carbon Observatory (OCO) suffered launch failure in February of 2009 (a \$250 million loss to taxpayers) but has received 2010 budget approval for \$170 million. When re-launched, the OCO project can be used to monitor and identify carbon fluxes on extremely small spatial scales [7.38]. If significant leakage were to occur, this satellite could successfully identify and quantify the leakage. JAXA launched the Greenhouse Gases Observing Satellite (GOSAT) in January of 2009. This satellite, like OSO, has centimeter scale resolution in monitoring carbon fluxes [7.39].

7.4.3 Geochemical Monitoring

Past land-use histories must also be considered specifically related to abandoned mines, oil, and natural gas wells, which can serve as point sources for CO₂ leakages [7.20]. This background environmental

information is critical for understanding and qualifying changes that may occur from underground injection of carbon dioxide.

Geochemical tracers are excellent tools for understanding the physical status of injected carbon dioxide as well as the interactions that occur between the CO₂ and the other minerals and chemicals that may exist within a geologic reservoir [7.21]. Work by Gunter *et al.*, [7.22] suggests that by collecting fluid samples from bore wells, real-time monitoring of a CO₂ reservoir can create useful models that characterize fluid migration and reactions. Isotopic measurements of these collected bore well fluids can also convey the movements and interactions of injected carbon dioxide within the reservoir [7.23]. The previously described monitoring techniques are well understood, but the related costs and effects of the interactions between injected CO₂ and the local geologic makeup need to be further studied. Their application may be limited in our Rose Run project because of potentially high associated costs. Regional water quality networks are already being used by environmental agencies and Marcellus shale operations extensively collect these bore well samples. Our project may be able to reduce its costs by utilizing these existing monitoring and collection networks. The costs may still be substantial, but necessary to protect environmental health.

Data collected from well logs though potentially costly, are proven tools in detecting CO₂ migration. A variety of devices exist that can be inserted into an injection well to collect and characterize the data to better model an underground CO₂ reservoir [7.24]. Fluid analysis of well-logs can be used to determine the time-lapsed effects of CO₂ injection. By analyzing fluids across a reservoir, migration modeling can determine how and where injected CO₂ is chemically reacting within a reservoir [7.25]. Geophysical models including gravitational, seismic, and electromagnetic analyses have been employed in other fields to understand reservoir characteristics and these same technologies can be applied to sequestration sites [7.26]. Physical observations from satellites, LIDAR, and on the ground observations can be implemented in order to assess the land surface deformation that may result from reservoir injection [7.27]. The implementation of these detection methods must be based on the limitations and accuracy of the detection devices and how specifically these detection methods isolate the effects from underground CO₂ storage from background reservoir characteristics. When all these pieces of information are connected, three-dimensional seismic models can be created to observe any migration of CO₂ within the reservoir [7.28].

There are several associated risks to environmental and human health related to an underground CO₂ injection project. Increased reservoir pressures may activate faults or fractures, causing land subsidence or deformation and induced seismicity may occur from injection [7.29]. Dependence on national and regional seismic networks will be critical for monitoring any land movements. Perhaps the greatest threat to human and environmental safety is the mobilization of heavy metals. pH changes in reservoir geochemistry resulting from carbon dioxide injection may encourage the dissolution of certain heavy metal containing minerals [7.30]. These heavy metals may migrate within or out of the reservoir and end up intruding into regional aquifers. Monitoring of these heavy metals could potentially be extremely costly if we installed our own detection network. Instead, we can use an already established Pennsylvania Department of Environmental Protection (PDEP) water-monitoring network. By comparing historic water quality data to post-injection data, we can back track and potentially locate point sources

of heavy metals and identify leakage sites. Figure 49 shows sites of ongoing water monitoring in Pennsylvania. Several of these sites overly our sequestration reservoir and can serve our project's monitoring purposes. Comparisons of historic data to newly acquired data after injection can prove useful in ongoing site monitoring. Figure 50 shows the major aquifers that underlie the region around Shawville. Any observed impacts to water quality would likely occur in these aquifers.

7.4.4 Bio-monitoring

While many monitoring devices utilize advanced technologies, bio-monitoring may prove to be the simplest and cheapest method to observe potential leakage sites of carbon dioxide. An assessment of ecosystem diversity before a site is used for underground CO₂ storage can provide important background information about ecosystem health. After reservoir injection, ongoing observations of changes in the ecosystem health can be used to determine if leakages are negatively impacting local flora and fauna and specifically locate sources of seepage [7.31]. Because carbon dioxide is heavier than air, it tends to settle in low-lying areas or accumulate within soils. When enough CO₂ accumulates, gases can kill trees, bacteria, fungi, and when conditions are extreme, animals in these areas can suffocate [7.32]. Trees are further susceptible to changes in soil pH and the interaction of carbon dioxide and ground water may encourage changes in soil profile chemistry and lead to tree mortality. Figure 51 shows an image taken by the USGS of tree kill on Mammoth Mountain that resulted from CO₂ fumaroles. Similar tree kill may occur from carbon dioxide leaks at the surface and ongoing forest assessments may prove useful for monitoring purposes.

Beyond already existing forests, tree planting schemes may provide several potential benefits. A form of bio-sequestration, these trees may financially benefit the Shawville plant through some form of carbon credit scheme and additional profits may be gained from the sale of timber. Trees can additionally provide landscape stability that may reduce the threats from land deformation. Figure 52 shows the currently land-use demographics for Pennsylvania. Pennsylvania is well-endowed with forest resources and we can utilize these resources for leakage monitoring and potentially a source to generation profits from biomass sales. To enhance these forest monitoring networks, ideally we would enact large-scale forestation plans. Pennsylvania legislators have already suggested several tree planting plans, but the region around Shawville appears to have reached an equilibrium between agricultural and forest resources. Forestation opportunities, however, do exist because of increasing tree mortality over the last decade. The forested regions around Shawville have been heavily impacted by gypsy moth and silk worm induced tree kill. Over 400,000 acres of formerly forested land are poised for reforestation projects. Using conservative tree plantation estimates, over 176 million trees could be planted across this area, creating more than 80,000 tons of biomass that may be available for future harvest [7.40].

The greatest benefit from bio-monitoring may be its precision in locally identifying point sources of environmental degradation [7.33]. Through ongoing bio-monitoring, leakages can be identified and because this monitoring method may require only observation, it can be quickly and cheaply implemented at a geologic sequestration site.

7.5 Costs associated with monitoring

Monitoring is an essential component of the application of CCS technologies. Monitoring techniques will only prove useful if they are efficient and cost-effective. Two approaches are taken to addressing the costs of monitoring at this project within the Rose Run formation. The first approach of cost analysis will be based off of an “envisioned, all encompassing monitoring network.” The second cost analysis approach will be based off of more standardized industry cost assessments.

This “envisioned monitoring network” will include already installed monitoring devices and those that will need to be implemented on behalf of the project. Table 16 highlights the determined associated monitoring costs with a CCS retrofitting project in Shawville, PA. The costs associated with our project include ground deformation sensors, borewell sensors, biomonitoring, and water quality monitoring. LiDAR technologies can be used to monitor the region around Shawville at cost of approximately \$0.05/acre and cost the overall project \$1.6 million dollars per year [7.41]. Borewell costs include the cost of drilling eight monitoring wells and inserting optical fiber sensors. These technologies will cost the project \$80 million over the lifetime of the project. Biomonitoring costs are based off of a reforestation plan across the 400,000 available acres. At a cost of \$840 per acre and at a plantation scale of 440 trees per acre, \$336 million dollars would be needed for the forestation monitoring project during the initial year. During the lifetime of the project, taking the average value of a mature hardwood tree at \$3.23 per tree, we could generate \$568 million dollars in profit from the sale of timber [7.42]. The costs of using GOSAT and DEP Water Quality networks will not add additional costs to the monitoring project.

Table 16: Cost associated with geologic sequestration project near Shawville, PA

Monitoring Device	Cost (\$)/year 1	Benefit (\$)/lifetime
LiDAR	1,612,274	0
Borewell Sensors	80,000,000	0
Biomonitoring	336,000,000	568,480,000
DEP Water Network	0	0
GOSAT	0	0
Total Costs	-	+150,867,726

These cost assessments can only be considered crude estimates because few monitoring networks for geologic carbon sequestration sites exist. These offered costs represent the author’s ideal envisioned monitoring network and cannot be considered completely applicable to the feasibility of this project.

Table 17 offers associated project costs based off of the available literature related to geologic carbon sequestration monitoring. McCoy and Rubin (2005) base their monitoring costs off of similar monitoring networks related to the transport and storage of petroleum and natural gas products. Costs are broken down into high, average, and low costs. These dollar (\$) per ton of CO₂ costs are based off of transport and storage networks of existing natural gas pipeline networks. High costs reflect scenarios where transport distances are significant and regional topographic barriers require substantial transportation infrastructure. Low costs represent shorter distances across gradual topographic changes. To sequester CO₂ from the Shawville power plant would cost the project between \$13 and \$4 million dollars per year per well in monitoring costs.

Table 17: Associated monitoring costs based of Rubin and McCoy (2005) estimates

McCoy & Rubin (2005)	High Cost (\$/ton)	Average Cost (\$/ton)	Low Cost (\$/ton)
Monitoring Costs	0.10	0.07	0.03
CO ₂ Injected (tons)	3,366,000	3,366,000	3,366,000
Total Costs (\$)	13,348,000	9,440,000	4,040,000

7.6 Conclusions

While a variety of CO₂ monitoring devices exist, each geologic sequestration site has its own unique characteristics and a monitoring network must be tailored to each specific site. Underground reservoir monitoring technologies developed by other industries can be applied to our Rose Run formation injection project, but because other injection projects are still in the pilot program stage, sufficient data is lacking. Each monitoring method has its respective pros and cons and a combination of several monitoring methodologies may prove to best characterize the maturation of carbon dioxide injected reservoirs [7.34]. It appears that monitoring of underground injection reservoirs is possible, however, cost barriers are not fully understood and this may limit the overall viability of successful monitoring for geologic sequestration of carbon dioxide. If we can use already installed monitoring networks, costs can be minimized and monitoring of a Shawville injection project may prove more feasible. Because geologic sequestration is a long-term commitment, public education and awareness will be essential for the vitality of this project. There may be additional incentives from public involvement projects like water quality monitoring, tree planting, or ecosystem surveys. The costs will be burdensome, but monitoring is essential for the long-term sustainability of a Rose Run formation injection project.

Chapter 8: Project Conclusions and Recommendations for Future Work

8.1 Cost Analysis

The following table represents the cost break down for the first ten years of CCS operation within EOR, including all associated costs.

Table 18: Ten year Combined Cost Analysis

VARIOUS COSTS	PER WELL PER YEAR(\$)	TOTAL(MM\$)
Transportation Costs	\$31 million	-310
Capture Costs	0.003264 per scf	-1746.04
Tax Incentives	\$90 years 0-5 \$50 years 5-10	+2408
reworking on existing wells	181968.75(constant for 1 well)	-.6377
operating & maintenance costs	111863.75	-10.06
Co2 recycle cost	700,000Per MMcf/d	-5.13
Co2 recycle O&M cost	1 per Mcf	-.073
Lifting costs	0.3per bbl	-0.12
G&A costs	27965.9.2+0.2*(0.3per bbl)	-2.04
royalties	12.5% of total oil production	-4.57
Income from Oil		+36.59
Monitoring Costs		292.5
total		77.42

After a combined 30 year period, assuming the initial 10 years of EOR and then 20 years of CCS without EOR, the following economic structure of cost is represented in table 19. A discount factor of 4% was considered in this analysis to determine the net present value.

Table 19: 30 year Combined Cost Analysis

VARIOUS COSTS	PER WELL PER YEAR(\$)		TOTAL(MM\$)
Co2 capture cost	. 0.003264per scf	-	-5232.1
Transportation cost	31MM		-930
Tax incentives	\$90 years 0-5 \$50 years 5-10		+2408
Income from Oil Production	-		+36.59
reworking on existing wells	181968.75(constant for 1 well)		-1.64
converting production well into injection well	78391.25(constant for 1 well)		-0.31
operating & maintenance costs	111863.75		-19.02
Co2 recycle cost	700,000Per MMcf/d		-5.131
Co2 recycle O&M cost	1 per Mcf		-0.073
Lifting costs	0.3per bbl		-0.12
G&A costs	27965.9.2+0.2*(0.3per bbl)		-2.03
royalties	12.5% of oil price		-4.57
Monitoring cost	8.7 MM		-552.5
Total			-4,302.90

8.2 Conclusions and Recommendations

After an evaluation of the available technologies and implementation to the Shawville pulverized coal power plant, this study shows that carbon capture and storage is economically feasible with the utilization of enhanced oil recovery and additional bonus incentives from the government, beyond the first ten years, of \$46.87 per ton of CO₂ captured. Current policies and house bills show an increasing effort by both the federal and state governments to establish both an effective carbon cap-and-trade program and laws that provide bonus incentives in the form of carbon credits. It is clear from this study that the support from the government and related agencies is absolutely essential in order to make CCS projects economically feasible. An analysis was performed for the most developed commercial scale carbon capture technology, MEA absorption, and compared with a new and promising technology, CAP. Through literature review and software analysis, the two processes were applied to the Shawville plant and it was determined that MEA absorption is the better, currently available technology on the basis of economics. The process shows an energy penalty of 11.7%, which brings the total thermal efficiency of the power plant down to 20.5%, and an avoided cost of \$57.06 per ton of CO₂ captured.

Hydraulic parameters studied in Midwest Regional Carbon Storage Partnership region (MRCSP) show the Rose Run formation is a suitable storage site. In order to determine the best available injection site for this CCS project, the Ogden and CMU correlation economic models were compared. The annualized total capital costs of these two transportation scenarios yielded significantly different results. Pipeline length is the key parameter for associated transportation costs because of variations in construction and infrastructure capital. Transportation costs can be minimized if CCS technologies are utilized within an enhanced oil recovery paradigm. Our ultimate storage site will be set up after implementation of geologic carbon sequestration within EOR. The potential of CO₂-EOR is globally significant and the United States is poised to benefit from its domestic application. CCS can also be done within EOR to mitigate the greenhouse gas effect of CO₂.

Transportation of CO₂ is a very expensive process. Further research is needed to make transportation cheaper by working on better pipeline networks. As was found in this study, the capture cost is the major contributor to economic viability of the project. Additional research on both pre-combustion, most notably oxy-combustion, and post-combustion technologies needs to be performed in order to bring associated costs down. Also more research on injection well technology (including fracturing for producing more oil in EOR) is necessary to maximize the injection of CO₂ and also make the injection of calcium hydroxide easier and more efficient. In terms of CCS applications, we should try to find ways to enhance mineral trapping over other trapping mechanisms. Collaboration between industry leaders, universities, and government entities is the best option for achieving these goals. Projects will only be accepted by the public if they do not substantially raise electricity prices and are ensured to be safe to the regional environmental health and human safety. Ongoing monitoring at geologic carbon sequestration sites is essential to ensure the sustainability of these carbon capture and storage projects. This study concludes that the application of CCS technologies to the Shawville power plant is only feasible through further economic subsidizes, however, ongoing battles in global politics and public interest in reducing greenhouse gas emissions may encourage a drive towards accepting these expensive technologies.

Appendix A – Capital cost for CO₂ Pipeline Transportation

A1. Parameters

The calculation of compressor and pump power requirements should be based on the following variables using the Ogden Model:

P_{initial} = 435 psia

P_{final} = 2200 psia

P_{cut-off} = 1070 psia

Table 20: Case study input parameters and distributions for the transport models

<i>Parameters</i>	<i>Rep. Value</i>	<i>Distribution</i>
<i>Design CO₂ Mass Flow(Mt/year)</i>	3.4	Uniform
<i>Power Plant Capacity Factor(%)</i>	90%	Uniform
<i>Capital Recovery Factor</i>	0.15/yr	Constant
<i>Pipeline Transport Model Parameters</i>		
<i>Inlet Temperature(°F)</i>	53.6	Constant
<i>Inlet Pressure(pisa)/(Mpa)</i>	2200/15.2	Constant
<i>Outlet Pressure(psia)/(MPa)</i>	1500/10.3	Constant
<i>Total Pipeline Length(ft)</i>	132000/1320000	Uniform
<i>Pipeline Elevation Change(m)</i>	0	Constant

Nomenclature

m = CO₂ mass flow rate to be transported to injection site [tonnes/day]
 P_{initial} = initial pressure of CO₂ directly from capture system [MPa]
 P_{final} = final pressure of CO₂ for pipeline transport [MPa]
 $P_{\text{cut-off}}$ = pressure at which compression switches to pumping [MPa]
 N_{stage} = number of compressor stages [-]
CR = compression ratio of each stage [-]
 $W_{s,i}$ = compression power requirement for each individual stage [kW]
 Z_s = average CO₂ compressibility for each individual stage [-]
 R = gas constant [kJ/kmol-K]
 T_{in} = CO₂ temperature at compressor inlet [K]
 M = molecular weight of CO₂ [kg/kmol]
 η_{is} = isentropic efficiency of compressor [-]
 $k_s = (C_p/C_v)$ = average ratio of specific heats of CO₂ for each individual stage [-]
 $W_{s\text{-total}}$ = total combined compression power requirement for all stages [kW]
 $(W_s)_1$ = compression power requirement for stage 1 [kW]
 $(W_s)_2$ = compression power requirement for stage 2 [kW]

N_{train} = number of parallel compressor trains [-]
 W_p = pumping power requirement [kW]
 ρ = density of CO₂ during pumping [kg/m³]
 η_p = efficiency of pump [-]
 m_{year} = CO₂ mass flow to be transported and stored per year [tonnes/yr]
CF = capacity factor [-]
 m_{train} = CO₂ mass flow rate through each compressor train [kg/s]
 C_{comp} = capital cost of compressor(s) [\$]
 C_{pump} = capital cost of pump [\$]
 C_{total} = total capital cost of compressor(s) and pump [\$]
 C_{annual} = annualized capital cost of compressor(s) and pump [\$/yr]
CRF = capital recovery factor [-/yr]
 C_{lev} = levelized capital costs of compressor(s) and pump [\$/tonne CO₂]
 $O\&M_{\text{annual}}$ = annual O&M costs [\$/yr]
 $O\&M_{\text{factor}}$ = O&M cost factor [-/yr]
 $O\&M_{\text{lev}}$ = levelized O&M costs [\$/tonne CO₂]
 E_{comp} = electric power costs of compressor [\$/yr]
 p_e = price of electricity [\$/kWh]
 E_{pump} = electric power costs of pump [\$/yr]
 E_{annual} = total annual electric power costs of compressor and pump [\$/yr]
 E_{lev} = levelized O&M costs [\$/tonne CO₂]

A2. Calculation of Compressors/Pumps Power Requirements

```
clear;
```

```
clc;
```

```
%%%%%%%%%%%%%%%%%%%%%%%%%%%%%%%%%%%%%%%%%%%%%%%%%%%%%%%%%%%%%%%%%%%%%%%% Compression Power Requirements%%%%%%%%%%%%%%%%%%%%%%%%%%%%%%%%%%%%%%%%%%%%%%%%%%%%%%%%%%%%%%%%%%%%%%%%
```

```

Pinitial=3; %MPa

Pfinal=15.2; %MPa

Pcutoff=7.38; %MPa

Nstage=2;

CR=(Pcutoff/Pinitial)^(1/Nstage); %compression ratio

R=8.314; %KJ/kmol-K

M=44.01; %kg/kmol

Tin=313.15; %K(40C)

nis=0.75; %isentropic effieiciency of compressor

Zs=[0.935;0.845]; %average CO2 compressibility of each individual stage

Ks=[1.379;1.704]; %average ratio of specific hears of CO2 for each individual
stage

m=3.4*10^6*0.9/360; %mass flow rate ton/day

for i=2

    Ws(i)=(1000/24/3600)*(m*Zs(i)*R*Tin/M/nis)*(Ks(i)/(Ks(i)-1))*(CR^((Ks(i)-
1)/Ks(i))-1); %KW%

end

Wstotal=sum(Ws(i)); %KW%

Ntrain=Wstotal/40000; %number of parallel compressor trains

Ntrain=1;

%%%%%%%%%%%%%%%%%%%%%%%%%%%%%%%%%%%%%%%%%%%%%%%%%%%%%%%%%%%%%%%%%%%%%%%%Pupming power requirement for boosting the CO2 pressure

```



```
%%%%%%%%%%%%%%%%%%%%%%%%%%%%%%%%%%%%%%%%%%%%%%%%%%%%%%%%%%%%%%%%%%%%%%%%from Pcutoff(7.38MPa) to Pfinal(15.2MPa)%%%%%%%%%%%%%%%%%%%%%%%%%%%%%%%%%%%%%%%%%%%%%%%%%%%%%%%%%%%%%%%%%%%%%%%%
```

```
r=630; %kg/m^3
```

```
np=0.75; %efficiency of pump
```

```
Wp=(1000*10/24/36)*(m*(Pfinal-Pcutoff)/(r*np));
```

A3. Capital, O&M, and Levelized Costs of CO₂ Compression/Pumping

```
%%%%%%%%%%%%%%%%%%%%%%%%%%%%%%%%%%%%%%%%%%%%%%%%%%%%%%%%%%%%%%%%%%%%%%%%Costs of CO2 compression%%%%%%%%%%%%%%%%%%%%%%%%%%%%%%%%%%%%%%%%%%%%%%%%%%%%%%%%%%%%%%%%%%%%%%%%
```

```
mtrain=(1000*m)/(24*3600*Ntrain); %CO2 mass flow to be transported and stroed  
per year [tonnes/yr]
```

```
Ccomp=mtrain*1*((0.13*10^6)*(mtrain^(-0.71))+(1.4*10^6)*(mtrain)^(-  
0.6)*log(Pcutoff/Pinitial)); %$$
```

```
%%%%%%%%%%%%%%%%%%%%%%%%%%%%%%%%%%%%%%%%%%%%%%%%%%%%%%%%%%%%%%%%%%%%%%%%Costs of CO2 pump%%%%%%%%%%%%%%%%%%%%%%%%%%%%%%%%%%%%%%%%%%%%%%%%%%%%%%%%%%%%%%%%%%%%%%%%
```

```
Cpump=(1.11*10^6)*(Wp/1000)+0.07*10^6;
```

```
%%%%%%%%%%%%%%%%%%%%%%%%%%%%%%%%%%%%%%%%%%%%%%%%%%%%%%%%%%%%%%%%%%%%%%%%Total capital costs%%%%%%%%%%%%%%%%%%%%%%%%%%%%%%%%%%%%%%%%%%%%%%%%%%%%%%%%%%%%%%%%%%%%%%%%
```

```
Ctotal=Ccomp+Cpump;
```

```
CRF=0.15; %capital recovery factor
```

```
Cannual=Ctotal*CRF;
```

```
CF=0.9; %capacity factor
```

```
myear=m*360;
```

```
%%%%%%%%%%%%%%%%%%%%%%%%%%%%%%%%%%%%%%%%%%%%%%%%%%%%%%%%%%%%%%%%%%%%%%%%Levelized capital costs(Clev)%%%%%%%%%%%%%%%%%%%%%%%%%%%%%%%%%%%%%%%%%%%%%%%%%%%%%%%%%%%%%%%%%%%%%%%%
```

```
Clev=Cannual/myear;
```

%%The annual operation and maintenances

%%costs (OM) annual%%

OMfactor=0.04;

OMannual=Ctotal*OMfactor;

%%Levelized O&M cost%%

OMlev=OMannual/myear;

%%Total electric power costs of compressors (Ecomp) and

%%pump (Epump) %%%

Pe=0.065; %electricity price \$0.065/kWh

Eannual=Pe*(Wstotal+Wp)*(CF*24*360);

Elev=Eannual/myear;

%%Total annual and levelized costs of CO2

%%compression/pumping%%

Tannual=Cannual+OMannual+Eannual;

Tlev=Clev+OMlev+Elev;

A.4 Determine the Diameter of Pipeline

It is assumed that the transportation distance for the Colfax Field is 1320000ft(250 miles) away from the Shawville plant and underlying storage radius is 132000ft(25 miles). It's a 572MW coal plant with CO₂ emission of 3.4 million tons/year and the capital factor is 0.9. Since the calculation of pipeline diameter is an iterative process, one must first guess a value for diameter (D). A reasonable first approximation is D=10inches.

An estimation of the density (ρ) and viscosity (μ) of CO₂ in the pipeline (approximated at T and Pinter) is also required. We choose to use [4.12] to get approximation values. The Reynold's number (Re) and Fanning friction factor (Ff) for CO₂ fluid flow in the pipeline are calculated by the following equations from [4.13]

```
clear;

clc;

Pin=15.2; %Pipeline inlet pressure MPa
Pout=10.3; %Pipeline outlet pressure

Pave=2/3*(Pout+Pin-Pout*Pin/(Pout+Pin));

D=10; %Initial guess of pipeline diameter
delP=Pin-Pout;

L=400; %pipeline length km
m=8500; %mass flow rate tonns/day
v=1.06*10^(-4); %viscosity
d=930.56; %km/m^3
e=0.00015; %roughness in ft

del=10;

while del>=0.01

Re=(4*1000/24/3600/0.0254)*m/(pi*v*D);

Ff=1/(4*(-1.8*log10(6.91/Re+(12*(e/D)/3.7)^1.11))^2);
```

```

Dnew=(1/0.0254) * ((32*Ff*m^2) * (1000/24/3600)^2 / (pi^2*d*(delP/L) *10^6/1000))^(1/5);

del=Dnew-D;

D=Dnew;

end

```

A.5 Pipeline Transportation cost

```

clear;

clc;

%%%%%%%%%%CMU Correlation%%%%%%%%%%

m=8500;

b=42404;

D=16; %inches

x=1.035;

L=217.5; %miles

y=0.853;

z=1.516; %region weights

LCC=b*D^x*L^y*z;

OM=5000; %$5000/mile

OMcost=5000*L;

CRF=0.15;

Annualized=LCC*CRF+OMcost;

myear=m*360;

LC=Annualized/myear;

```

APPENDIX B – EOR Calculations

B.1 Various costs involved in EOR process

These cost formulas have been taken from case studies of CO₂-EOR in Illinois and Michigan basin in 2004. In order to make them relevant for 2011, we add 25% extra in each cost.

1. Cost of Converting Existing Production Wells into Injection Wells.

$$\text{Well Conversion Costs} = c_0 + c_1D$$

$$\text{Where: } c_0 = \$10,438 \text{ (fixed)}$$

$$c_1 = \$6.97 \text{ per foot}$$

$$\text{final Well Conversion Costs} = 1.25 * (c_0 + c_1D)$$

2. Costs of Reworking an Existing Waterflood Production or Injection Well for CO₂-EOR (First Rework).

$$\text{Well Rework Costs} = c_1D$$

$$\text{Where: } c_1 = \$19.41 \text{ per foot}$$

$$D \text{ is well depth}$$

$$\text{Final cost} = 1.25 * (c_1D)$$

3. Annual O&M Costs, Including Periodic Well Workovers.

$$\text{Well O\&M Costs} = b_0 + b_1D$$

$$\text{Where: } b_0 = \$24,166 \text{ (fixed)}$$

$$b_1 = \$8.71 \text{ per foot}$$

$$D \text{ is well depth}$$

$$\text{Final cost} = 1.25(b_0 + b_1D)$$

4. Carbon dioxide Recycle Plant Investment:

The cost of the recycling plant is set at \$700,000 per MMcf/d of CO₂ capacity.

5. Carbon dioxide Recycle O&M Costs.

\$0.25 per Mcf @ \$25 Bbl oil.

6. Lifting Costs: \$0.25 per barrel.

7. G&A Costs: 20% of well O & M and lifting costs

8. Royalties: Royalty payments are assumed to be 12.5%.

B.2 Calculation of Original Oil in Place (OOIP) In Coalfax Field

$$N=(7758\text{bbls}/\text{Ac}\cdot\text{ft})Ah\phi(1-S_{wc})/B_{oi}$$

Where

N =Original oil in place(STB)

A = Drainage area(Acre) =130Acre

h = thickness(ft) = 26.6-27ft

ϕ = porosity = 17.1%

S_{wc} = connate water saturation =41.8%

B_{oi} = initial oil formation factor (rb/STB)=1.17-1.21

$$N=(7758*130*27*0.171*0.582)/1.21 \text{ to } (7758*130*26.6*0.171*0.582)/1.17$$

$$N=2239.7 \text{ MSTB to } 2281.95 \text{ MSTB}$$

Appendix C – CCS Monitoring

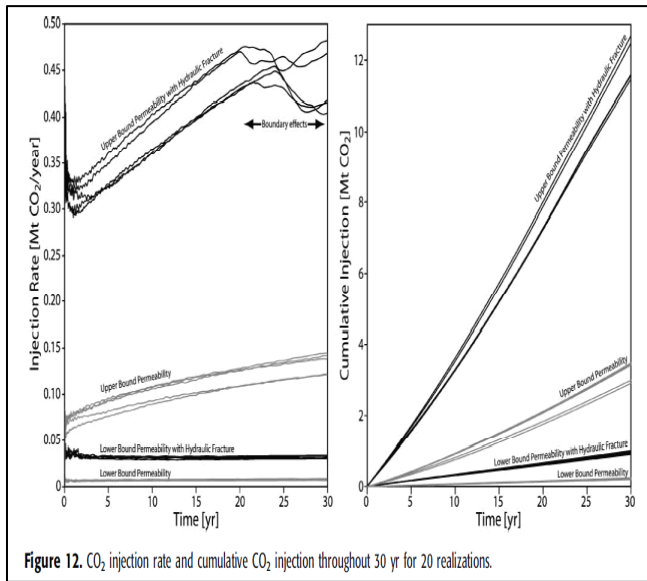

Figure 46: Hypothetical injection rates (Mt CO₂/year) in Rose Run Formation. [7.35]

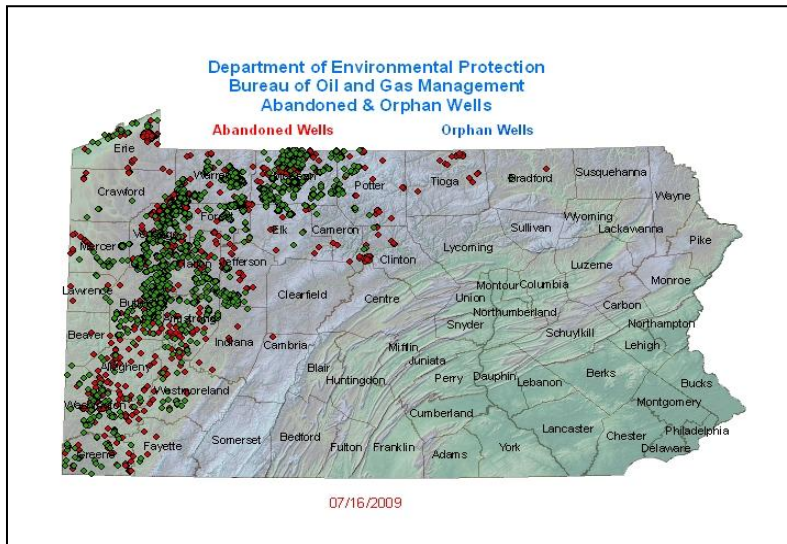

Figure 47: Abandoned oil and natural gas well in Pennsylvania [7.43]

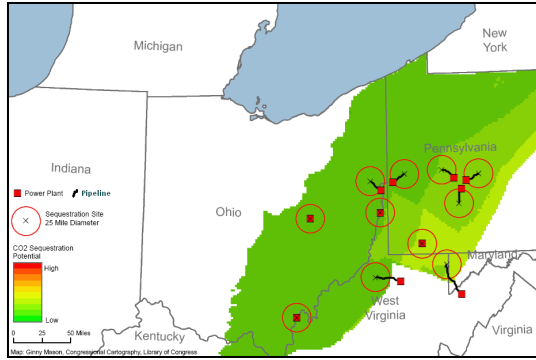

Figure 48: Hypothetical CO₂ pipelines to Rose Run formation. [7.36]

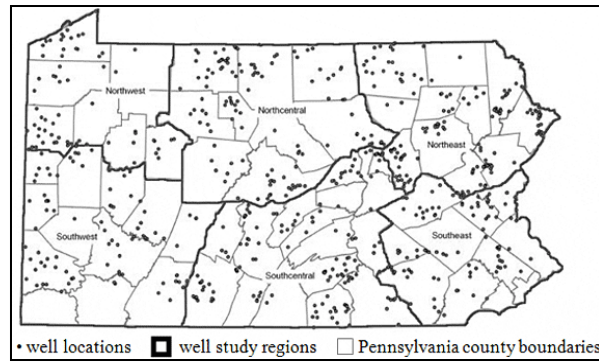

Figure 49: Pennsylvania Department of Environmental Protection Water Monitoring Network [7.44]

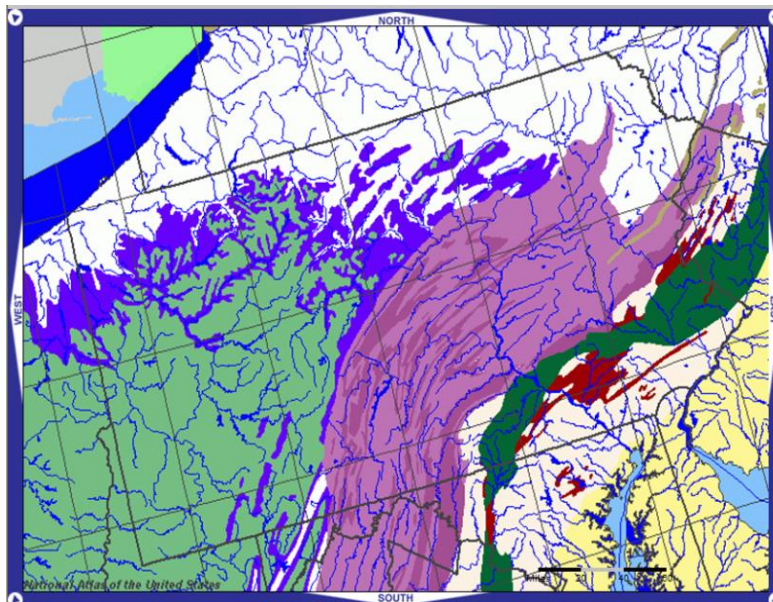

Figure 50: Major aquifers in Pennsylvania

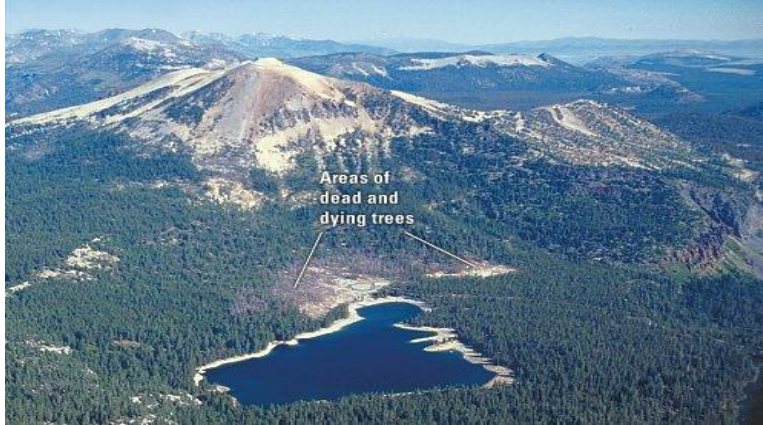

Figure 51: kill at Mammoth Mountain from CO₂ fumaroles [7.45].

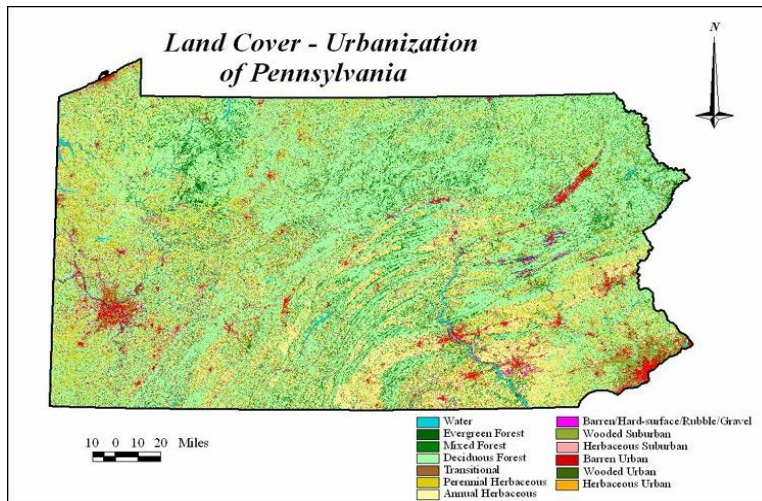

Figure 52: Land cover of Pennsylvania [7.46].

Works Cited

- [1.1] Carbon Sequestration Technology Roadmap and Program Plan (2007), Department of Energy (DOE) & National Energy Technology Laboratory (NETL), www.netl.doe.gov
- [2.1] CO₂ Capture and Geological Storage In Depth, Some key principles for policymakers (May 2008), *CO₂ Capture Project*, <http://www.co2captureproject.org/>
- [2.2] Carbon Capture and Sequestration: Framing the Issues for Regulations, An Interim Report from the CCSReg Project, (January 2009), *CCSReg*, http://www.ccsreg.org/policy_briefs.html
- [2.3] Pennsylvania Final Climate Change Action Plan (December 2009), *Pennsylvania Department of Environmental Protection (DEP)*, <http://www.dep.state.pa.us/>
- [2.4] Carbon Sequestration Technology Roadmap and Program Plan (2007), Department of Energy (DOE) & National Energy Technology Laboratory (NETL), <http://www.netl.doe.gov>
- [2.5] Cap and trade vs. Pa.: We can protect the environment without losing thousands of jobs (November 06, 2009), Pat Toomey, *Pittsburgh Post-Gazette*, <http://www.post-gazette.com/pg/09310/1011153-109.stm#ixzz0hHmliWzm>
- [2.6] *DiFrancesco, Nick*. Pennsylvania will suffer with cap-and-trade bill (December 2009). *Central Penn Business Journal*
- [2.7] Cap-and-Trade Bill Bad for Pennsylvania Workers and Families (June 26th), *Jim Gerlach, Congressman*, <http://gerlach.house.gov/news/DocumentSingle.aspx?DocumentID=134824>
- [2.8] Current and Near-Term Greenhouse Gas Reduction Initiatives, *Environmental Protection Agency (EPA)*, <http://www.epa.gov/climatechange/policy/neartermghgreduction.html>
- [2.9] Environmentalists hail Supreme Court ruling on carbon (April 3, 2007), *Linda Greenhouse, The New York Times*, http://www.nytimes.com/2007/04/03/world/americas/03iht-scotus.1.5124385.html?_r=2&pagewanted=
- [2.10] The Future of Energy (April 2010), *U.S. NEWS & WORLD REPORT, REALITY CHECK: The Powers That Be*
- [2.11] Carbon Capture & Sequestration within House Bill 80, *PennEnvironment*, <http://www.pennenvironment.org/legislature/testimony/oceans-testimony/global-warming/carbon-capture--sequestration-within-house-bill-80>
- [2.12] Summary of the Dingell-Boucher Discussion Draft, *Pew Center on Global Climate Change*, <http://www.pewclimate.org/docUploads/Dingell-BoucherSummary.pdf>
- [2.13] *Massachusetts v. Environmental Protection Agency*, 549 U.S. 497 (2007), Supreme Court, http://en.wikipedia.org/wiki/Massachusetts_v._Environmental_Protection_Agency

- [3.1] NETL Coal Plant Database, 2007. Available from <http://www.netl.doe.gov/energy-analyses/pubs/database/>.
- [3.2] Davidson, J and Thambimuthu, K. *An overview of technologies and costs of carbon dioxide capture in power generation*. J. Power and Energy, 2009.
- [3.3] Figueroa, J et al. *Advances in CO2 capture technology – The U.S. Department of Energy’s Carbon Sequestration Program*. International Journal of Greenhouse Gas Control 2, (2008) 9-20.
- [3.4] Sherrick, Brian et al. *CCS with Alstom’s Chilled Ammonia Process at AEP’s Mountaineer Plant*. Paper No. 167, Alstom, 2008.
- [3.5] Black, Sean. *Chilled Ammonia Process for CO2 Capture*. PT/PE Sector Communications. Alstom, 2006.
- [3.6] Jones, C. W. et al. *Adsorbent Materials for Carbon Dioxide Capture from Large Anthropogenic Point Sources*. ChemSusChem 2009, 2, 796-854.
- [3.7] DOE/NETL. *Carbon Dioxide Capture from Existing Coal-Fired Power Plants*. DOE/NETL-401/110907. November 2007.
- [3.8] EPA, 2003. *Air Pollution Control Technology Fact Sheet: Flue Gas Desulfurization*. US Environmental Protection Agency, CICA. EPA-452/F-03-034.
- [4.1] The Midwest regional Carbon Sequestration Partnership(MRCSP) Phase I Final Report, Period of Performance: October 2003-September 2005, Submitted by Battelle, DOE Cooperative Agreement No:DE-FC26-03NT41981
- [4.2] The Midwest regional Carbon Sequestration Partnership(MRCSP) Phase I Stand Alone Executive Summary, Period of Performance: October 2003-September2005, Submitted by Battelle, DOE Cooperative Agreement No:DE-FC26-03NT41981
- [4.3]MidwestRegionalCarbonSequestrationPartnership[[http://www.netl.doe.gov/technologies/carbon_seq/refshelf/atlas/Midwest Regional Carbon Sequestration Parternship.pdf](http://www.netl.doe.gov/technologies/carbon_seq/refshelf/atlas/Midwest%20Regional%20Carbon%20Sequestration%20Partnership.pdf)]
- [4.4]Neeraj Gupta, June 2008, The Ohio River Valley CO2 Storage Project AEP Mountaineer Plant, West Virginia Final Technical Report, Battelle Memorial Institute, U.S. Department of Energy National Energy Technology Laboratory, Contract No. DE-AC26-98FT40418
- [4.5] Neeraj Gupta, August 2003, Interim Topical Report The Ohio River Valley CO2 storage Project Preliminary Geologic Assessment Report Battelle, Period of Performance: June 2002-May 2003
- [4.6]Paul W. Parfomak and Peter Folger, January 10,2008, Pipelines for Carbon Di oxide(CO2) Control: Network Needs and Cost Uncertainties, Order Code RL34316
- [4.7] Denbury Resources Inc., “EOR: The Economic Alternative for CCS,” Slide presentation (October 2007).[http://www.gasification.org/Docs/2007_Papers/25EVAN.pdf];U.S.Dept.ofTransportation,

National Pipeline Mapping System, Official use only. (June 2005). [https://www.npms.phmsa.dot.gov]

- [4.8] R.T. Dahowski, J.J. Dooley, C.L. Davidson, S. Bachu, N. Gupta, and J. Gale, "A North American CO₂ Storage Supply Curve: Key Findings and Implications for the Cost of CCS Deployment," *Proceedings of the Fourth Annual Conference on Carbon Capture and Sequestration* (Alexandria, VA: May 2-5, 2005)
- [4.9] Jennie C. Stevens and Bob Van Der Zwaan, "The Case for Carbon Capture and Storage," *Issues in Science and Technology*, vol. XXII, no. 1 (Fall 2005): 69-76. (See page 15 of this report for a discussion of safety issues.)
- [4.10] Paul W. Parfomak, Peter Folger, January 17, 2008, Carbon Dioxide (CO₂) Pipelines for Carbon Sequestration: Emerging Policy Issues. Order Code RL33971
- [4.11] Farris, C.B., 1983. Unusual design factors for supercritical CO₂ pipelines. *Energy Prog.* 3 (3), 150–158.
- [4.12] Mohitpour, M., Golshan, H., Murray, A., 2003. In: *Pipeline Design & Construction*. first ed. ASME Press, New York, NY.
- [4.13] David L. McCollum, Techno-Economic Models for Carbon Dioxide Compression, Transport, and Storage & Correlations for Estimating Carbon Dioxide Density and Viscosity
- [4.14] Herzog, Heddle, and Klett, "The Economics of CO₂ Storage", MIT Laboratory for Energy and the Environment, Pub. # LFEE 2003-003 RP (August 2003).
- [4.13] Herzog, Heddle, and Klett, "The Economics of CO₂ Storage", MIT Laboratory for Energy and the Environment, Pub. # LFEE 2003-003 RP (August 2003).
- [5.1] B. Saylor, G. Matisoff, P. Morrison. Geologic and Geochemical Evaluation of the Potential for CO₂ Disposal in Deep Saline Aquifers Beneath Ohio.
- [5.2] The Colfax Field Rose Run: A Reservoir Study, D.C. Freeman, Marietta College; J.R. Blomberg, Blomberg Engineering; J.J. Tardivo, ChevronTexaco; T.S. Knobloch, J.J. James, James Engineering, Inc.
- [5.3] M. Loizzo, SPE, B. Lecampion, SPE, T. Bérard, A. Harichandran, and L. Jammes. Reusing O&G Depleted Reservoirs for CO₂ Storage: Pros and Cons, Schlumberger Carbon Services
- [5.4] Y. Soong*, J. R. Jones, D. K. Harrison, S. W. Hedges, A. L. Goodman, and J. P. Baltrus. Mineral Trapping of CO₂ with Oriskany Brine. U.S. Department of Energy, National Energy Technology Laboratory,
- [5.5] McGrail BP, PF Martin, KP Saripalli, SL Bryant, and BM Sass. 2001. "Use of Forced Mineral Trapping for Sequestration of CO₂." In First National Conference on Carbon Sequestration. National

Energy Technology Laboratory, Morgantown, WV. 6.1 Source:Enhanced Oil Scoping Study Tr113836 Final Report October 1999

- [6.2] F.M. ORR, JR., J.P. Heller and J.J. Taber, Carbon Dioxide Flooding for Enhanced Oil Recovery: Promise and Problems, New Mexico Petroleum Recovery Research Center, (<http://www.springerlink.com/content/g691l73n42665170/fulltext.pdf>)
- [6.3] Biniam Zerai *, Beverly Z. Saylor, Gerald Matisoff. Computer simulation of CO₂ trapped through mineral precipitation in the Rose Run Sandstone.,
- [6.4] Summary of Carbon Dioxide Enhanced Oil Recovery (CO₂EOR) Injection Well Technology Supporting Information Provided by James P. Meyer PhD Contek Solutions 2828 West Parker Rd., Suite 102-B Plano, Texas 75075
- [6.5] Adel M. Elsharkawy*. Measuring CO₂ Minimum Miscibility Pressures: Slim-Tube or Rising-Bubble Method?
- [6.6] Basin oriented strategies for enhanced oil recovery: Illinois and Michigan basins. Prepared for U.S Dept. of Energy, Office of Fossil Energy-Office of Oil & Natural Gas
- [6.7] Design Engineering of Energy and Geo-Environmental Systems Capture, sequestration, and Utilization of carbon dioxide From power generation plant(Spring 2009, EGEE-580)
- [7.1] McCoy, S.T. and Rubin, E.S. 2008. An engineering-economic model of pipeline transport of CO₂ with application to carbon capture and storage. International Journal of Greenhouse Gas Control. 219-229.
- [7.2] Benson, S.M. and Cole, D.R. 2008. CO₂ sequestration in deep sedimentary formations. Elements. Vol. 4. 325-331.
- [7.3] Essandoh-Yeddu, J. and Gulen, G. 2008. Economic modeling of carbon dioxide integrated pipeline network for enhanced oil recovery and geologic sequestration in Texas Gulf Coast region: presented at the 9th International Conference on Greenhouse Gas Control Technologies (GHGT-9), Washington, D.C. GCCC Digital Publication Series #08-03k.
- [7.4] Lucier, A., Zoback, M., Gupta, N., and Ramakrishnan, T.S. 2006. Geomechanical aspects of CO₂ sequestration in a deep saline reservoir in the Ohio River Valley region. *Environmental Geosciences*. **13**:2 85-103.
- [7.5] Benson, S.M. and Cole, D.R. 2008. CO₂ sequestration in deep sedimentary formations. Elements. Vol. 4. 325-331.
- [7.6] Lucier, A., Zoback, M., Gupta, N., and Ramakrishnan, T.S. 2006. Geomechanical aspects of CO₂ sequestration in a deep saline reservoir in the Ohio River Valley region. *Environmental Geosciences*. **13**:2 85-103.

- [7.7] Perrin, J. Krause, M., Kuo, W., Miljkovic, L., Charoba, E., and Benson, S. 2009. Core-scale experimental study of relative permeability properties of CO₂ and brine in reservoir rocks. *Energy Procedia*. 3512-3522.
- [7.8] Benson, S. and Meyer, L. 2002. "Monitoring to Ensure Safe and Effective Geologic Storage of Carbon Dioxide," Intergovernmental Panel on Climate Change (IPCC) Workshop on Carbon Sequestration, November 18-22, 2002, Regina, Saskatchewan, Canada.
- [7.9] Benson, S.M., R. Hepple, J. Apps, C.F. Tsang, and M. Lippmann (2002a): Lessons Learned from Natural and Industrial Analogues for Storage of Carbon Dioxide in Deep Geologic Formations, *Lawrence Berkeley National Laboratory Report LBNL-51170*.
- [7.10] Brown, G. A. and A. Hartog (2002): Optical Fiber Sensors in Upstream, Oil and Gas, *Society of Petroleum Engineers*. **11** 63-65.
- [7.11] Brown, G. A. and A. Hartog (2002): Optical Fiber Sensors in Upstream, Oil and Gas, *Society of Petroleum Engineers*. **11** 63-65.
- [7.12] Wainner, R.T., Frish, M.B., Green, D., Laderer, M.C., Allen, M.G., and Morency, J.R. 2007. High Altitude Aerial Natural Gas Leak Detection System. Physical Sciences Inc. Contract No. DE-FC26-04NT42268. http://www.netl.doe.gov/technologies/oil-gas/publications/td/NT42268_FinalRpt.PDF
- [7.13] Parfomak, P.W. and Folger, P. 2008. CRSReportRL33971, Carbon Dioxide(CO₂) Pipelines for Carbon Sequestration: Emerging Policy. Issues 5.
- [7.14] Strutt, M.H., S.E. Beaubien, J.C. Baubron, M. Brach, C. Cardellini, R. Granieri, D.G. Jones, S. Lombardi, L. Penner, F. Quattrocchi, and N. Voltattorni (2002): Soil Gas as a Monitoring Tool of Deep Geological Sequestration of Carbon Dioxide: Preliminary Results from the Encana EOR Project in Weyburn, Saskatchewan (Canada), Sixth International Conference on Greenhouse Gas Control Technologies (GHGT-6), Kyoto, Japan.
- [7.15] Benson, S. and Meyer, L. 2002. "Monitoring to Ensure Safe and Effective Geologic Storage of Carbon Dioxide," Intergovernmental Panel on Climate Change (IPCC) Workshop on Carbon Sequestration, November 18-22, 2002, Regina, Saskatchewan, Canada.
- [7.16] LI-COR, Inc., website, home, www.licor.com/, LI-COR environmental home page, <http://env.licor.com/>, information on gas analyzers, <http://env.licor.com/products/gas.htm>, 2001.
- [7.17] Sorrey, M.L., C.D. Farrar, W.C. Evans, D.P. Hill, R.A. Bailey, J.W. Hendley II, and P.H. Stauffer (1996): Invisible CO₂ Gas Killing Trees at Mammoth Mountain, California, *U.S. Geological Survey Fact Sheet*, pp. 172-196, <http://wrgis.wr.usgs.gov/fact-sheet/fs172-96/>, [http://quake.wr.usgs.gov/prepare/factsheets/CO₂/](http://quake.wr.usgs.gov/prepare/factsheets/CO2/).

- [7.18] Benson, S. and Meyer, L. 2002. "Monitoring to Ensure Safe and Effective Geologic Storage of Carbon Dioxide," Intergovernmental Panel on Climate Change (IPCC) Workshop on Carbon Sequestration, November 18-22, 2002, Regina, Saskatchewan, Canada.
- [7.19] Benson, S. and Meyer, L. 2002. "Monitoring to Ensure Safe and Effective Geologic Storage of Carbon Dioxide," Intergovernmental Panel on Climate Change (IPCC) Workshop on Carbon Sequestration, November 18-22, 2002, Regina, Saskatchewan, Canada.
- [7.20] Benson, S.M. and Cole, D.R. 2008. CO₂ sequestration in deep sedimentary formations. *Elements*. Vol. 4. 325-331.
- [7.21] Zhang, Y., Oldenburg, C.M., and Benson, S.M. 2004. Vadose zone remediation of carbon dioxide leakage from geologic carbon dioxide sequestration sites. *Vadose Zone Journal*. Vol. 3. 858-866.
- [7.22] Gunter, W.D., R.J. Chalaturnyk, and J.D. Scott (1998): Monitoring of Aquifer Disposal of CO₂: Experience from Underground Gas Storage and Enhanced Oil Recovery, *Proceedings of GHGT-4*, Interlaken, Switzerland. 151-156.
- [7.23] Emberley, S., I. Hutcheon, M. Shevalier, K. Durocher, W.D. Gunter, and E.H. Perkins (2002): Geochemical Monitoring of Fluid-Rock Interaction and CO₂ Storage at the Weyburn CO₂ Injection Enhance Oil Recovery Site, Saskatchewan, Canada, Sixth International Conference on Greenhouse Gas Control Technologies (GHGT-6), Kyoto, Japan, 1-4 October, 2002.
- [7.24] Benson, S.M., R. Hepple, J. Apps, C.F. Tsang, and M. Lippmann (2002a): Lessons Learned from Natural and Industrial Analogues for Storage of Carbon Dioxide in Deep Geologic Formations, *Lawrence Berkeley National Laboratory Report LBNL-51170*.
- [7.25] Sato, K., Mito, B., Horie, T., Ohkuma, H., Saito, H., Watanabe, J. and Yoshimura, T. 2009. A monitoring framework for assessing underground migration and containment of carbon dioxide sequestered in an onshore aquifer. *Energy Procedia*. 2261-2268.
- [7.26] Benson, S.M. and Cole, D.R. 2008. CO₂ sequestration in deep sedimentary formations. *Elements*. Vol. 4. 325-331.
- [7.27] Onuma, T. and Ohkawa, S. 2008. Detection of surface deformation related with CO₂ injection by DInSAR at in Salah, Algeria. *Energy Procedia*. 1-8.
- [7.28] Arts, R., O. Eiken, A. Chadwick, P. Zweigel, L. van der Meer, and B. Zinszner (2002): Monitoring of CO₂ Injected at Sleipner Using Time Lapse Seismic Data, Sixth International Conference on Greenhouse Gas Control Technologies (GHGT-6), Kyoto, Japan, 1-4 October, 2002.
- [7.29] Parfomak, P.W. and Folger, P. 2008. CRSReportRL33971, Carbon Dioxide(CO₂) Pipelines for Carbon Sequestration: Emerging Policy. Issues 5.

- [7.30] Zheng, L., Apps, J.A., Zhang, Y., Xu, Tianfu, X. and Birkholzer, J.T. 2009. On mobilization of lead and arsenic in groundwater in response to CO₂ leakage from deep geological storage. *Chemical Geology*. **268** 218-297.
- [7.31] Tarkowski, R., Krolik, W., Uliasz-Misiak, and Barabasz, W. 2002. Biomonitoring as a tool to detect CO₂ leakage from underground storage. Mineral and Energy Economy Research Institute of Polish Academy of Sciences. <http://www.minpan.krakow.pl/zaklady/tark/biomonitoring.pdf>
- [7.32] Sorrey, M.L., C.D. Farrar, W.C. Evans, D.P. Hill, R.A. Bailey, J.W. Hendley II, and P.H. Stauffer (1996): Invisible CO₂ Gas Killing Trees at Mammoth Mountain, California, *U.S. Geological Survey Fact Sheet*, pp. 172-196, <http://wrgis.wr.usgs.gov/fact-sheet/fs172-96/>
- [7.33] Tarkowski, R., Krolik, W., Uliasz-Misiak, and Barabasz, W. 2002. Biomonitoring as a tool to detect CO₂ leakage from underground storage. Mineral and Energy Economy Research Institute of Polish Academy of Sciences. <http://www.minpan.krakow.pl/zaklady/tark/biomonitoring.pdf>
- [7.34] Zhang, Y., Oldenburg, C.M., and Benson, S.M. 2004. Vadose zone remediation of carbon dioxide leakage from geologic carbon dioxide sequestration sites. *Vadose Zone Journal*. Vol. 3. 858-866.
- [7.35] Lucier, A., Zoback, M., Gupta, N., and Ramakrishnan, T.S. 2006. Geomechanical aspects of CO₂ sequestration in a deep saline reservoir in the Ohio River Valley region. *Environmental Geosciences*. **13**:2 85-103.
- [7.36] Parfomak, P.W. and Folger, P. 2008. CRSReportRL33971, Carbon Dioxide(CO₂) Pipelines for Carbon Sequestration: Emerging Policy. Issues 5.
- [7.37] Price, P.N, McKone, T.E., and Sohn, M.D. Carbon sequestration risks and Risk Management. 2004. Lawrence Berkeley National Laboratory. LBNL-513E
- [7.38] Boland, S., Bosch, H., Brown, L., Burrows, J., Ciais, P., Connor, B. *et al.* 2009. The need for atmospheric carbon dioxide measurements from space: contributions from a rapid reflight of the Orbiting Carbon Observatory. NASA. September 16, 2009.
- [7.39] JAXA. 2010. Public release of concentration data (carbon dioxide and methane) analyzed from GOSAT observation data. National Institute for Environmental Studies. http://www.gosat.nies.go.jp/eng/result/download/GOSAT_20100216_en.pdf
- [7.40] Pennsylvania Department of Conservation and Natural Resources. *What can I do?* http://www.dcnr.state.pa.us/forestry/gypsomoth/gm_whatcanido.aspx (Accessed 4/16/2010)
- [7.41] Asner, G.P., 2009, Tropical forest carbon assessment: integrating satellite and airborne mapping approaches. *Environ. Res. Lett.* 4
- [7.42] Thompson, D. 2002. Economic aspects of growing hardwood plantations on farms in the New England region. Northwest Forestry Investment group. 1-6.

- [7.43] Pennsylvania Department of Environmental Protection. *Abandoned and Orphan Well Program*. <http://www.dep.state.pa.us/dep/deputate/minres/oilgas/abandonedOrphan.htm> (Accessed 4/19/2010)
- [7.44] PA DEP. *Well Monitoring Network*. http://www.depweb.state.pa.us/portal/server.pt/community/dep_home/5968 (Accessed 4/19/2010)
- [7.45] United States Geological Survey. www.usgs.gov (Accessed 4/20/2010)
- [7.46] Pennsylvania Department of Conservation and Natural Resources. *Pennsylvania habitats*. <http://www.dcnr.state.pa.us/wlhabitat/pahabitats.aspx> (Accessed 4/22/2010)