

EME-580 INTEGRATIVE DESIGN

PLASMA GASIFICATION FOR VOC DESTRUCTION

By

Amrita Mukherjee
Chethan K Gaddam
Debanjan Das
Ganesh R Bhimanapati

Faculty

Dr. Larry Grayson
Professor of Energy and Mineral Engineering
Dr. Derek Elsworth
Professor of Energy and Geo-Environmental Engineering



DEPARTMENT OF ENERGY & MINERAL ENGINEERING
COLLEGE OF EARTH & MINERAL SCIENCES
THE PENNSYLVANIA STATE UNIVERSITY
HOSLER BUILDING, UNIVERSITY PARK, PA-16802

Table of Contents

1. Introduction.....	7
1.1 Overview.....	7
2.2 Problem Statement.....	8
2. Background & Literature Review.....	9
2.1 Volatile Organic Compounds (VOC)-A critical Issue.....	9
2.2 Plasma Background Concept.....	10
2.3 The Process.....	12
2.4 Pollution Control-Conventional Method.....	13
2.5 Motivation for a non-thermal plasma system for VOC removal.....	16
3. Chemistry.....	18
3.1 Reaction Mechanism.....	18
3.2 Plasma Chemistry & Destruction Mechanism.....	24
3.3 Electron Impact processes.....	26
3.4 Case Study.....	27
4. Literature review for Reactor Design & Catalyst.....	34
4.1 Reactor Design.....	34
4.2 Comparison of Reactors.....	40
4.3 Catalyst.....	43

5. Final Reactor Design.....	55
5.1 Design Modification.....	55
5.2 Scale-up Calculations.....	56
5.3 Plant Lay-out.....	58
5.4 Electrical System.....	59
6. Energy Economics & Analysis.....	61
6.1 Cost Effectiveness & Optimization.....	61
6.2 Figures of Merit.....	62
6.3 Detailed cost estimate & analysis of entire system.....	64
6.4 Operating Cost.....	66
6.5 Comparative study of NTP & RTO.....	67
6.6 Sensitivity Analysis.....	68
7. Conclusion.....	75
8. References.....	77

List of Figures

Figure 1 Pennsylvania VOC Emissions	6
Figure 2. Different forms of non-thermal plasma	11
Figure 3. Comparison of four states of matter	12
Figure 4. Dielectric barrier discharge (DBD)	13
Figure 5. A typical thermal incinerator used for VOC destruction	15
Figure 6. Timescale events of elementary processes in a non-thermal process	19
Figure 7. Reaction pathways of radicals	23
Figure 8. Decomposition rate of toluene.....	31
Figure 9. Optical emission spectrum of Toluene	32
Figure 10. Pulsed corona discharge	34
Figure 11. . Dielectric Barrier Discharge schematic diagram, DBD generating plasma	35
Figure 12. Annular Plasma reactor	37
Figure 13. Rectangular plasma reactor	37
Figure 14. Modified rectangular plasma	37
Figure 15. Gliding Arc.....	38
Figure 16. Packed Bed Reactor.....	39
Figure 17. Plasma Driven Catalysis.....	39
Figure 18. Specific Input Energy Comparision.....	40
Figure 19. Comparison of aerosol formation in reactors	41
Figure 20. CO2 selectivity	41
Figure 21. Basic Design of the Reactor	42
Figure 22. Packed Bed Reactor.....	44

Figure 23. Single stage plasma catalytic reactor	45
Figure 24. Illustration of performance of SPC and corresponding effects on the performance.....	45
Figure 25. Two Stage Plasma System	46
Figure 26. Different types of packing of catalyst (a)only BaTiO ₃ ,(b) BaTiO ₃ +Catalyst Al ₂ O ₃ (c) BaTiO ₃ + Catalyst Al ₂ O ₃ (Alumina big)	48
Figure 27 (a) Only ferroelectric materials, (b) Catalyst articles<Ferroelectric particles, (c) Catalyst particles>Ferroelectric particles.....	49
Figure 28 Graph showing conversion Vs Specific Energy Density.....	50
Figure 29 Conversion Vs SED.....	51
Figure 30. Conc. Levels of Benzene and COx over time in the reactor	51
Figure 31. Levels of COx with plasma and with plasma + catalyst.....	52
Figure 32. Catalytic reactor.....	56
Figure 33. Proposed design.....	58
Figure 34. Effluent plant layout	58
Figure 35. Electrical system of Plasma unit.....	59
Figure 36. Voltage and Current Measuring Circuit	60
Figure 37. Total Annual Cost Comparison of Control Techniques	67
Figure 38. Removal Cost per Unit Contaminant at 2000 L/min and 2000 ppm	68
Figure 39. Sensitivity Analysis.	70
Figure 40. Sensitivity Analysis	70
Figure 41. Sensitivity Analysis.	71
Figure 42. Sensitivity Analysis	72
Figure 43. Voltage-Current curves.....	72
Figure 44. I-V Curves	73

List of Tables

Table 1. Energy cost (EC) and G-value required for the formation of reactive species.	20
Table 2 Oklahoma Tinker Base VOC Emissions.....	28
Table 3. Showing Various Catalysts Used for Various VOC's And Their Introduction in the System	53
Table 4. Capital cost	64
Table 5. Capital cost for piping.....	65
Table 6. Capital cost	65
Table 7. Capital cost for sensors and spectrometers	66

Chapter 1

Introduction

1.1 Overview

In the last century rapid industrialization has led to a lot of amazing things which has helped mankind in every way but it has also raised some points of concern which need to be addressed with immediate effect. One of the main issues is the increasing amount of volatile organic compounds which is emitted from the effluents of any typical process and manufacturing industries. Traditional techniques such as thermal incinerators and recuperative oxidizers have proved to be very effective but they don't come without some shortcomings which primarily include high operating and capital cost with bulky and large equipment size. The usage of liquid and gaseous fuels including natural gas in running the incinerators on a continuous plant operation basis is also one of the drawbacks of this system.

Due to the fact that VOCs are the major causes of many environmental problems due to their adverse toxic effect and their contribution to the current global warming mechanism of our planet, substantial amount of research efforts are going into cleaning gaseous streams containing VOCs in various ways[1].

Low-temperature non-equilibrium (non-thermal) plasma discharges with the help of heterogeneous catalyst aided processes represent an alternative, economical, energy efficient and also more ergonomic technology for gas phase abatement of VOCs. Here most of the energy (up to 99.9%) is utilized in the production of high-energy electrons, rather than in heating the gas[2]. Radicals, ions and other active species, which oxidize, reduce or decompose the pollutant molecules, are efficiently produced mainly via electron-impact dissociation, excitation and ionization of the background gas. The advantage of plasma discharges is that they are self-sustained. Non-equilibrium discharges have been tested for the removal of a number of different toxic or environmentally hazardous compounds, such as SO_x, H₂S, VOCs, PAHs (Polycyclic Aromatic Hydrocarbons), heavy metals, and others, like chemical warfare gases such as nerve gas.

After carefully examining all the relevant aspects of VOC removal and design considerations regarding our plasma-catalysis system we have come up with our problem statement which we will be trying to address, find supporting and reasonable explanations for our selections and find a solution for a cost effective & efficient VOC removal system:

1.2 Problem Statement

- By using non-thermal plasma in conjunction with catalytic heterogeneous chemistry and optimization of energy coupling into the plasma, economic analyses are expected to show that a more energy efficient (and hence cost effective) method based upon plasma-remediation can be used for VOC cleanup.
- Economic and technical comparison of traditional incineration based VOC removal system and our proposed device based on a case study approach.
- **Goal: To design a plasma-based system for volatile organic destruction.**

Chapter 2

Background and Literature Review

2.1 Volatile Organic Compounds (VOCs) – A critical issue

To begin with, Volatile organic compounds (VOCs) are emitted primarily as carbonaceous gases from certain solids or liquids during a unit processes in every typical industries. VOCs include a variety of chemicals, some of which may have short- and long-term untoward health and environmental effects. The most important aspect of VOCs is the fact that they are released by a wide array of process industries numbering in the thousands. Typical examples include paints and lacquers, paint strippers, cleaning supplies, pesticides, building materials and furnishings, office equipment such as copiers and printers, correction fluids and carbonless copy paper, graphics and craft materials including glues and adhesives, permanent markers, and photographic solutions[2, 3].

A lot of effort has been put in the past for tackling this ever growing concern. Leading traditional techniques for VOC removal include biological filters, two stage absorbers and the most important and widely used system is regenerative thermal incineration or regenerative thermal oxidation (RTO). These methods have been used for the treatment of the dilute off-gases from factory effluents since a good amount of time. But a big problem which is associated with such industrial equipment's is that they require relatively high energy consumption and result in high treatment costs. Gas phase hazardous organic wastes can be destroyed by allowing them to oxidize themselves to non-hazardous compounds, such as carbon dioxide and water by the application of high temperatures inside the reaction chamber. So basically, complete or partial combustion is done to convert the harmful VOCs. The most effective way of oxidizing organics is to use highly reactive species, i.e. reactants with a high oxidizing potential, such as $\cdot\text{OH}$, $\cdot\text{O}$, $\cdot\text{H}$, O_3 , and H_2O_2 . The hydroxyl radical is critical because it plays an important role in the oxidative degradation of the volatile organic compounds. In a generic combustion process, efficiency of production and concentration of these free radicals and active species depend on the process temperature which is also another important factor. For attaining the required set point temperature, huge amount of energy has to be spent to make sure that the incineration process is

completed. Incineration of gas streams is undergone by adding definite quantity of fuel which would automatically enhance and promote effective combustion, because concentration of organic material is not sufficient to self-ignite itself and keep the combustion process running for effective VOC removal. Uniformity of heating the entire gas stream is also crucial which would add up to the energy consumption parameters for the entire process consideration. Figure 1 summarizes the total volatile organic compounds emissions by source sector in the state of Pennsylvania.

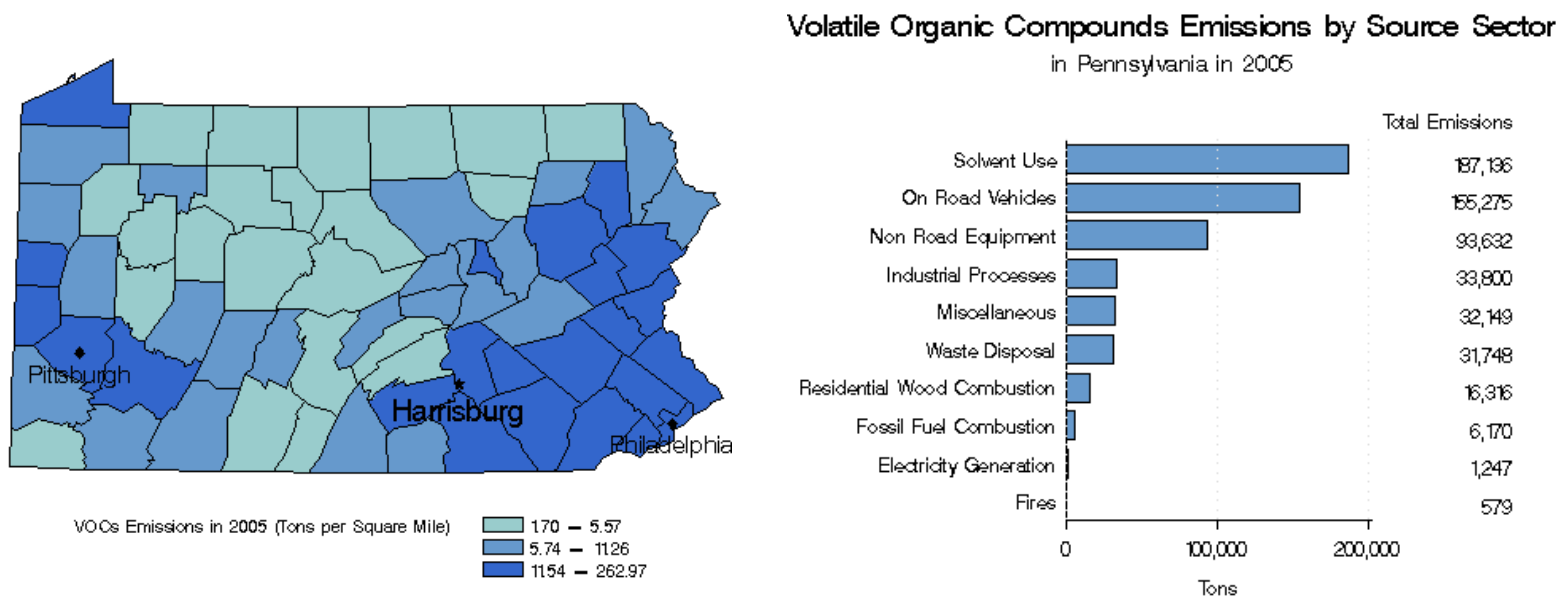

Figure 1. Pennsylvania VOC Emissions (source: epa.gov)

An organic compound is considered volatile if it vaporizes into a gas at normal room temperature and normal atmospheric pressure. Some of these vapors are dangerous to humans when inhaled in great quantities or over a long period of time. Some volatile organic compounds interrupt and destroy natural plant processes. But many of the volatile compounds have a much more complicated effect: they lead to the formation of ozone and smog which is really of great concern. Ozone is three oxygen atoms bonded together to form O₃. Ozone occurs naturally, but the introduction of large amounts of VOCs into our lower atmosphere which is basically the lowest strata of our atmosphere has caused an unhealthy amount of ozone to be created. VOCs in combination with oxygen and sunlight, leads to complex chemical photochemical reactions which eventually results in the formation of ozone. In the earth's upper atmosphere, ozone is an

important layer that protects the earth from the sun's ultraviolet rays. But closer to the earth and in layers of air which is closer to us, ozone is a dangerous compound. It mixes with other compounds in the air and becomes the main component of smog. For this reason, the EPA has determined that controlling VOCs is an effective method for minimizing ozone levels by reducing the photochemical reaction which takes place during ozone formation.

2.2 Plasma-Background Concept

Plasmas are often termed the “fourth state of matter;” the other three being solid, liquid, and gas. Simply stated, plasma is an ionized gas which conducts electricity. Figure 3 shows the comparison between three states of matter and plasma. Plasma is formed (typically electrically) by the addition of energy to a gas, which separates electrons from neutral gas molecules and atoms. Plasmas consist of charged particles including free electrons, as well as negative and positive ions, which respond to applied electric and magnetic fields. Laboratory plasmas are generated by electrical discharges.

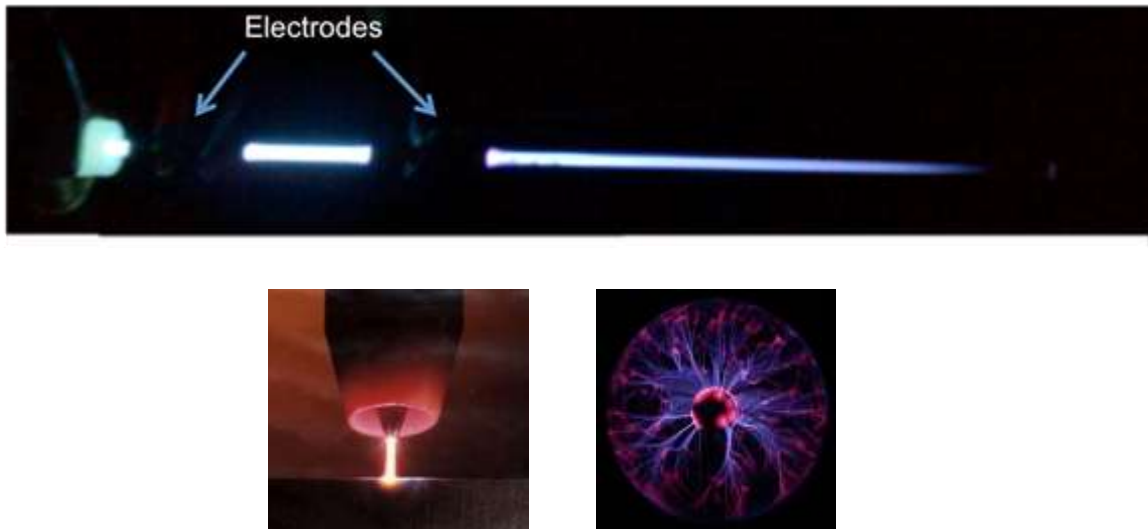

Figure 2. Different forms of non-thermal plasma (source: personal research [RVW Group])

Plasma discharges come in two main varieties, thermal and non-thermal [4,5]. Thermal kinds are typically equilibrium systems with temperatures in excess of 10,000K. Non-thermal types, in contrast, are in a thermodynamic and chemical non-equilibrium with the temperature of the electrons ($>10,000\text{K}$) greatly in excess of the gas temperature ($\sim 300\text{K}$).

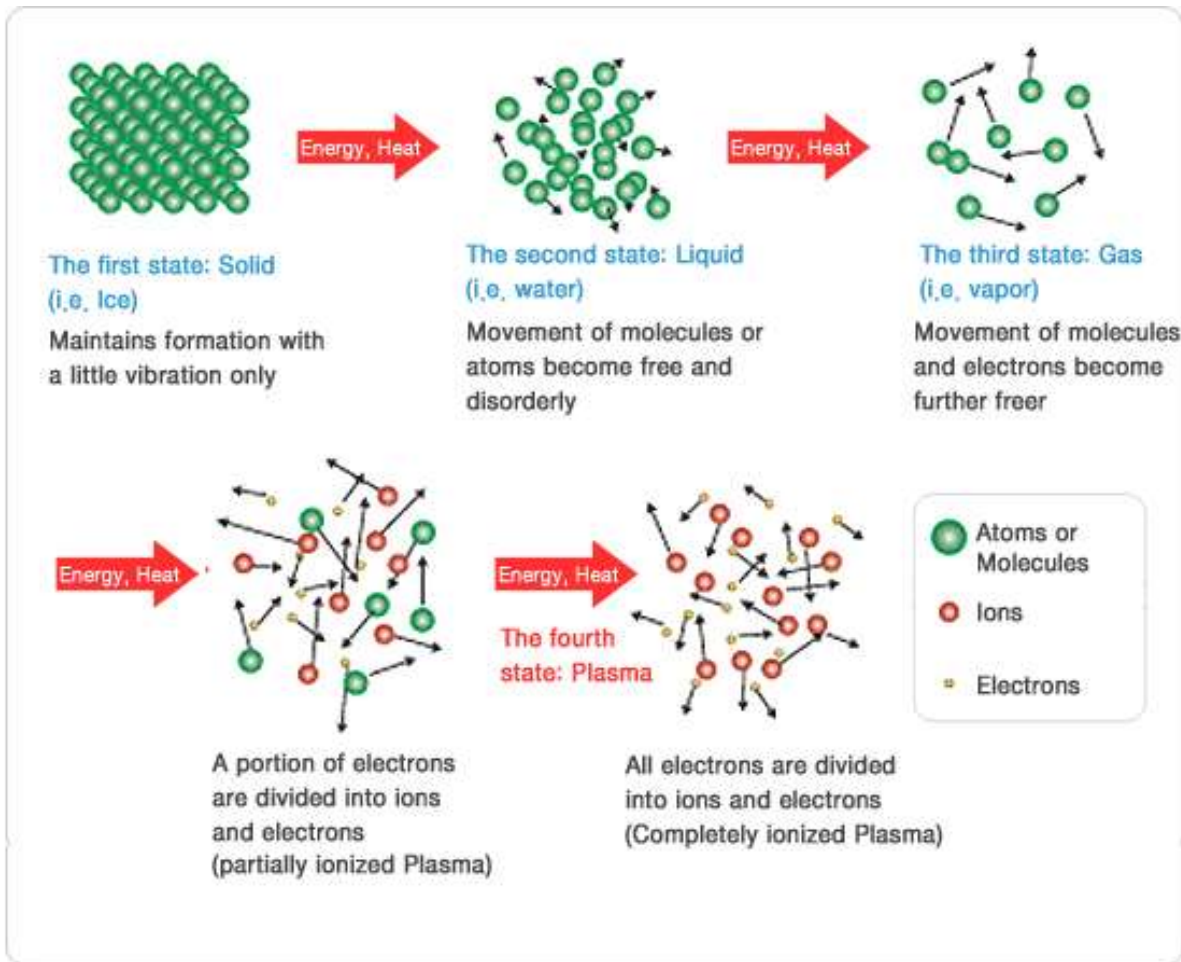

Figure 3. Comparison of four states of matter [10]

Non-thermal atmospheric pressure plasmas are the focus of this literature review and the basis of this integrative design. Their non-equilibrium nature allows for the creation of active species without generating excessive heat, which may damage surfaces or cause excessive dissociation. Also, the chemical processes which occur in the non-equilibrium plasma are beyond those which are accessible by the addition of only thermal energy. Non-thermal plasmas thus find many diverse applications in the controlled treatment of materials. Operation at atmospheric pressure allows for ease of use and lower costs, among other advantages. However, there are also important challenges to using non-thermal, atmospheric pressure plasmas.

2.3 The Process

What Is Non-Thermal Plasma?

Everyone is familiar with static electricity that occurs when reaching for a metal door handle after walking across a carpet. In technical terms, static electricity is the discharge of electricity that occurs when the potential (that is, voltage) exceeds the insulating effect of the air gap between your finger and the door handle. Non-thermal plasma uses a reactor that utilizes a similar effect [5, 6]. The reactor consists of two electrodes (one electrode is in the form of a metal pipe, and the other electrode is a metal wire that runs down the middle of the pipe) separated by a void space that is lined with a dielectric material and is filled with glass beads. This type of reactor is called Dielectric-Barrier Discharge (DBD). See Figure 4.

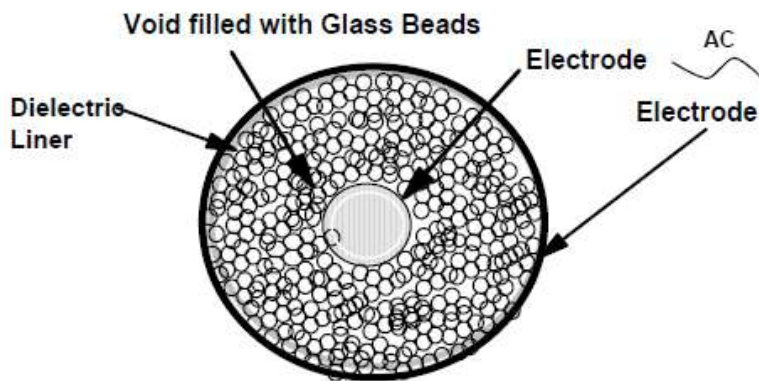

Figure 4. Dielectric barrier discharge (DBD) [11]

Emissions flow inside of the pipe. A phenomenon occurs when the voltage through the beads exceeds the insulating effect of the beads and millions of micro-discharges occur. The duration of these discharges is measured in nano-seconds. The individual discharges cannot be seen with the human eye, but the overall effect produces a silent glow. This effect will only occur when the power source is alternating current (AC) [7]. DBD cannot be induced with direct current (DC) power because the capacitive coupling of the dielectric necessitates an AC field.

In this environment, in addition to electrons flying about, atoms are being separated from their molecules to become free radicals. Since free radicals are highly reactive, they quickly recombine with other atoms and/or molecules to form new compounds. Using oxygen as an

example, the normal state of oxygen is a molecule containing two oxygen atoms. Thus, it is written as O₂. In a DBD field, the oxygen molecules splits into two atoms of oxygen, O⁺ and O⁺. The elemental oxygen radical, being very reactive, will form ozone, O₃, when the radical oxygen atom reacts with a normal molecule of oxygen (O₂).

The oxygen radicals also react with other compounds. For example, oxygen radicals react with carbon monoxide (CO) to form carbon dioxide (CO₂), sulfur dioxide (SO₂) to form sulfur trioxide (SO₃), and nitrogen oxide (NO_x) to form nitric acid (HNO₃) in the presence of moisture. Ozone will also react with small (2.5 micron) carbon particles (soot) to form carbon dioxide, and reacts with elemental mercury (Hg) to form mercury oxide (HgO). Oxidizing elemental mercury changes it from a vapor to a solid phase. Sulfur trioxide hydrolyzes into sulfuric acid, when exposed to moisture. Depending on the concentrations of nitrogen and sulfur compounds, this process is capable of producing significant amounts of mineral acids.

2.4 Pollution Control- Conventional Method

The heart of most pollution control technologies is a basic concept we all are quite aware of. That concept is oxidation; it causes compounds (in this case, contaminated air pollutants) to be broken up and reformed into new (in this case, safe) compounds. Upon adding the appropriate and definite amount of heat and oxygen to hydrocarbons oxidation process takes place. In scientific terms, the process can be written in the form of an equation:



In the thermal oxidation process, the contaminated air is heated, breaking apart the bonds of the contaminated compounds. The molecules will reform naturally, bonding into carbon dioxide and water vapor and releasing energy, the basic premise to all forms of oxidation [8].

In general, the selection process is dependent on these three criteria [9]:

- Airflow (SCFM or Nm³/hr)
- Contaminants (VOCs) in the airflow
- Concentration of contaminants in the airflow (Also called the percent Lower Explosive Limit / %LEL)

2.4.1 Regenerative Thermal Incinerators

The Regenerative Thermal Oxidizer is a thermal oxidizer consisting two or more ceramic heat transfer beds, which act as heat exchangers and a Purification Chamber or Retention Chamber where the volatile organics are oxidized and converted to CO₂ and H₂O vapor.

a) Operational concepts

The operation of a Regenerative Thermal Oxidizer (Dual-Bed) is shown in the figure shown below it requires the initial preheating of the ceramic heat transfer beds to a temperature of 1500 °F during the start-up mode. This is accomplished by operation of fuel fired burner located in the purification chamber. To equalize the preheating of the ceramic heat transfer beds, the air is directed into and out of the ceramic heat transfer beds by operation of two (2) pneumatic diverter valves located under each ceramic heat transfer bed. During initial start-up outside air is supplied to the oxidizer through the make-up air damper tee located on the inlet side of the process air fan.

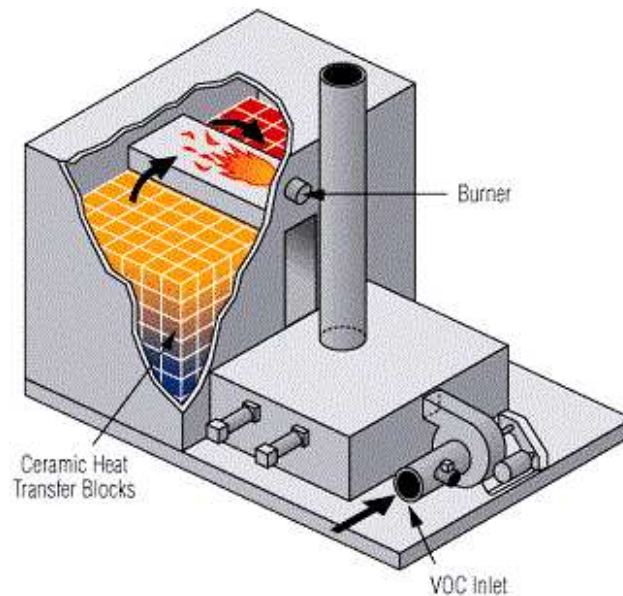

Figure 5. A typical thermal incinerator used for VOC destruction [12]

A Programmable Logic Controller (PLC) monitors and controls the direction of the air flow. After the ceramic heat transfer beds have reached an operating temperature of 1500 °F the unit is ready for the process airstream. As the process airstream enters the ceramic heat transfer beds, the heated ceramic media preheats the process airstream to its oxidation temperature. Oxidation of the airstream occurs when the auto-ignition of the hydrocarbon is reached. At this point the heat released by the oxidation of the process hydrocarbons is partially absorbed by the inlet ceramic heat transfer bed. The heated air passes through the retention chamber and the heat is absorbed by the outlet ceramic heat transfer bed. If the oxidizer is self-sustaining the net increase in temperature (inlet to outlet) is 100 °F.

During the normal Mode of Operation of the system the process air enters the RTO System Fan and passes through the Inlet Diverter Valve where the process air is forced into the bottom of the left ceramic heat transfer bed. As the process air rises through the ceramic heat transfer bed, the temperature of the process stream will rise. The top of the beds are controlled to a temperature of 1500 °F. The bottom of the beds will vary depending upon the temperature of the air that is coming in. If it is assumed that the process air is at ambient conditions or 70 °F, then as the air enters the bottom of the bed, the bottom of the bed will approach the inlet air temperature of 70 °F. The entering air is heated and the media is cooled. As the air exit the ceramic media it will approach 1500 °F. The process air then enters the second bed at 1500 °F and now the ceramic media recovers the heat from the air, and increases in temperature. At a fixed time interval of four to five minutes, or based on thermocouple control, the diverter valves switch and the process air is directed to enter the bed on the right and exits the bed on the left. Prior to valve switching the air heated the right bed and now this bed is being cooled. The cooling starts at the bottom and continues upward because the media is hot and the energy is transferred. The process air then goes through the purification chamber and exits through the second bed.

b) Cost Information

The following are approximate cost ranges (expressed in 2002 dollars) for packaged recuperative thermal incinerators of conventional design under typical operating conditions, developed using EPA cost-estimating spreadsheets and referenced to the volumetric flow rate of the effluent stream treated. The costs do not include costs for a post-oxidation acid gas treatment system.

Costs can be substantially higher than in the ranges shown when used for low to moderate VOC concentration streams (less than around 1000 to 1500 ppmv). As a rule, smaller units controlling a low concentration waste stream will be much more expensive (per unit volumetric flow rate) than a large unit cleaning a high pollutant load flow.

- **Capital Cost:** \$25,000 to \$212,000 per sm³/sec (\$12 to \$100 per scfm)
- **O & M Cost:** \$10,000 to \$53,000 per sm³/sec (\$5 to \$25 per scfm), annually
- **Annualized Cost:** \$17,000 to \$95,000 per sm³/sec (\$8 to \$45 per scfm), annually
- **Cost Effectiveness:** \$105 to \$2,000 per metric ton (\$95 to \$1,800 per short ton), annualized cost per ton per year of pollutant controlled.

2.5 Motivation for a Non-Thermal Plasma system for VOC removal

Considering the overall effectiveness and related advantages of non-thermal plasma systems over conventional thermal incinerators in terms of lower temperature operation, better destruction efficiency, more compact systems, lower energy and cost requirements it will really be worth to look at designing such a system. It obviously understandable that thermal incinerators are something which have already been tried, tested and used and the point which should be looked at is if a better and newer alternative could be found for similar purposes.

So the salient and the driving points in a Non-thermal plasma catalysis reactor system are:

- Distinctive ability of Non thermal plasma reactor systems.
- Moderate operating conditions
- Chemical reactions mainly involve free radicals
- Offers the flexibility of reactor systems
- The mechanism of catalytic reactions.
- Optimization of the hybrid system for better VOC destruction.

Chapter 3

Chemistry

The chemistry part of the Integrative design project deals with different aspects pertaining to the formation of reactive species, reaction of reactive species with neutral molecules (in our case VOC compounds) & formation of final products (destruction of VOCs).

Spectroscopic measurements can detail the operational characteristics of the plasma while providing key data on the chemical pathways of VOC destruction. Most of the models-to-date have been transferred from combustion or otherwise adapted, but there is a lack of confirmatory data on key reactions. Both model and analytical measurements are necessary to meet this goal of determining species reaction pathways [13]. Additionally, with varied spectral resolution to detect different species in energetic ions, neutrals and temperature may be remotely accessed. Such feedback is critical to assessing electrical coupling, energy distribution within the plasma and advantageous effects associated with catalysts and nano-structured electrodes and/or supplementary plasmas.

3.1 Reaction Mechanism & Performance Evaluation of Chemical Reactions in Nonthermal Plasmas

In this section we can understand the core concepts of Primary processes, investigation of reactions, reactivity vs. selectivity, efficiency.

3.1.1 Primary Processes: Formation of Reactive Species

- The chemical effects occurring in an electrical discharge are the consequence of energy injection into a gas stream by way of electron-impact processes under the influence of an electric field.
- Collisions of energetic electrons with neutral species produce ionization, fragmentation of molecules, and electronic, vibrational, and rotational excitation of the neutral gas.
- The elementary processes in non-thermal plasma can be broadly divided into a primary process and a secondary process based on the time scale of streamer propagation. The below figure summarizes the typical timescale of the elementary processes in NTP.

- The primary process (typical time-scale of about 10^{-8} s) includes ionization, excitation, dissociation, light emission, and charge transfer.
- The efficiency of the primary process is highly dependent on the energization methods and their parameters, such a pulse, DC + Pulse, AC, AC + pulse or DC, voltage rise-time, and frequency, etc.
- The secondary process is the subsequent chemical reactions involving the products of primary processes (electrons, radicals, ions and excited molecules).
- Other radical species and reactive molecules (O_3 , HO_2 , and H_2O_2) are also formed by radical-neutral recombination in the secondary processes.

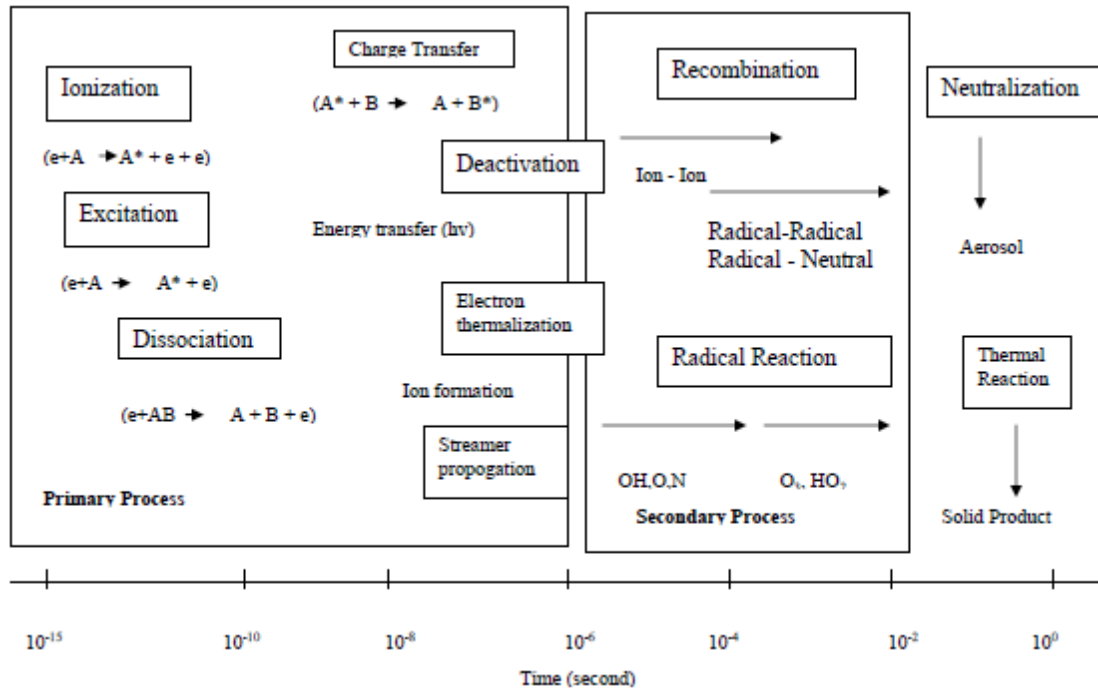

Figure 6. Timescale events of elementary processes in a non-thermal process [13]

- The typical timescale of the secondary processes is very fast (around 10^{-3} s), gas residence time in NTP reactor usually has little or no influence on the overall performance.
- The total efficiency, η_T , of the NTP process will be the product of the efficiencies of the primary process and of chemical reactions in the secondary process.

$$\eta_T = \eta_{\text{Primary}} * \eta_{\text{Secondary}}$$

- Since the reactive species responsible for the decomposition of air pollutants are highly dependent on the nature of the pollutants, studies on the formation of chemically reactive species and their reaction pathways are essential for optimizing the NTP processing for real applications.
- Chlorinated hydrocarbons are very resistant to OH-radical attack but easily decompose by dissociative electron attachment due to the high electron affinity of halogen compounds.
- Olefin compounds and unsaturated hydrocarbons are highly reactive to radical species and ozone, and are easily decomposed in the NTP process.
- Formation of OH-radical in nonthermal plasma has been studied by a laser-induced fluorescence (LIF) method, optical-emission spectroscopy (OES), and a CO-oxidation monitoring method.
- Ozone formation can be measured by UV absorption at 254 nm.

Table 1. Energy cost (EC) and G-value required for the formation of reactive species [15].

Radicals	Reactor	Td	Gas	G-Value molecules/ 100 eV	EC eV/molecules
O(¹ D)	DBD	150	Humid air (H ₂ O 2.2 wt.-%)	1.4	
	DBD		6% O ₂ , 5% H ₂ O, 9% CO ₂	1.1	
O(³ P)	Pulsed	200	19% H ₂ O, 0.5% O ₂ , 9.5% CO ₂ ,	3.3	
	Streamer	800	71% N ₂ 5% O ₂ , 16% H ₂ O, 8% CO ₂	0.25	
O(³ P)+O(¹ D)	DBD		Air	3.4–3.8	
	DBD		6% O ₂ , 5% H ₂ O, 9% CO ₂	1.0	
OH	DC	150	5% O ₂ , 6% H ₂ O, 15% CO ₂	0.2	238
	(impulse)		Humid air (H ₂ O 2.2 wt.-%)	1.4	
	DBD		6% O ₂ , 5% H ₂ O, 9% CO ₂	0.6	
	DBD		NO–N ₂	0.21	
N	Streamer	800	5% O ₂ , 16% H ₂ O, 8% CO ₂	0.37	70
	Pulsed		NO–N ₂		

	Pulsed Pulsed	205	345 Torr Dry air (assuming electron mean energy of 4 eV)		80-180 1440
electron	Streamer	800	5% O ₂ , 16% H ₂ O, 8% CO ₂	0.7	

- Most of the simulation studies only consider the collision of electrons with gas molecules in the ground state. However, the chemical effects resulting from the electron-molecule collision are highly dependent both on the electron energy and also the energy state of the molecules.
- A streamer is subdivided into primary and secondary parts depending on their appearance time. The electrons mean energy in the primary streamer is around 9 eV, while it is only about 2 eV for the secondary streamer.
- For example considering the bond energy of oxygen is 5.2 eV; it is difficult to explain the observed results. Although the details behind this finding are still unknown, the roles of electronically, vibrationally, and rotationally excited O₂ molecules are expected to be an important factor.

3.1.2 Investigation of the Mechanism of Chemical Reactions in NTPs

- Historically the scientific community did not focus much on the physical aspects and parameters of electrical discharges [14].
- Physical characteristics of plasma based discharges include ionization processes, the mobility of ions and also dependencies of temperature and pressure on process conditions. But unfortunately, the chemical aspects of such systems were not given that much attention.
- In the germinating stage scientists from radiation chemistry tried to delve deep into the reaction mechanisms associated with the so called 4th state of matter.
- The study of subsequent chemical reactions is also very important in the sense that it gives a very clear picture of the ions and radicals formed inside the plasma reaction process.

- According to the cluster theory instituted in 1928, the chemical changes occurring inside a complex plasma is attributed to the reactions of ions with molecules through clusters as intermediates.
- To understand more about radicals as intermediates, the radical theory was propounded which used the tool of mass spectroscopy to analyze and monitor early stages of typical plasma enhanced chemical reactions. Some typical reactions happening in such conditions are :

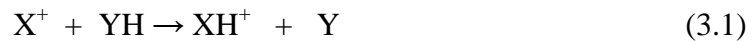

- It was inferred that both ionic and radical reactions are constituted in chemical reactions in radiation chemistry. Basically the entire process is divided into two separate processes.
- The primary process is crucial in terms of ionic reactions which result in radical formation subsequently used in secondary processes as intermediates.
- In non-thermal plasma processes radical reactions are given top priority while studying reaction mechanisms due to their corresponding slow reaction rates. Ionic reactions take place at a faster pace and are hence not considered rate determining reactions.

3.1.3 Reactivity versus selectivity in Radical Reactions

- Chemical Reactions involving radicals usually proceed very fast due to their high reactivity. On the other hand selectivity is required to achieve reasonable performance in terms of energy efficiency and byproducts [15].
- The below figure shows the schematic pathways of some radical reactions.
- The most desirable pathway is the channel-1 (CH-1) of radical-pollutant reactions. Unfortunately high reactivity usually means a poor selectivity.
- Competing reactions (CH-2) also occur at the same time. These competing reactions may lead to a poor selectivity of the radical, especially when degrading dilute pollutants.

- To estimate the contribution of radicals in the decomposition of pollutants, we introduced the reaction efficiency of radical (η_{radical}), which is described as the fraction of radicals that participate in the reaction with pollutants, as follows.

$$\eta_{OH} = \frac{k[OH][Pollutant]}{\sum \text{reaction rates involving OH radicals}}$$

- The use of OH radicals to decompose dilute pollutants seems to be energy consuming; therefore the potential uses of OH will depend strongly on the application.
- For example, η_{OH} in the decomposition of 5 ppm diphenyl ether was estimated to be 4.9%. On the other hand, ozone usually has low reactivity, with high selectivity in some cases. For example, in an NO/SO₂/humid air mixture, ozone is a selective oxidant for NO.
- Reactions with O₃, HO₂, and self-recombination of OH-OH have been considered as the loss channel of OH; hydrogen peroxide (H₂O₂) was identified from the product analysis.

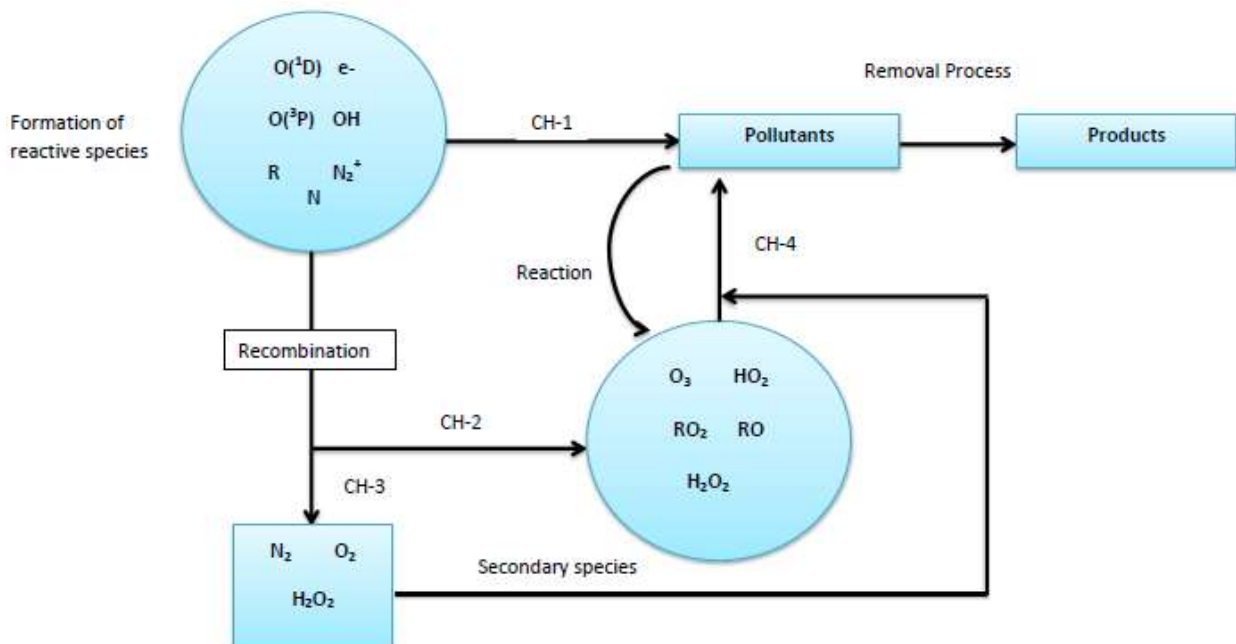

Figure 7. Reaction pathways of radicals [15]

3.2 Plasma Chemistry and Destruction Mechanism

Several theoretical concepts are being developed and evaluated to accurately determine the mechanism of destruction pathways in the plasma reactor for each compound and also for families of hydrocarbons. The most likely and commonly accepted pathway for VOC destruction is the collision pathway. The electric field in the reactor generates free electrons that undergo both elastic and inelastic collisions as they move through the field. When the electrons have an elastic collision with molecules, they retain most of their kinetic energy.

When electrons are accelerated in very strong electric fields, they eventually possess enough energy to have an inelastic collision with molecules. In these collisions the electrons transfer, all or a significant part, of their kinetic energy to the molecules. The following events might occur as the result of such collisions [16]:

- Electrons are attached to electronegative species to form anions.
- Molecular species are dissociated to smaller species resulting in formation of ions or free radicals.
- Molecular and elemental species go into excited states.
- Species are ionized to form positive ions and further free electrons are generated.
- Molecules break down into their elemental components.

The above events depend on the electron energy in the reactor and the type of molecular species present in the reactor. Usually the energy requirement is 5 to 25 electron volts (eV) for the formation of positive ions by electron removal and less than 5 eV for electron attachment and formation of anions. Similar to the above discussed effects, another phenomenon possible in the reactor is photoelectric effect [17]. In photoelectric effects, photon emissions activate the collisions that result in ionization, radical formation, and excitation that lead to chemical reactions. The electron and proton collisions proceed in similar pathways.

The actual development of destruction mechanism requires a lot of information of spatial and time-resolved electron energy distribution function and byproduct formation. There are numerous intermediates that are possible during the destruction of any given VOC in a plasma reactor depending on the nature of the molecular and reactor conditions.

Yan et al. [18] proposed a simplified global mechanism for the destruction of air pollutants in pulsed corona reactors which involves a free radical mechanism. The mechanism is described in the following steps:

1. The first step is Radical Production, which is the initiation step in the pathway:



2. The following step is the Pollutant Removal, which is the propagation mechanism:



3. Finally, termination of the reaction takes place in the following possible reactions:

- a) Radical Linear Termination



- b) Radical Nonlinear Termination



Where R, X, A, B, C and M are radical, pollutant, byproducts and bulk gas compounds respectively. According to them, VOCs follow Radical Linear Termination. Using simplifying assumption, they derived the expression for conversion of the pollutant as:

$$\frac{[x]}{[x]_0} = \exp\left(\frac{-E}{\beta}\right) \quad (3.4)$$

Where [x] and [x]₀ are the initial and final concentration of the pollutants, and β is given as:

$$\beta = \frac{k3.M}{k2.k1} \quad (3.5)$$

A possible destruction mechanism for toluene that can be resolved in terms of the above mechanism is given by Nunez et al. [19]. The initial step is the reaction of one of the resonance structures of toluene with excited oxygen species produced in the reactor:

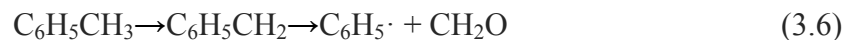

The benzyl radical in turn reacts with another excited oxygen species to form decomposition products in the propagation reaction:

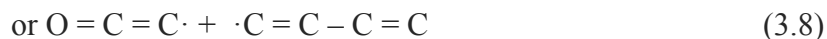
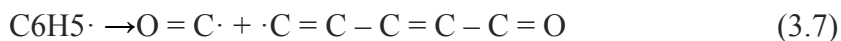

The termination step is the reaction of the $O=C\cdot$ or the $O=C=C\cdot$ radical with another excited oxygen to form CO_2 or CO .

3.3 Electron Impact Processes

Plasma Chemistry is very unpredictable and complex. Some of the most common electron impact processes are discussed below.

Electron-impact dissociation of molecular oxygen produces the ground state atomic oxygen $O(^3P)$ and excited atomic $O(^1D)$:

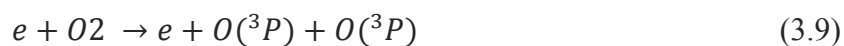

In humid air mixtures, OH radicals can be produced in a variety of ways. In discharge reactors for which the electron mean energy is low, the OH radicals are produced via three types of reaction:

Electron Attachment



Direct dissociation by electron impact



Dissociation by $O(^1D)$



In electron beam reactors, the OH radicals originate mainly from the positive ions reacting with H_2O . The sequence of fast steps is as follows:

Electron impact ionization



and similar ionization processes to produce molecular ions N_2^+ , H_2O^+ , CO_2^+ ;

Electron-impact dissociative ionization



and similar ionization processes to produce N^+ , H^+ ; *charge transfer reactions to form additional O_2^+ ions*, such as



formation of water cluster ions



dissociative reactions of water cluster ions to form OH

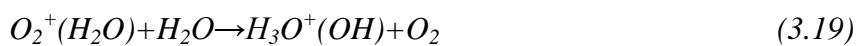

followed by



3.4 Case Study

The Oklahoma Air Logistics Center at Tinker Air Force Base in Midwest City, Oklahoma requires a control technology to reduce the emission of Volatile Organic Compounds (VOCs) from its paint booths, to obtain compliance with Title III of the US Clean Air Act 1990 and MACT (Maximum Achievable Control Technology). Currently, paint with low pigment content is being used to paint aircraft as it has low VOC content.

The low pigment paint is not as good in quality as the high pigment paint. Hence, the aircrafts require frequent repainting. Tinker would like to switch to high pigment paint but the higher VOC emissions results in the need for a control technology. There are of 42 paint booths that operate 5 –6 hours a day. The entire painting operation is performed in 15 minute intervals.

Hence, Tinker needs a control technology that can be turned on and off when required and instantly operate to full capacity.

The general operating characteristics in paint shops have been discussed in detail in the Federal Facilities Sector Notebook. The VOC emission inventory obtained from Tinker is shown in **Table 2**. The inventory lists the major chemicals emitted from paint booth B2121 and their calculated emission rate in 2010.

Table 2

Emission Inventory of B2121 Paint Booth Showing
Calculated Values of Annual VOC Emissions

CAS NUMBER	NAME OF COMPOUND	TONNES / Yr
4035-89-6	1,6-Hexamethylene Diisocyanate	0.093
28182-81-2	Aliphatic Isocyanate	0.086
64742-95-6	Aromatic Hydrocarbon	0.071
78-92-2	Sec-Butyl Alcohol	0.057
13463-67-7	Titanium Dioxide	0.055
763-69-9	Ethyl 3-Ethoxypropionate	0.054
123-86-4	Butyl Acetate	0.049
108-10-1	Methyl Isobutyl Ketone	0.045
110-43-0	Methyl N-Amyl Ketone	0.041
108-941	Cyclohexanone	0.025
78-93-3	Methyl Ethyl Ketone	0.015
108-88-3	Toluene	0.012

Here in this section we will discuss particularly on destruction of Toluene which is one of the major VOC.

3.4.1 Alternative Methods of Toluene Destruction

- Toluene can be removed by adsorption using activated carbon, thermal oxidation and incineration, bio-filtration and plasma destruction.
- Carbon adsorption is cheap and effective (90%) compared with other methods but the presence of high concentrations of ketones and alcohols can cause fire in a carbon bed.

- Finally, the destruction VOCs using an alternate current plasma reactor is effective (>95% *Destruction Efficiency*) and potentially less expensive than other competing technologies.

3.4.2 Toluene Destruction using a non-thermal plasma reactor

- Numerous reactions may take place in a DBD plasma reactor that can lead to the formation of active species capable of reacting with pollutant molecules.
- These species react with pollutant molecules, which can result in near complete oxidation of hydrocarbons into CO, CO₂, H₂O and conversion of species such as Cl, S and NO into HCl, Cl₂, SO₂, H₂SO₄, HNO₃.
- If the concentration of the active species is high enough to initiate the destruction reaction, the pollutant concentration decreases.
- The complete reaction **chemistry** is extremely complicated. The reactant molecules are known to undergo a series of *intricate intermediate reactions* before breaking down completely destroying into combustion products.
- Due to the complexities of these mechanisms for pollutant destruction in DBD plasma reactors, additional research needs to be done in the mechanism of the reaction.
- The destruction of toluene in a plasma reactor occurs through **oxidation**. A possible free radical mechanism for the oxidation of toluene in the reactor is discussed below.
- Toluene can either react with the *atmospheric oxygen* or the *hydroxyl radical* once a mixture of radicals is formed in the reactor. The following reactions show one possible mechanism of toluene destruction in the DBD plasma reactor.

The most common reactions are shown below

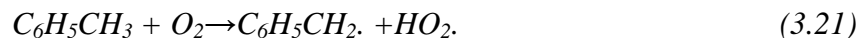

or

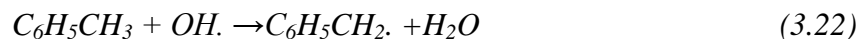

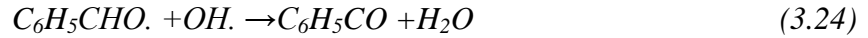

The decomposition of toluene mainly involves the following reactions: Energetic electron induced decomposition reactions:

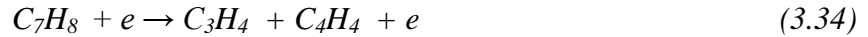
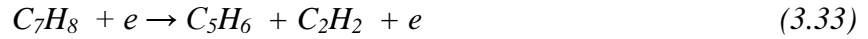

Dissociation rate coefficients can be obtained from the solution of Boltzmann equation for the electron energy distribution.

Reactions between toluene and radicals:



$$K_{400} = 3.67 \cdot 10^{-13} \text{ cm}^3 \text{ mol}^{-1} \text{ s}^{-1}$$



$$K_{400} = 1.14 \cdot 10^{-12} \text{ cm}^3 \text{ mol}^{-1} \text{ s}^{-1}$$

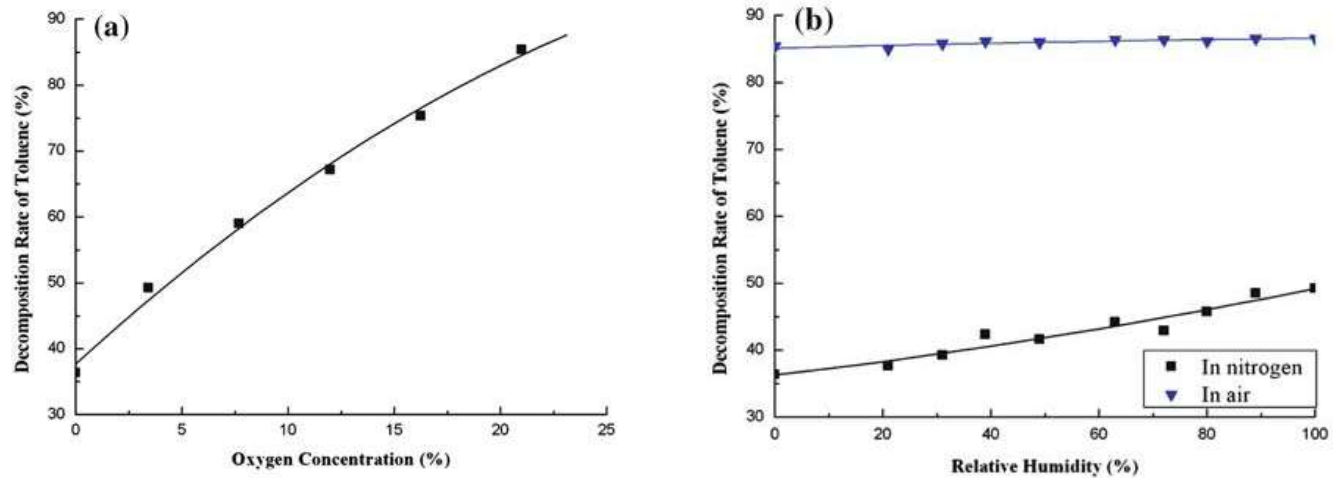

Figure 8. Decomposition rate of toluene [19]

The observations from the above two graphs can be summarized below:

- The above figures show the variations of the toluene decomposition rate as a function of the oxygen volumetric fraction and RH: this reaction rate is markedly increasing from 36 to 85% when the oxygen density is increased in the treated gas.
- It is also increasing by adding water vapor when the GA is working in dry nitrogen atmosphere.
- By contrast, the toluene decomposition rate (*85%) is not obviously affected by the presence of water vapor in air atmosphere.

3.4.3 Optical Emission Spectrum of Toluene

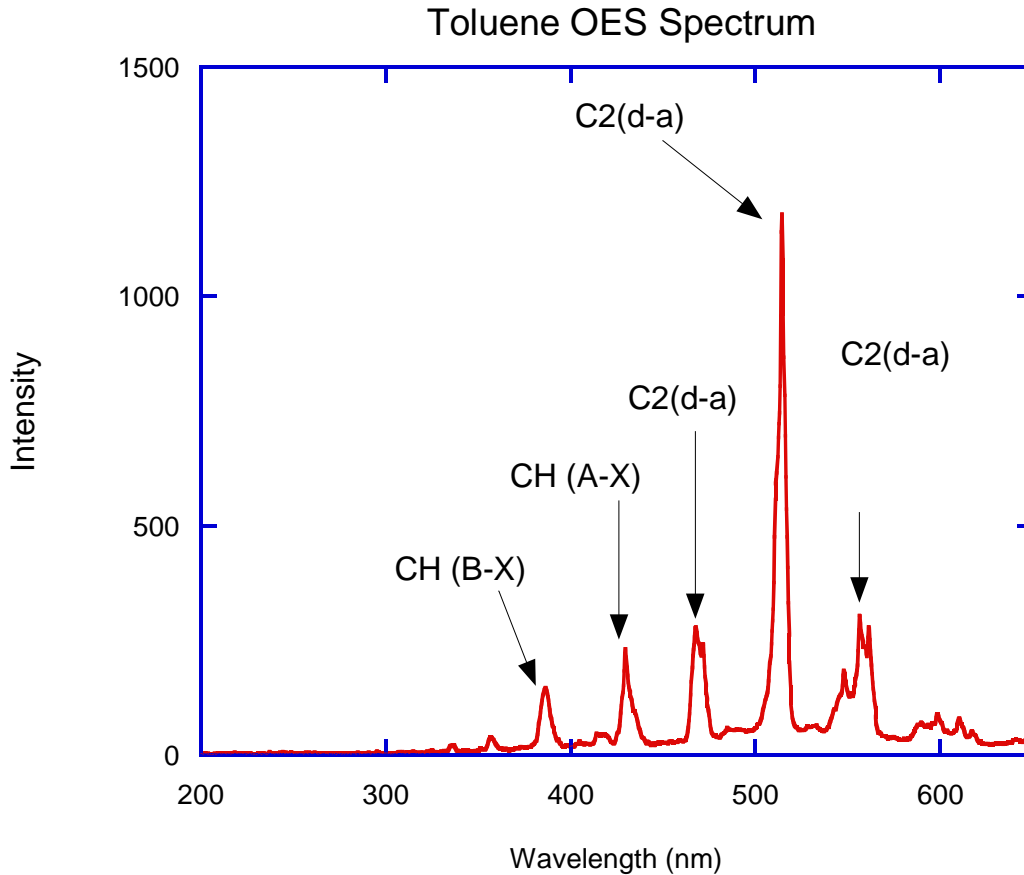

Figure 9. Optical emission spectrum of Toluene [Source: personal research]

- The toluene decomposition efficiency is strongly influenced by the presence of the O and OH radicals in the plasma region, the addition of oxygen and water vapor in the treated gas enhances the decomposition of this volatile organic compound.
- The above figure 3 is a OES (Optical Emission Spectroscopy) spectrum. We can see that the peaks are pertaining to toluene species.
- We have analyzed this in our lab, we passed 2000 ppm (which is the most common concentration in most of the VOC industries) of toluene using a bubbler through a dielectric barrier discharge type of plasma system.

- The Plasma system looks like the one that is showed initially under the plasma section (2.2).
- The plasma unit destructs the toluene molecules, breaking them down to C₂, CH(A-X), CH(B-X) species.
- In the future we are planning to pass a mixture of oxygen and also try doing with water and check how the decomposition changes.
- The addition of reactive species to the plasma system will totally change the reaction mechanism leading to different products.

Chapter 4

Literature Review for Reactor Design & Catalyst

4.1 Reactor Design

The versatility of non-thermal plasma reactors could be properly understood simply by the fact that there are at least 7-8 different configurations. The main advantage which is imparted by different configurations is the flexibility of operation and exclusiveness of application. That means that we can tailor our plasma configuration according to our operational needs and thus come up with the best and most suitable device for VOC destruction [20]. Simplicity of the device in terms of on-off operation is also another major factor which makes non-thermal plasma reactors more attractive.

Non-thermal plasma reactors can be broadly classified as follows:

- a) Pulsed corona discharge reactor
- b) Dielectric Barrier Discharge reactor
- c) Annular plasma reactors with cylindrical electrodes
- d) Rectangular plasma reactor with solid pin electrodes
- e) Gliding arc discharge reactor
- f) Packed-bed reactors

4.1.1 Pulsed Corona discharge:

The figure 10 shown is a typical pulsed corona discharge. It is created by applying a series of fast-rising, high-voltage pulses to a field-enhanced geometry such as the coaxial wire-cylinder configuration shown here. The pulses are formed by charging an energy storage capacitor (milliseconds) and then quickly releasing this energy to the reactor

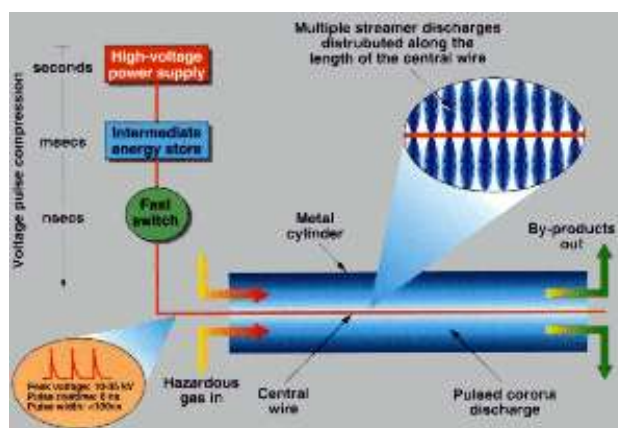

Figure 10. Pulsed corona discharge [20]

through a fast switch (nanoseconds) such as a high-pressure hydrogen spark gap. Applying these pulses generates filamentary corona discharges that are distributed down the length of the central wire. Chemically active species, or radicals, formed by the high-energy electrons contained within the discharge can then preferentially react with the pollutant molecules, converting them to less-hazardous or more easily handled compounds [21].

Since the pulsed corona discharge reactor is energized using a pulsed power supply, the energy dissipation by ions can be minimized and thus the energy consumption is reduced by a factor of five compared to that of a corona discharge using DC power.

In this case the discharge mode is streamers mode and the ionization zone is generally spread over the entire gap. Thus the electrodes gaps can be set around 10 cm which helps in the treatment of a large volume of pollutant.

4.1.2 Dielectric Barrier Discharge (DBD)

Dielectric-barrier discharges (DBD's) comprise a specific class of high-voltage, AC, gaseous discharges that typically operate in the near-atmospheric pressure range as shown in the figure 11. Their defining feature is the presence of dielectric layers that make it impossible for charges generated in the gas to reach the conducting electrode surfaces. With each half-cycle of the driving oscillation, the voltage applied across the gas exceeds that required for breakdown, and the formation of narrow discharge filaments initiates the conduction of electrons toward the more positive electrode. As charge accumulates on the dielectric layer(s) at the end(s) of each filament, the voltage drop across the filament is reduced until it falls below the discharge-sustaining level, whereupon the discharge is extinguished.

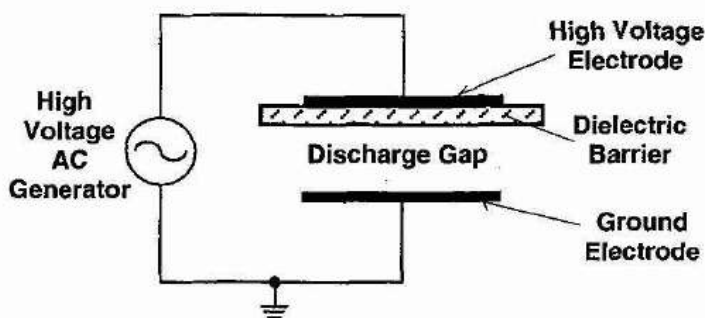

Figure 11. . Dielectric Barrier Discharge schematic diagram, DBD generating plasma [20, 21]

The discharge characteristics in DBD are dependent on:

- a) gas composition,
- b) types of dielectric materials,
- c) Operating conditions of voltage and frequency.

The advantage of DBD mode over corona discharge lies in the fact that unlike corona discharge it uses a very reliable, efficient, simple and cheap power supply whereas corona discharge requires sophisticated pulsing circuits. Moreover the dynamics of DBD is simpler, and that is why it is easier to scale it up without difficulty.

4.1.3 Capillary Plasma Reactor

This design uses dielectric capillaries that cover one or both electrodes of a discharge device, which has many similarities with a conventional DBD. But unlike DBD, CPE exhibits a mode of operation called “capillary jet mode”; In this case, the capillaries have diameters in the range from 0.01 to 1mm and length-to-diameter ratios of the order of 10:1. These capillaries serve as plasma sources, which produce jets of high-intensity plasma at atmospheric pressure under the right operating conditions [22].

A stable uniform discharge depends on using a proper capillary geometry, dielectric material and an appropriate electric field. The distinguishing feature for this configuration is the use of capillary tube, which is responsible for capillary jet plasma. At a particular voltage plasma jets are generated and thus many of such capillary tubes placed side by side gives rise to a uniform glow. The electron energy being 5-6 eV is also relatively higher than for many other plasma systems.

CPE can be broadly classified as:

i) Annular plasma reactor: This configuration tries to ensure maximum exposure of the effluent stream to the plasma generated. A schematic is shown in the figure 12.

The system consists of a pyrex glass jacketed with an Aluminum electrode and with another Aluminum electrode placed concentrically inside, surrounded by a perforated alumina silicate (dielectric).

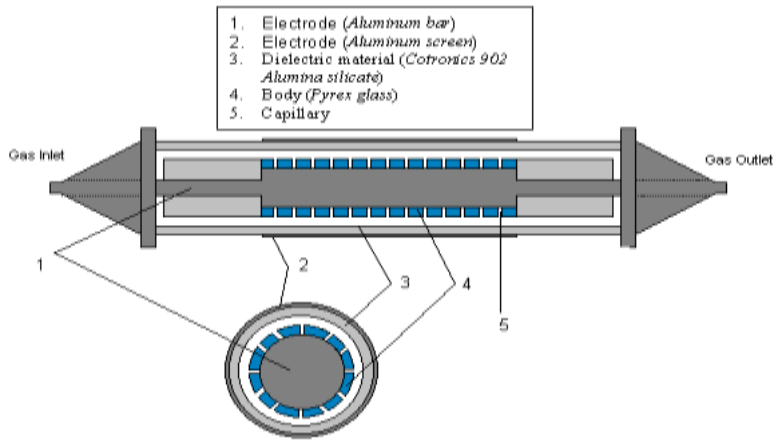

Figure 12. Annular Plasma reactor [22]

Thus the effluent gas stream while passing through the tubular reactor experiences maximum exposure to the plasma generated within the tube.

ii) Rectangular plasma reactor with pin electrode geometry:

This configuration consists of multiple rectangular pins and plate arrangement. This helps in maximizing the exposure of the contaminants to the plasma generated.

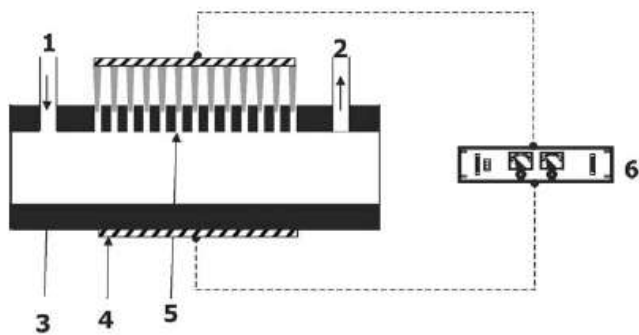

Figure 13. Rectangular plasma reactor [23]

1: gas inlet; 2: gas outlet; 3: spacer 4: dielectric; 5: stainless steel hollow pins; 6: copper; 7: capillary 8: power supply

b. Flow through regime

a. Cross flow regime

1: gas inlet; 2: gas outlet; 3: dielectric material 4: electrodes 5: capillary 6: power supply

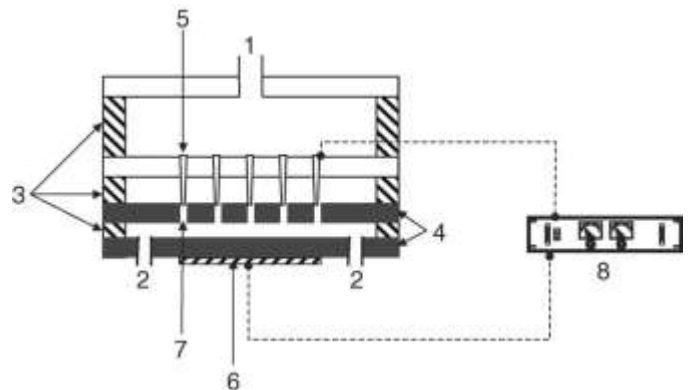

Figure 14. Modified rectangular plasma [23]

The cross-flow configuration (Figure 14) was developed first. It consisted of two parallel dielectric plates, one of which is perforated with .4 mm diameter capillaries. The cathode consists of metallic pins which are partially inserted into the capillary holes of the dielectric. The metallic pins having a very small diameter to length ratio enhances the electric field greatly and thus improves the generation and stability of plasma. The diameter of the capillaries in this case is 0.4mm.

This design was further modified and developed into a flow-through configuration (Figure 13). In this case the gas stream is introduced through the hollow pin electrodes and capillaries. This increases the exposure of the contaminants to the generated plasma further and thus makes the system very efficient for VOC destruction [22, 24].

The reactor in this case is designed to use pyrex glass instead of plastic which reduces the generation of undesirable residue. As a modification to the previous design the diameter of the capillaries in the flow through regime is increased to 0.79 mm to reduce pressure drop.

4.1.4 Gliding Arc Discharge

It is an “auto-oscillating” phenomenon. It generally requires a minimum of two electrodes immersed in a laminar or turbulent gas flow. The plasma generated is mostly in non-equilibrium nature [23]. This is shown in the figure 15

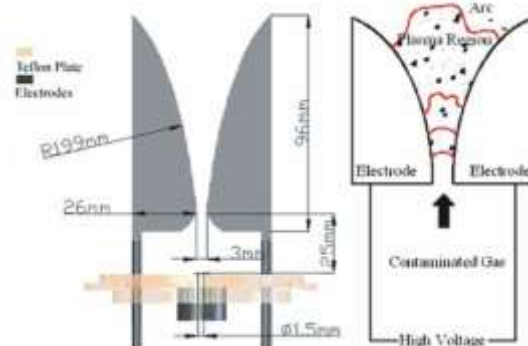

Figure 15. Gliding Arc [25, 23]

GA reactors mainly consist of thick knife-shaped electrodes fixed on a Teflon bed plate. At the shortest gap between the electrodes the gases break down forming an arc. Then the arc is pushed by the gas flow along the electrodes until the ion column ruptures. This cycle continues till the voltage is supplied. That is why this is an ‘auto-oscillating’ process. The great disadvantage of this type of reactor is that the mean electron energy is 1eV, which is very low compared to mean electron energies of DBD and PCD which is 4-5 eV and 5-10 eV respectively.

The low electron energy leads to low ion densities. But the electron density is high (about $10^{24}/\text{m}^3$ in the arc creation zone). Thus the amounts of radicals and the electrons are mainly responsible for the decomposition of VOC.

4.1.5 Packed Bed Reactors

Plasma-enhanced (Assisted) Catalysis (PEC) reactor: In case of PEC the catalyst is placed in the downstream part of the reactor [26]. This is of advantage to the system as the non-thermal plasma or NTP generally has a low temperature whereas the catalyst might require high temperature for its operation. A schematic is shown in the figure 16

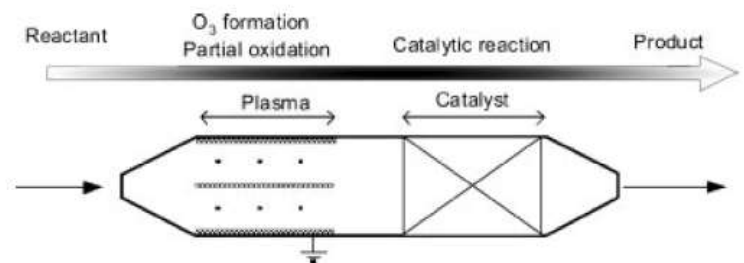

Figure 16. Packed Bed Reactor [26]

The non-thermal plasma generated has mainly two functions. It partially converts the reactant and generates ozone.

Since the catalyst has better activity for NO_2 it is more advantageous to oxidize NO to NO_2 . With this configuration this can be easily achieved as the NTP oxidizes the NO before feeding it to the catalyst.

Reducing agents such as ammonia and hydrocarbons are added at the inlet of the catalyst bed to reduce the NO_2 to N_2 . The ozone produced by the NTP enhances the VOC destruction in the catalyst bed.

4.1.6 Plasma-Driven Catalysis (PDC)

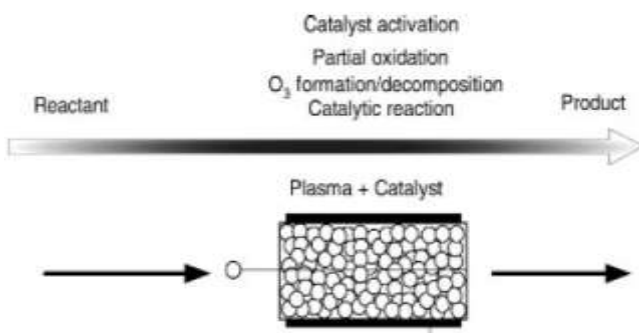

Figure 17. Plasma Driven Catalysis [1, 27]

In this type of reactor the catalyst is placed directly in the NTP reactor [1, 27]. The low temperature NTP activates these catalysts. All the gas phase reactions take place simultaneously. The catalysts used in PDC are alumina, zirconium silicate, cobalt oxide, activated carbon etc. A schematic is shown

in the figure 17, Unlike PEC more complicated mechanisms are expected in PDC system. Moreover the role of NTP in catalyst activation is not clearly understood. This leads to the difficulty in scaling up of such a reactor.

4.2 Comparison of the Reactors

Different parameters using different reactors have been studied to compare the performance in each case. The current status of VOC decomposition is reviewed with a particular case study of benzene decomposition.

4.2.1 Specific Input Energy Comparison

Figure 18 shows a comparison of benzene decomposition using five different reactors and it is evident from the graph that PDC has the best performance [3, 7, 9]. It uses the least specific energy for decomposition of a particular amount of benzene.

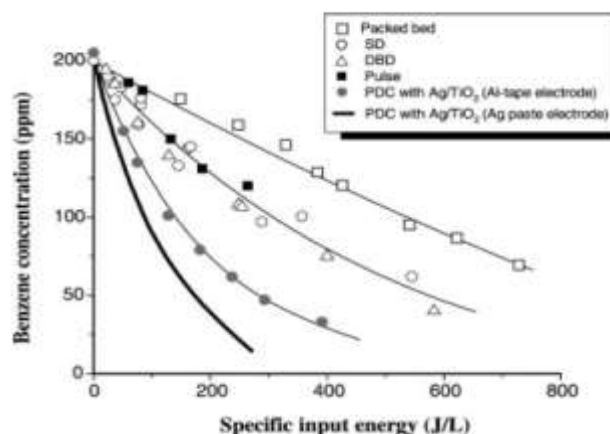

Figure 18. Specific Input Energy Comparison

Formation of aerosols has always been a problem with VOC decomposition using Non-thermal plasma. The aerosols formed are in nanometer size range and can be a cause of health hazard. In the figure 19 showing the particle size vs. the concentration in various reactors of the formation of aerosols are shown.

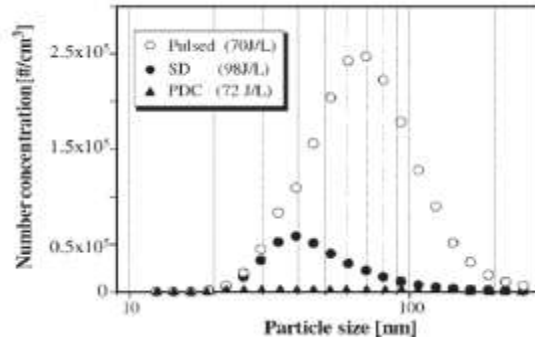

Figure 19. Comparison of aerosol formation in reactors

As it has been observed, Pulsed Corona Discharge produces the maximum amount of such nanometer sized aerosols whereas PDC reactors produce the minimum.

4.2.2 Carbon-dioxide Selectivity

The selectivity of carbon dioxide to carbon monoxide is also a crucial parameter in choosing a reactor. Carbon monoxide being a more toxic gas should be released at a minimum concentration [3, 9]. The figure shows that PDC reactors have the maximum selectivity for Carbon dioxide unlike other reactors which have more selectivity for Carbon monoxide. Thus these observations prove that PDC reactors are not only more energy efficient and economically viable but also more eco-friendly.

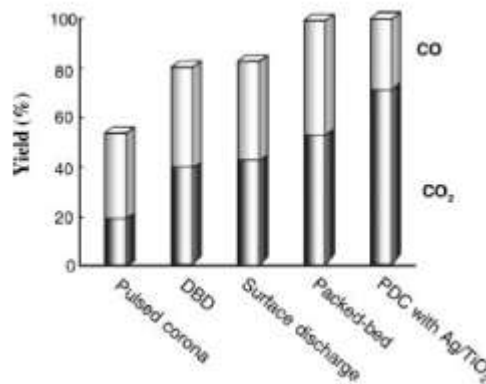

Figure 20. CO₂ selectivity

In the history of plasma processing of VOC's the two problems faced were that the system was generally less energy efficient, and produced toxic byproducts such CO, NO_x and nitric acid. The advantage of using a plasma system was that the catalyst can be combined with the system, often producing synergistic effect. Thus in using PDC systems, not only can the disadvantages be

eliminated but the system can be used with a catalyst system to enhance its potential. But since the interaction of the non-thermal plasma and the catalyst is still a topic of debate PDC systems have not generally been used for scaling-up operations.

4.2.3 Basic Design

Thus to start with, in this project, a PEC (Plasma enhanced catalysis) reactor will be considered which has the same advantages as a PDC reactor but is simpler because the fact that catalyst and the NTP part of the reactor are kept independent of each other. A schematic diagram and description of a PEC reactor has already been given [28]. The following design (Figure 21) is the basic design that is being considered for this project.

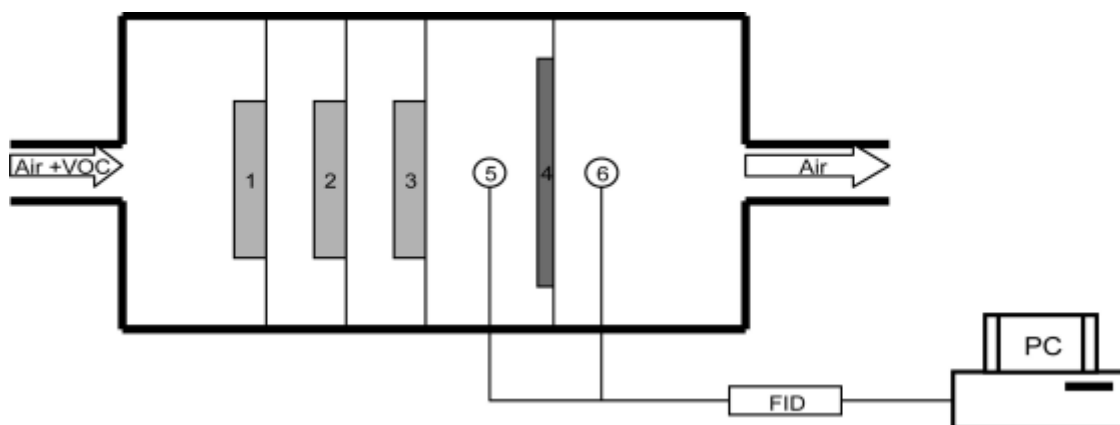

Figure 21. Basic Design of the Reactor [28]

The design considerations are as follows:

Outer Shell – Plastic device – 105X30X31cm

Plasma cell – Assembly of electrodes, glass beads

Electrodes – Stainless Steel – 12x12cm

Glass Beads – Glass – 6 ± 3 mm

Flow Rate – 300 l min^{-1}

Input Power density- $.006 \text{ kWh Nm}^{-3}$

This has been used in the industries to treat toluene. It consists of the three plasma cells (1, 2, and 3 in the diagram) which has electrodes and is packed with dielectric materials. On applying voltage plasma is generated in the cells. As air and VOC enters the cell it gets treated by the plasma generated.

The best part of the reactor lies in the fact that there is a MnO_2 catalyst in the downstream of the reactor. Reducing agents are passed through the catalyst which helps to reduce the NO_x that is coming out of the plasma cells and also reduces any ozone that has been generated. Thus the system is a self-contained system and treats all the byproducts before letting it out into the atmosphere.

Thus unlike an incinerator it creates minimal pollution. But the only disadvantage of this reactor lies in the fact that it can treat only at the rate of 300Litres/ min whereas the small scale industry targeted in the project needs a system to treat 2000 to 7000 liters / min.

4.3 Catalyst

The selection of the catalyst particles along with the ferroelectric materials plays a very important role in the formation of plasma and the treatment of the VOC's.

4.3.1 Packed Bed Reactors

Ferroelectric pellet packed-bed reactors were first developed as a type of ESP and were found to be effective not only in collecting particles (99.999% removal) but also in destroying yeast cells. Later this type of reactor was investigated for VOC decomposition, odor removal and CO_2 reduction [29]. The most widely used ferroelectric materials for packed-bed reactors are barium titanate, calcium titanate, alumina etc., out of which barium titanate is the most widely used one. It has a dielectric constant of 2000-10000. A typical packed-bed reactor is shown in figure 22 where we can see the type of packing and the typical arrangement of the electrodes in the reactor.

Working

When the ferroelectric materials are exposed to an external electric field, a spontaneous polarization occurs in the direction of the electric field, resulting in a high electric field at the contact points of the pellets. Electrical discharges, sometimes referred to as partial discharge, take place in the vicinity of the pellet's contact points.

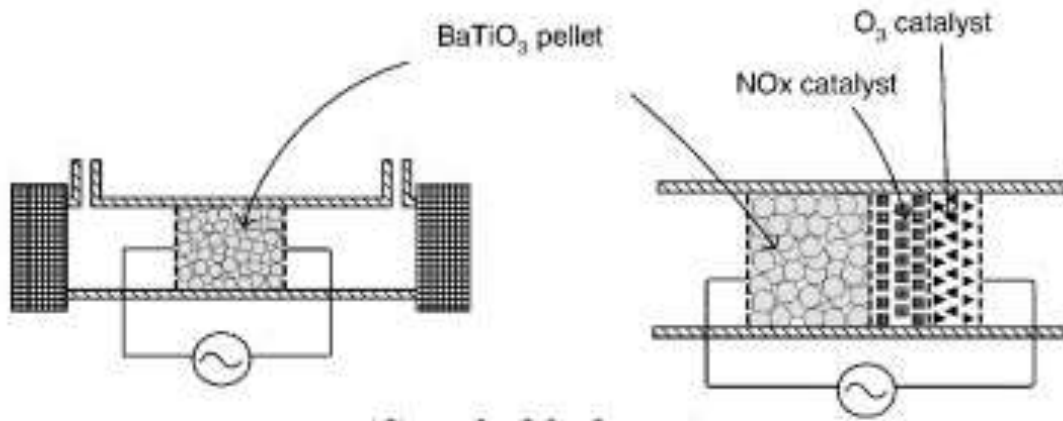

Figure 22. Packed Bed Reactor [29]

Although the use of pellets is disadvantageous in terms of pressure drop, the pellets lead to a uniform distribution of gas flow and discharge in the reactor. Ferroelectric pellet packed-bed reactors can be easily modified to accommodate a catalyst in the reactor. For practical use and the optimal design of NTP reactors, it is necessary to understand not only the physical properties but also the differences in the energy efficiency. In lab scale, the design can also affect greatly the performance of the reactor in its energy efficiency. Hence, a typical packed bed system when mixed with the catalyst particles can be divided into two categories i.e., single-stage plasma Catalytic reactor, two-Stage plasma Catalytic reactor and multistage plasma catalytic reactor depending on the location of the catalyst in the system.

4.3.2 Single Stage Plasma Catalytic Reactor (SPC)

- Alternate names: In-plasma catalysis reactor (IPCR), Plasma-driven Catalysis (PDC), Combined Plasma Catalysis (CPC).
- The SPC is constructed by integrating non-thermal plasma and catalysis in the same reactor. The catalyst can be introduced in the form of pellets, foam, honeycomb monolith or coating the electrodes.
- The catalyst region can partially or completely occupy the discharge zone. In the case of pellets, the non-thermal plasma reactor can be packed with purely catalytic pellets or a mixture of non-catalytic and catalytic ones.

- A typical single stage plasma reactor is shown in Figure [29]. In this kind of design, the catalyst is coated on the electrodes which take a role in the reduction of the VOC's for the inlet gas stream.
- Various such designs can be constructed depending on the type of catalyst that we use.

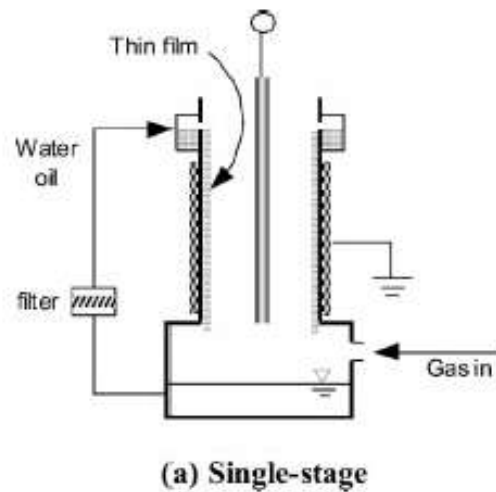

Figure 23. Single stage plasma catalytic reactor [29]

- Typically for solid catalysts, a packed-bed type of reactor is used and the packing materials are filled with the ferroelectric materials and the catalyst materials.
- The various effects of plasma on catalyst performance and vice versa is given in the figure 24 below

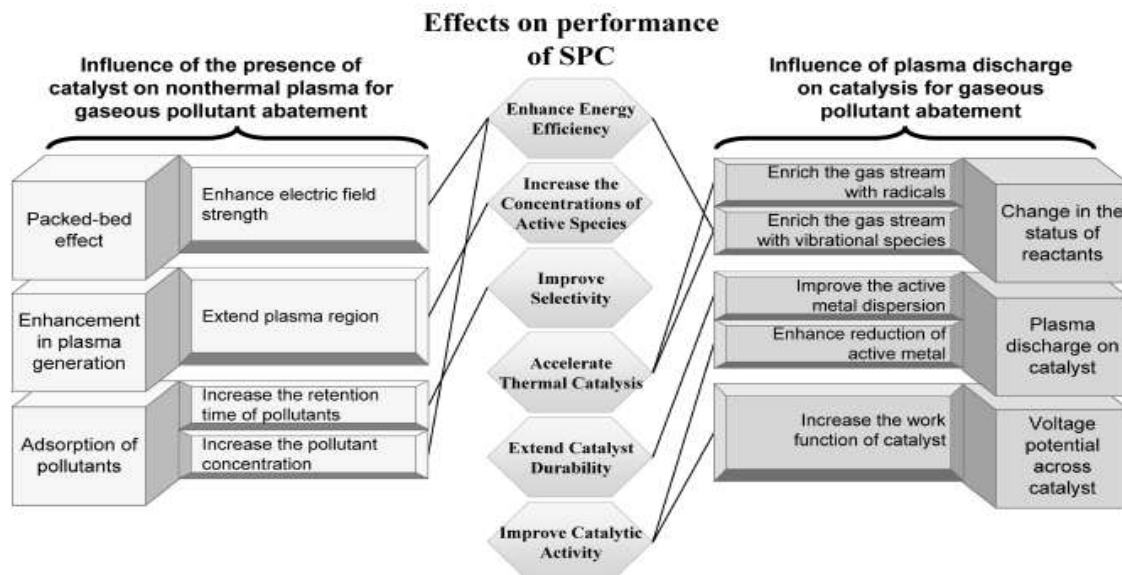

Figure 24. Illustration of performance of SPC and corresponding effects on the performance [3]

4.3.3 Two Stage Plasma Catalysis System (TPC)

This is the second type of configuration. Alternate names are Plasma Enhanced Catalysis (PEC), Post plasma catalysis (PPC) and Pre plasma catalysis (PPC) [30]. The plasma reactor could be located either upstream or downstream from the catalyst, which is termed as plasma preprocessing and plasma post processing respectively. A typical two-stage plasma catalysis is shown in figure 25.

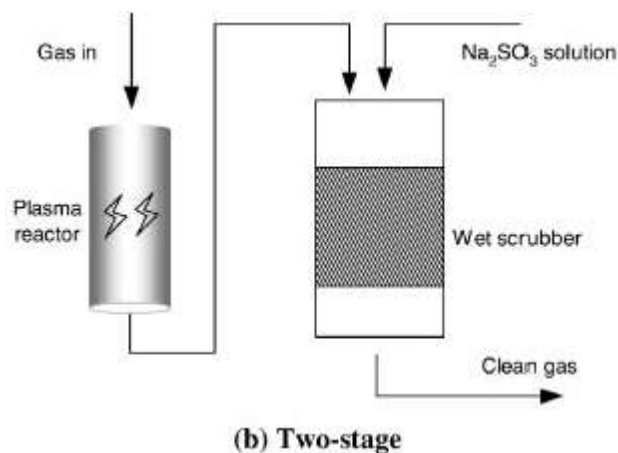

Figure 25. Two Stage Plasma System [30]

In this kind of system, we can see that the catalytic bed is located after the plasma reactor. It is an example of post plasma catalysis. The gas molecules after treatment with plasma are then passed into the catalyst bed where the plasma treated gas which forms radicals is then passed on the catalyst bed where they get adsorbed. The following problems may occur in this type of configuration

- Ions and electronically excited species would have de-excited before they reach the catalyst surface.
- The internal energy of the species in rotational state is not sufficient to induce the catalyst surface.
- Radicals generally show a much higher sticking coefficient for chemisorption, an essential step of catalytic reactions.

- Although the internal energy of vibrationally excited species is not enough to induce plasma chemistry reactions, they are the active species produced in plasma with the minimum internal energy to improve catalytic reactions.

Hence, the preprocessing configuration is used, if we use two-stage plasma catalysis. The following are some of the advantages of this kind of system:

- The products generated after the treatment by catalysis are generally more stable compared to those from plasma treatment.
- Plasma can generate a significantly beneficial effect on the following plasma treatment.
- The NO_x removal is higher in this type of configuration.

Hence based on these reasons, SPC is considered over TPC. Also, it has been experimentally demonstrated in various studies that SPC could achieve a better performance for gaseous pollutant removals, which are believed to be stemmed from the performance enhancement mechanisms. In terms of VOC abatement, the byproducts generated after plasma treatment, such as CO, NO_x and O₃ are an important issue that should be taken into account. As SPC offers a considerable efficiency in the removal of the VOC's, we typically tend to use SPC over TPC.

4.3.4 Catalyst Particle Selection and Packing in a Reactor

A catalyst bed can consist of various types of packing's. Depending on the size of the ferroelectric particles that we choose and the type and shape of the catalyst particles, the packing of the catalyst in the reactor would determine [31]. An example of various types of packing can be seen in the figure 26(a).

The first reactor in figure 26(b) is a general packed bed plasma reactor where only the ferroelectric particles are packed in the reactor. Usually these are taken as a reference reactor when scaling up to a big reactor.

In Figure 26(c), the catalyst particles are smaller in diameter than that of the ferroelectric particles. This is another type of reactor setup and it has its own advantages as these particles can fit into the gaps where the ferroelectric particles are tightly packed. This increases the effective

surface area of the catalyst exposed to the plasma and the treatment of the VOC.

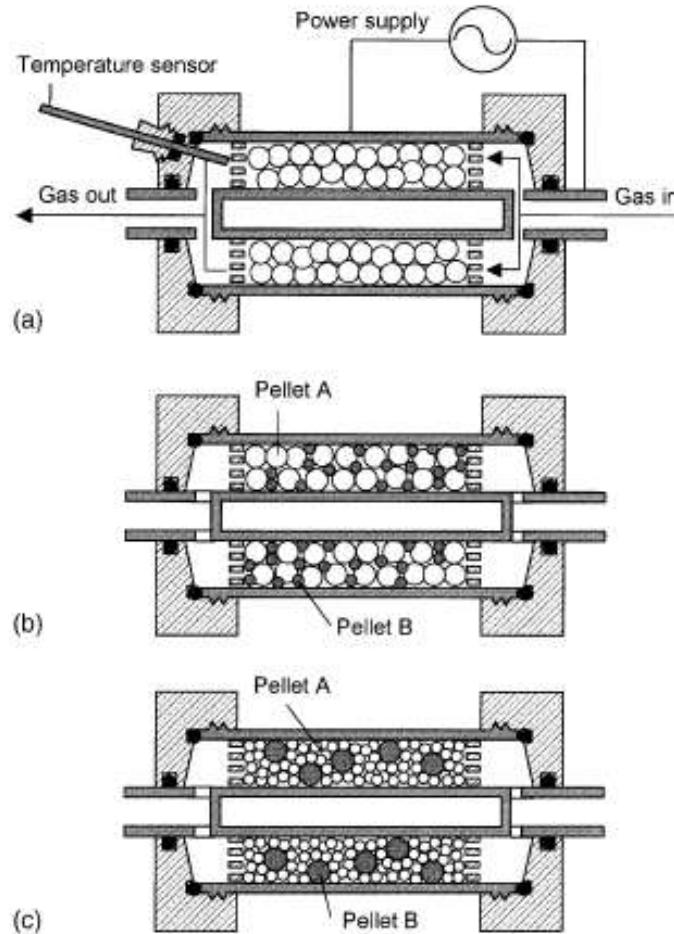

Figure 26. Different types of packing of catalyst (a)only BaTiO_3 , (b) BaTiO_3 +Catalyst Al_2O_3 (c) BaTiO_3 + Catalyst Al_2O_3 (Alumina big) [31]

In Figure 26 (c), the catalyst particles are bigger than the ferroelectric particles. In this case, the plasma is formed over the particles and this is mostly catalyst dominated bed as most of the treatment of the VOC's is done majorly by the catalyst.

All these different configurations are helpful in the destruction of the VOC's for different types of processes involving different types of interactions with the catalyst type and the ferroelectric particles with the effluents containing VOC's. For bigger catalyst particles, the formation of plasma will be less, i.e., the effective plasma reactive area will be less and the effects would be more. This is more useful when the reactant gas is more reactive and when it interacts with plasma and when it forms a lot of free radicals, then the catalyst surface can come into the

picture as the free radical interaction with the catalyst is helpful for the reduction of the VOC systems.

4.3.5 Plasma Formation When Catalyst Is Used

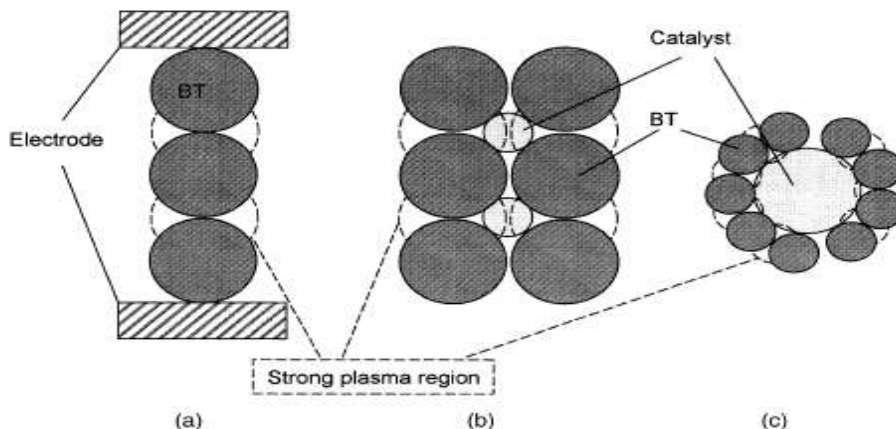

Figure 27 (a) Only ferroelectric materials, (b) Catalyst articles<Ferroelectric particles, (c) Catalyst particles>Ferroelectric particles [32]

In figure 27, we can see that the areas where the plasma is formed when the particles are closely packed [32]. The dotted line indicates the region where the plasma is formed. Hence when a gas is passed through the packed bed, it is passed through these regions and hence the effluent gases are treated. In case (b), the catalyst particles are located in between the packed ferroelectric particles. Hence the catalyst activation is also possible in this type of setup and the VOC's can also get adsorbed or react with the catalyst and hence get treated. This is advantageous in various ways as the effluents that are not treated by the plasma can be treated by the catalyst. Hence, an improved efficiency can be obtained. In case (c), the catalyst particles are bigger than the ferroelectric particles. Hence, the treatment is majorly by the catalyst than the particles. It is not preferred as the plasma region increases the generation of the radicals which then, when treated with the catalyst, improves the performance. Its efficiency might be similar to the previous configuration but it's not effective in treating all the effluents. A typical effluent (benzene) has been studied for the selection of particle sizes in a reactor.

4.3.6 Effect of Particle Size in the Packed Bed Reactor

The figure 28 shows a trend of the decomposition of benzene when using various particle sizes. The specific energy density is considered while checking for the efficiency of the reactor. Specific energy density is the energy output generated per liter of the gas that flowed through the reactor. The conversion of the benzene was plotted against specific energy density for various particle sizes. From the graph we can see that the particle sizes of

1mm and 2 mm are more efficient in conversion than those of 3 mm particles. Hence, the particle size should be less than 3 mm. Also, the particle size depends on the size of the catalyst particle selected. Hence, the understanding of the particle size on the conversion must be known before considering the design.

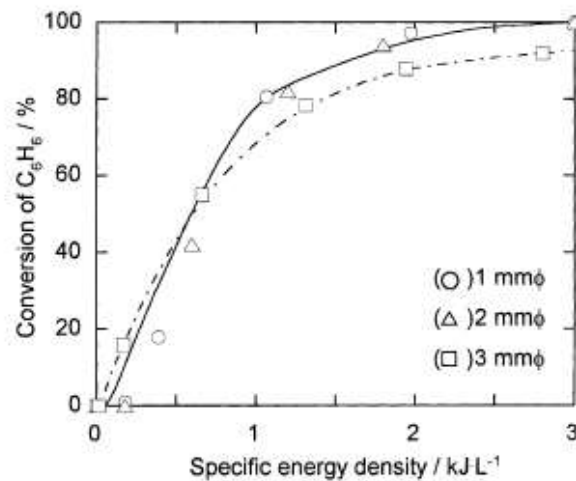

Figure 28 Graph showing conversion Vs Specific Energy Density [6, 24]

4.3.7 Effect of Mixing of Particles IN PBD

The particles can show higher conversions when mixed with various particles [24]. Various combinations have been checked for the performance enhancement in a packed bed reactor. From figure 29, we can see the various combinations of the particles sizes and materials that have been used. The best performance was seen for the particles of 75-25 combination of barium titanate and calcium titanate and 80-20 Barium titanate and alumina. Here, calcium titanate can act as ferroelectric particles and as an adsorbent for the effluent gas. When using alumina, it can also act as a catalyst, hence increasing the performance of the decomposition.

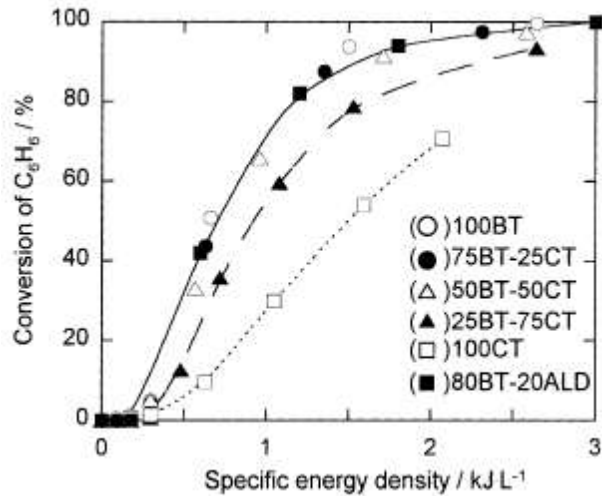

Figure 29 Conversion Vs SED [24]

4.3.8 Reduction of Effluents

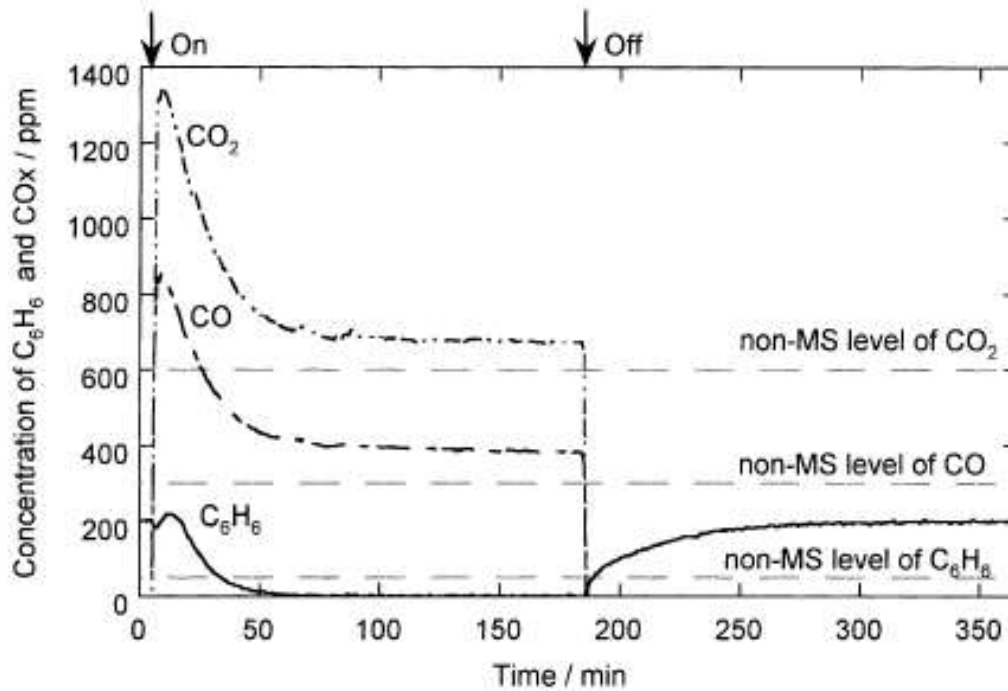

Figure 30. Conc. Levels of Benzene and COx over time in the reactor [29]

In the figure 30, we can see the destruction of benzene and COx over time in the reactor. The concentration levels of the effluents are measured from the start of the plasma formation. We can see that the levels of the effluents are high initially and decrease as time goes on. In about 180

minutes, the complete destruction of the effluents is seen. The effluents are completely destroyed into their respective elemental states and based on the conditions, the further reaction to form synthesis gas is promoted. Synthesis gas is a source of fuel for H₂ gas which is the major energy fuel.

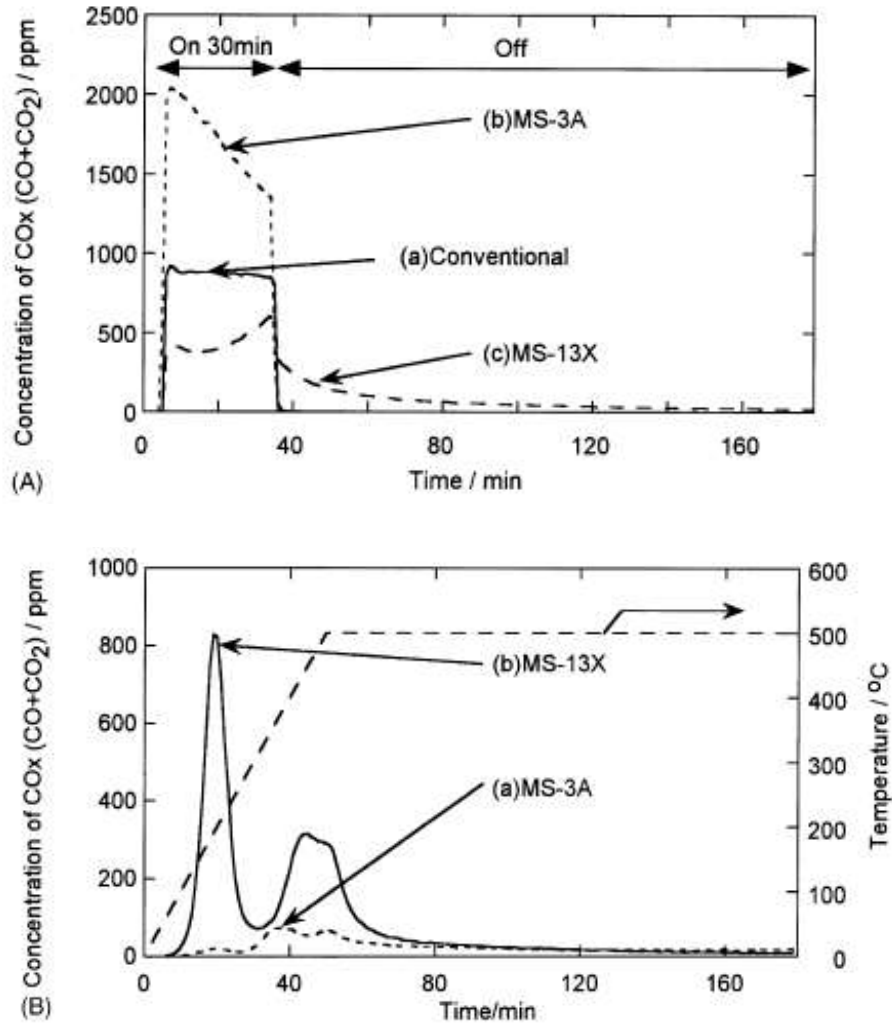

Figure 31. Levels of COx with plasma and with plasma + catalyst [29]

In figure 31, the concentration levels of CO and CO₂ over time in the reactor is shown. The levels of the effluents reduce drastically after 30 minutes. The comparison is made for the typical conversions over different reactors and their concentration levels. We can see that the MS-3A, whose particle size of the ferroelectric particles is more than that of the catalyst particles, has the highest reduction levels and the conversion in the same amount of time. Hence, the effect of particle size in the conversion is also important for the effluent removal. A general overview of

various catalysts and how they are combined with the plasma is listed in the table 3. It also shows the removal efficiency improvement in SPC of compared to plasma alone.

Table 3. Showing Various Catalysts Used for Various VOC's And Their Introduction in the System [33]

POLLUTANT	Conc (PPM)	Plasma Reactor	CATALYST	HOW THE CATALYST IS COMBINED WITH PLASMA	Plasma-Alone			SPC		
					Removal Efficiency	CO ₂ Selectivity	Carbon Balance	Removal Efficiency	CO ₂ Selectivity	Carbon Balance
Benzene	105	DBD	TiO ₂	Catalyst is deposited on the inner surface of dielectric layer	33	-	93	61	-	83
	200	Surface Discharge	1% Ag/TiO ₂	Catalyst pellets are packed inside the surface discharge reactor	53	55	100	89	72	100
	1500	Corona	TiO ₂	Catalyst is deposited on glass wool, which is used as packing material	81	54	62	91	58	68
	100	DBD	1.5% TiO ₂ /γ-	Catalyst pellets are mixed with	30	20	-	48	24	-

			Al ₂ O ₃	non-catalytic glass beads						
Ethylene	30,000	Corona discharge	TiO ₂	Catalyst is deposited on glass wool, which is used as packing material	47	29	99	67	36	94
Formaldehyde	276	DBD	7% Ag/CeO ₂	Catalyst pellets are packed inside the DBD reactor	57	6	-	99	87	-
TCE	1000	DBD	TiO ₂	Catalyst pellets are packed inside the DBD reactor	85	-	-	98	-	-
Toluene	100	DBD	3% MnO _x ^b	Catalyst is deposited on surface of inner electrode	66	23	63	78	56	77

Chapter 5

Final Reactor Design

In the literature review a thorough study of all the reactors were made. It has been discussed that out of all the reactors, the Plasma Driven Catalysis reactors are the most effective, as they produce negligible amount of aerosols compared to other reactors. Also PDC reactors are the most energy efficient reactors and its Carbon dioxide selectivity is the highest. But since its dynamics has not been properly understood till date, designing it and scaling it up might pose a problem. Instead the PEC reactors whose performance is comparable to the performance of the PDC reactors has been studied and has been designed and scaled up to serve small scale industries. So the basis of the design that is considered here is a PDC reactor that has been used in the industry to treat VOC. The plan of this project is to consider this as the basis of the design and then modify it to make it more compact, energy efficient and enhance the treatment capacity.

5.1 Design modification

To improve the treatment rate and also make it more compact in size, it is packed with BaTiO₃ ferromagnetic materials and Alumina catalyst [35]. The ferromagnetic materials act strongly to the electromagnetic field generated. Its molecules get arranged orients themselves in such a way that plasma formed is more homogenous and concentrated. Thus the system is designed in such a way that:

1. Using the catalyst complete conversion of the VOC to carbon dioxide and carbon monoxide without formation of other hydrocarbons is possible
2. If the oxygen concentration in air can be increased above 5% selectivity of Carbondioxide over Carbon monoxide is greatly improved.

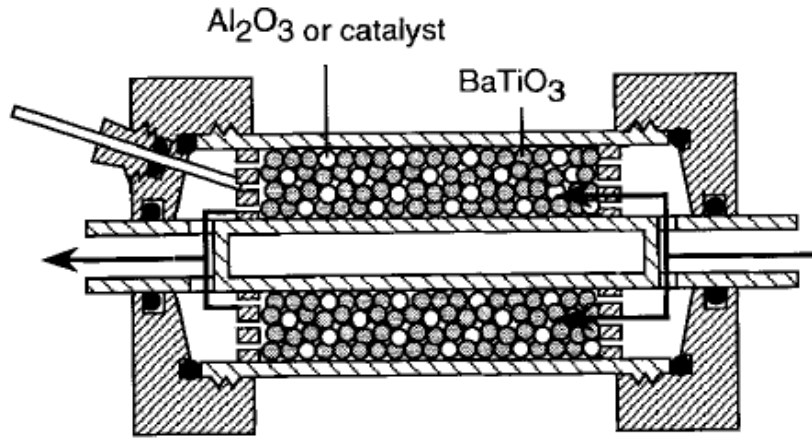

Figure 32. Catalytic reactor [35]

5.2 Scale-up Calculations

For scaling up following assumptions are made:

- The porosity (ϵ) was calculated to be 0.733 assuming there are 5 particles in a cross section of 10mmX 2mm section of the experimental setup. We assume the scaled reactor is also having the same porosity.
- The density (ρ) of the inlet gas was assumed to be 1.251 g/L (Same as that of air).
- The viscosity (μ) of the inlet gas was assumed to be $.01781 \times 10^{-2}$ g/(cc.sec).
- The flow in the lab scale reactor was laminar flow which is assumed to be the same in the modeled reactor.
- All the particles are assumed to be perfect spheres. Hence sphericity (ϕ_s) is 1.
- The target gas flow rate is 2000 L/min.

First the calculations for the experimental set-up are made:

$$\text{Volume of the reactor (V)} = \left(\frac{\pi}{4}\right) * (L) * (d_o^2 - d_i^2) \quad (5.1)$$

$$= 31415.926 \text{ mm}^3$$

$$= 31.415 \text{ cm}^3$$

$$\text{Porosity } (\epsilon) = 1 - \{(\text{vol. fraction of spheres})\} \quad (5.2)$$

$$= 1 - \left\{ \frac{(n * 4 * \pi * (0.2)^3)}{(3 * 31.415)} \right\}$$

$$=.733$$

$$\begin{aligned} \text{Reynolds Number} = \text{Rep} &= \{(\rho * V_s * D_p * \phi_s^2) / [\mu * (1 - \epsilon)]\} & (5.3) \\ &= \{[1.251 * (.2/60) * (1/25.1327) * .2 * 1] / (.01781 * 10^{-2} * (1 - .733))\} \\ &= 0.6978 \\ &= \text{Laminar flow} \end{aligned}$$

From Korenzy-Carmen Equation

$$\begin{aligned} \text{Superficial velocity} = \mu_o &= (\text{Volumetric flow rate}) / (\text{Effective cross-sectional area}) \\ &= (.2/60 * 25.1327) \text{ cm/sec} \end{aligned}$$

$$\begin{aligned} (\Delta P/L) &= \{[(150 * \mu * \mu_o * (1 - \epsilon)^2) / [D_p * \phi_s * \epsilon^3]]\} & (5.4) \\ &= \{[150 * .01781 * 10^{-2} * .2 * (1 - .733)^2] / [.2 * 60 * 25.1327 * .7333]\} \\ &= 1.602 * 10^{-2} \text{ g/s} \end{aligned}$$

$$\begin{aligned} \text{Reynolds Number} = \text{Rep} &= \{(\rho * V_s * D_p * \phi_s^2) / [\mu * (1 - \epsilon)]\} & (5.5) \\ &= \{(1.251 * 2000 * .2 * 1) / [60 * .01781 * 10^{-2} * [1 * r_e^2 * (1 - .733)]]\} \\ &= 55854.9 / r_e^2 \end{aligned}$$

- From Korenzy-Carmen Equation

$$\begin{aligned} (\Delta P/L) &= \{[(150 * \mu * \mu_o * (1 - \epsilon)^2) / [D_p * \phi_s * \epsilon^3]]\} & (5.6) \\ &= \{[150 * .01781 * 10^{-2} * 2000 * 10^3 * (1 - .733)^2] / [.2 * 100 * 60 * [1 * r_e^2 * .7332]]\} \\ (\Delta P/L) &= 256.675 / r_e^2 \end{aligned}$$

The pressure drop across the bed is assumed to be increasing as the same rate as that of the flow rate because of the increasing in the packing material in the reactor.

Hence,

$$\text{Re}^2 = 1.603 * L$$

From iterative calculations, the consideration for length is chosen to be 200 cm and the effective radius was

$$Re^2=320.24$$

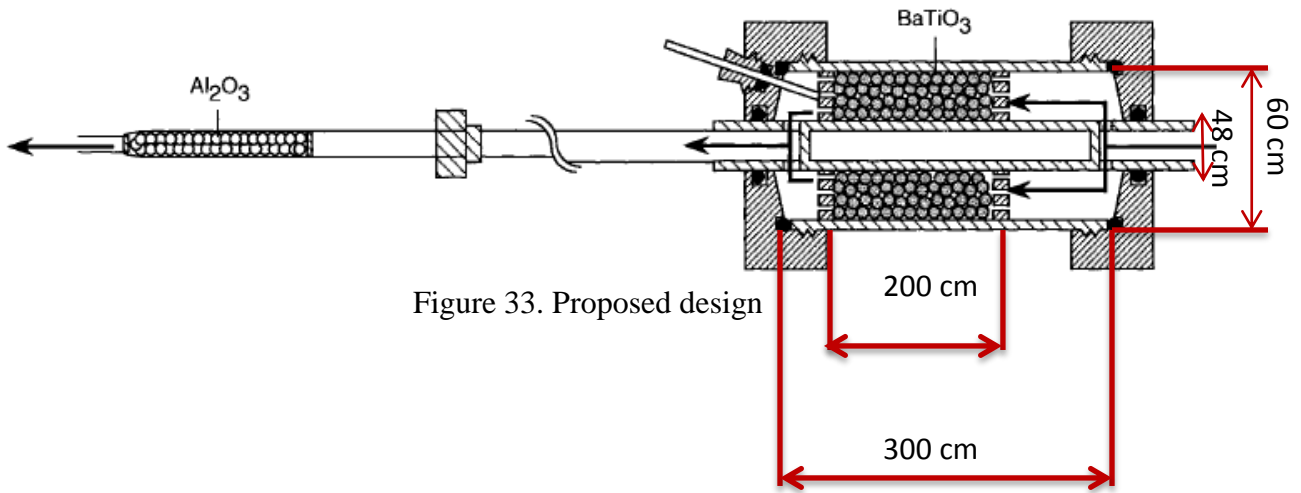

5.3 Plant lay-out:

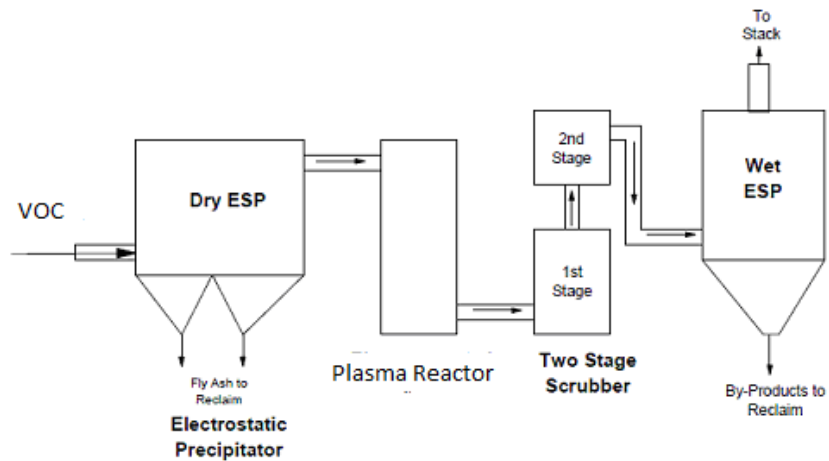

Figure 34. Effluent plant layout [source: epa/factsheets.gov]

The dry ESP should be used at the beginning to prevent any particulate matter from entering into the system which might otherwise create problems in plasma formation.

In the first and the second stage an ammonia scrubber and absorber unit is used which neutralizes the acid formed and absorbs it.

Finally the wet ESP will be used to remove mists and aerosols from the emissions.

5.4 Electrical system

The driving force for the plasma reactor is electricity. The schematic of electrical set up is shown.

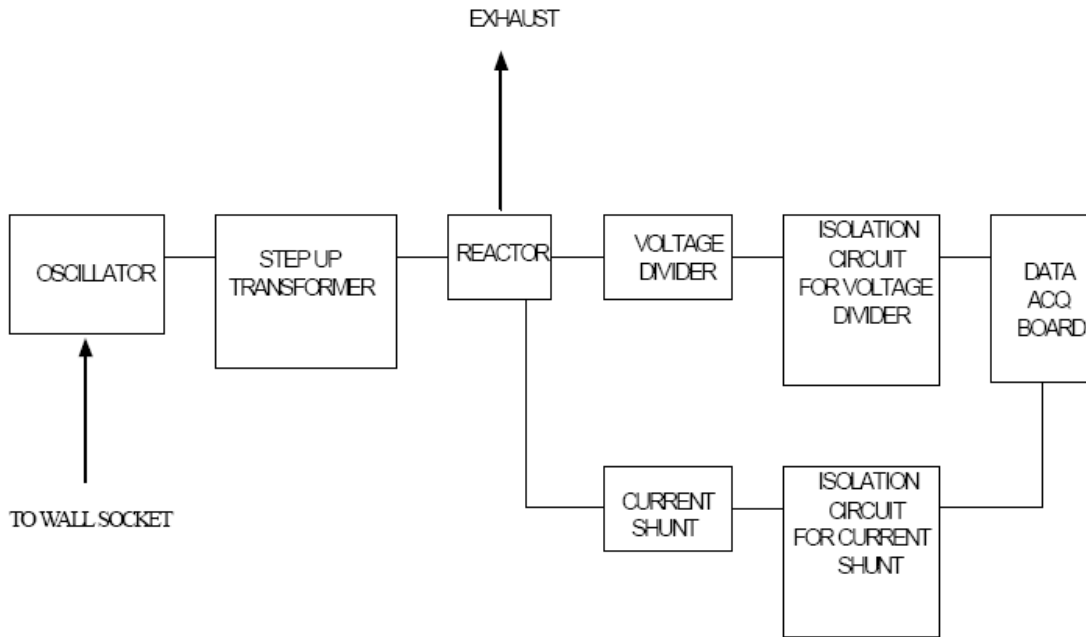

Figure 35. Electrical system of Plasma unit

The three basic systems in this electrical set up are the oscillator, the transformer, and the secondary voltage and current measuring circuit. The power from the wall socket is applied through a California Instruments Model 161 T oscillator. The oscillator range is from 40-5000 Hz, with a primary maximum of 120 Vrms.(Vrms = Root Mean Square Voltage)

This output voltage was stepped up to 15kV using a Franceformer model 15060P, 890VA center-tapped, luminous-tube transformer (Jefferson Electric). The electrodes of the plasma reactor were connected to the high-voltage; secondary terminals of this transformer by 8 mm multi thread silicone coated wires (Taylor Pro wire, Radio Shack Inc). When energized, this circuit created a plasma discharge within the reactor.

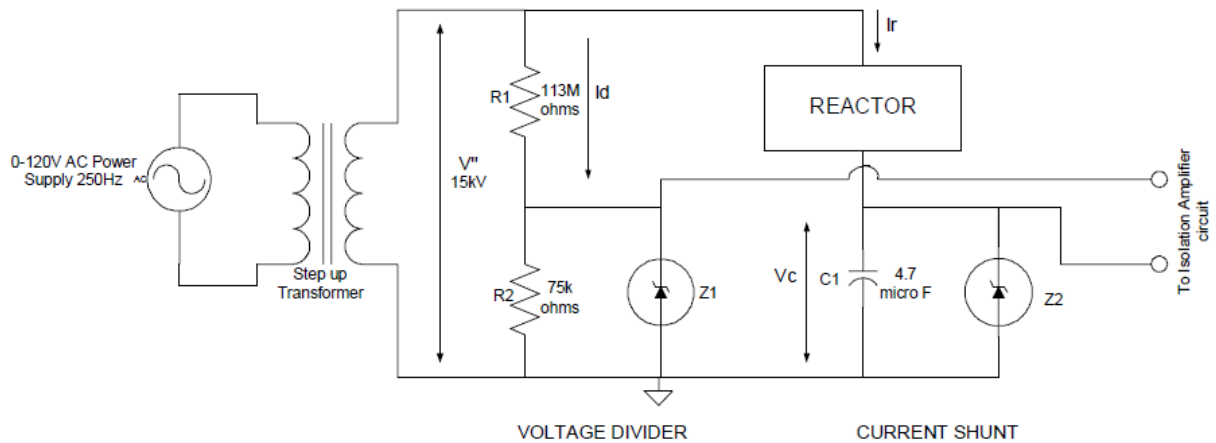

Figure 36. Voltage and Current Measuring Circuit

The maximum voltage drop across the reactor was 15kVrms. This voltage was too large to measure directly so a custom designed voltage divider was used to step the voltage down to a measurable value. The above figure shows the circuit used to measure the voltage across the reactor. The above figure shows the secondary power source for circuits used to measure the secondary voltage and secondary current [13, 11].

Voltage across the reactor and current through the reactor were monitored using a computerized data acquisition system. Each measured variable produces an electrical signal as output. Using Lab View software (National Instruments) these signals can be read and plotted. To monitor these signals, a data acquisition (DAQ) board was used. DAQ boards read both analog and digital signals. The DAQ board must be protected from the high voltages used to energize the plasma reactors because it can only withstand inputs in the range of $\pm 15V$. Isolation amplifiers were used to protect the DAQ board. An isolation amplifier acts as an interface between external devices and the data acquisition system (Veenstra, 2003). It provides galvanic isolation between the input and output. The outputs from all of the isolation amplifiers were connected to each channel of the DAQ board. Lab View software was used to program the DAQ board.

Chapter 6

Energy Economics & Analysis

6.1 Cost Effectiveness and Optimization

Cost effectiveness in terms of financial aspects and optimization in terms of systems design and plausibility of operation are two very important and critical aspects which have to be on the top of the priority list for any project. Before the start of any project things such as system design, feasibility of operation, related cost beneficiaries and overall plausibility of the project are a few things which engineers and personnel should seriously take into consideration [35]. It's always very advantageous to find the merits of any system but it is even more crucial to identify the negative aspects of the project because by doing so , the task for the overall planning and execution of the project becomes much more easier if not totally simple. Another thing which is also of utmost importance is the relative integration of different competencies and areas of the project so that it forms a very cohesive and homogeneous effort where the contribution of each of them is easily visible and properly stated.

The few important aspects which define our Non Thermal plasma system more efficiently are as follows

- The problem with determining the cost of a new control technology is the lack of public information.
- An NTP reactor will be a specialized custom made system
- Optimizing the performance of an NTP reactor is a complicated process
- Degree of removal of pollutant, decomposition products and energy consumption are critical evaluation parameters
- Preliminary economic analysis indicates that the major cost of an NTP reactor system resides in the cost of the electrical power supply
- In some cases the cost might be 75% of the plasma reactor cost
- The cost is expected to fall with the development of,
 - Better matched State-of-the-art power supplies
 - Operation of the plasma reactor at more optimal treatment conditions

The NTP technology has not yet been demonstrated at full-scale over a long-term period. For this reason, some uncertainty is associated with operation and maintenance costs. At the present stage of maturity, costs shown can be expected to fall in the +30% to 15% range. Cost projections are based upon lab and field tests and supplier recommendations [36]. Values provided for the NTP power supply and related equipment are based upon retail prices and do not take into consideration discounts that may apply for quantity. Finally, it is commonplace for thermal technologies (i.e., RTOs) to present unit costs in \$/1000 SCFM because it is economically favorable to do so for systems that treat small concentrations of contaminants in large volumes of air. However, as VOC emissions control takes the opposite approach, unit costs in \$/lb. of VOC destroyed may be a more appropriate way to judge NTP cost of ownership.

6.2 Figures of Merit

In any project, to define an entire process, parameters have to be stated which takes into account all the important variables which constitute the entire system. It is important to define each parameter depending on different process and equipment variables. These values help in monitoring of the performance and the operating efficiency of the entire system. Knowledge of these values allows scope for improvement in the running of the system in a more profitable and energy efficient way. Set points and values for parameter can be predefined and accordingly their changes can be carefully analyzed and recorded to improve the system in whatever possible it could be.

Given below are few of the most significant figures of merit which successfully define our Non Thermal Plasma system. These values would give us an insight to the critical parameters related to electrical energy, VOC removal and overall economics of the system.

- **Specific excitation power (P)**

- $P = 2fa\sigma E_{\mu}$

- Where f = frequency of the A.C. voltage supplied to the reactor, a = micro discharge area, σ = Number of micro discharge streamers per unit area, E_{μ} = Specific energy per micro discharge

- **Specific Energy (E)**

- $E = P T_r$

- Where P = Specific Power, V_r = Active volume of the reactor
- **Production efficiency (G)**
 - $G = f (K_{rad})/(v_d E/N)$
 - Where K_{rad} = effective rate constant for radical generation, v_d = electron drift velocity, E/N = reduced electrical field
- **Energy Density parameter of a given compound (β)**
 - $\beta = - E/\ln([X]/[X_0])$
 - Where E = Energy Density, $[X]_0$ = Initial Pollution concentration , $[X]$ = Final Pollution concentration
- **Average energy cost per removed molecule (γ)**
 - $\gamma = - \beta \ln ([X]/[X]_0)/[X]_0(1 - [X]/[X]_0)$
 - Where β = Energy density parameter, $[X]_0$ = initial concentration, $[X]$ = Final concentration

6.3 Detailed Cost estimate and analysis of the entire system

The total cost including capital and operational cost is calculated for the scaled up reactor, which has a flow rate of 2000 slm and 100 ppm of toluene. The cost of transformer, oscillator, blower and sensors are costs supplied by the respective vendors [39]. These costs include shipping and handling. Capital costs are segregated into equipment cost, electrical appliances cost, piping cost and the sensors and accessories cost. The calculations show that it would take \$0.075 to treat 2000 litre of air (100 ppm of toluene). A cost of ~ 9 cents per kilowatt-hour was assumed to calculate this operational cost. The detailed calculations are also explained at the end.

I. Capital Cost

Table 4. Capital cost

Unit	Quantity	Cost, \$	Vendor
Blower	1 (2000 L/min)	1480	Matches
Oscillator	1	795	Texas Instruments
Transformer	1 (1500 KVA)-GE PROLEC	14,000	Carrier Electric
Plasma Reactor			
Dielectric Quartz tubes	1 (61.5 cm *60 cm)	15,234	Technical Glass Products
Inner Electrode (stainless steel)	1 (48 cm*300 cm)	5,126	Small Parts Inc
Outer Electrode (copper foil)	1000 cm (bundle)	50	Sigma-Aldrich
Ferro electric packing material (barium titanate)	979 kg	29,370	Sigma-Aldrich
Fiberglass case for the reactor	1 (62 cm* 310 cm)	200	Niemiac Marine Inc
Alumina	244.8 kg	10,184	Sigma Aldrich

II. Capital cost for piping

Table 5. Capital cost for piping

Unit	Quantity	Cost, \$	Vendor
1. Carbon Steel			
16-10 inch RFSO 150-flange	1	744	Lamons Company Gasket
96-B7 Studs	1	192	
8-10 inch gaskets	1	168	
4-10 inch SK20 LR 90's	1	358	
40'-10' SK20 pipe	1	460	

III. Capital cost for electrical machineries and appliances

Table 6. Capital cost

Unit	Quantity	Cost, \$	Vendor
Voltage divider	1	8	Radioshack
Optical Isolators	1	15	Radioshack
Isolation Amplifiers	1	118	Radioshack
Breadboard wires	1	15	Radioshack
18AWG test lead wires	1	8	Radioshack
DAQ board PCI6023E	1	395	Radioshack
R6868 Ribbon cable	1	65	Radioshack
LAB view software	1	495	Techtronix

IV. Capital cost for sensors and spectrometers

Table 7. Capital cost for sensors and spectrometers

Unit	Quantity	Cost, \$	Vendor
Temperature	1	80	Omega
Pressure	1	85	MKS Instruments
Humidity	1	35	MKS Instruments
Power	1	150	Techtronix
Voltage	1	40	Techtronix
Spectrometer	1	1300	Stellar Net
Spectrometer	1	2400	Ocean Optics
GC-MS	1	9950	Thermo Scientific

6.4 Operating Cost

The operating cost calculation has been done considering the pertinent factors and is shown below

- Assume optimum energy density = 1500 J/L = 1500 watt-s/L
= 0.84 kw-hr/2000 slm
- Total Flow = 2000 slm = 120, 000 sl/hr
- Assume electricity cost = 0.09 \$/kw-hr
- Operational Cost = $(0.084 * 0.09) / 2000 \text{ slm} = \mathbf{0.075 \$/2000 \text{ slm}}$

6.5 Comparative study of NTP systems and conventional RTO systems

The two bar graphs which are shown below gives a representative & approximate comparative analysis of our proposed plasma device. It is clearly understood that the total annual cost of a NTP system is much less compared to other traditional thermal and catalytic oxidation systems. At this point it is worth mentioning that RTO systems can operate with higher flow rates of pollutants but in this regard also a plasma device has a distinct advantage [36]. Considering the size and total ergonomics of a unit plasma system, it will not at all be a difficult task to integrate a series of such devices to treat the maximum amount of pollutant streams and hence destruct the maximum percentage of VOCs. The following bar graphs have all been shown with similar flow rate treatment amounts. All these prove that our system has a lot of advantages in comparison with other techniques.

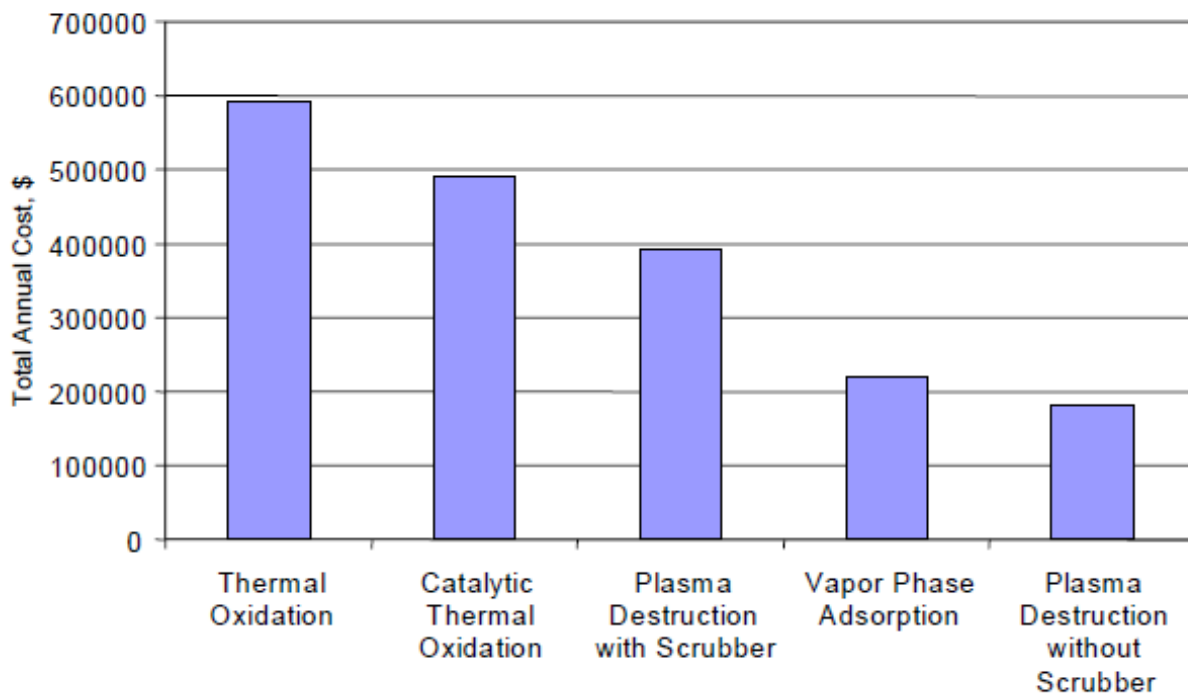

Figure 37. Total Annual Cost Comparison of Control Techniques

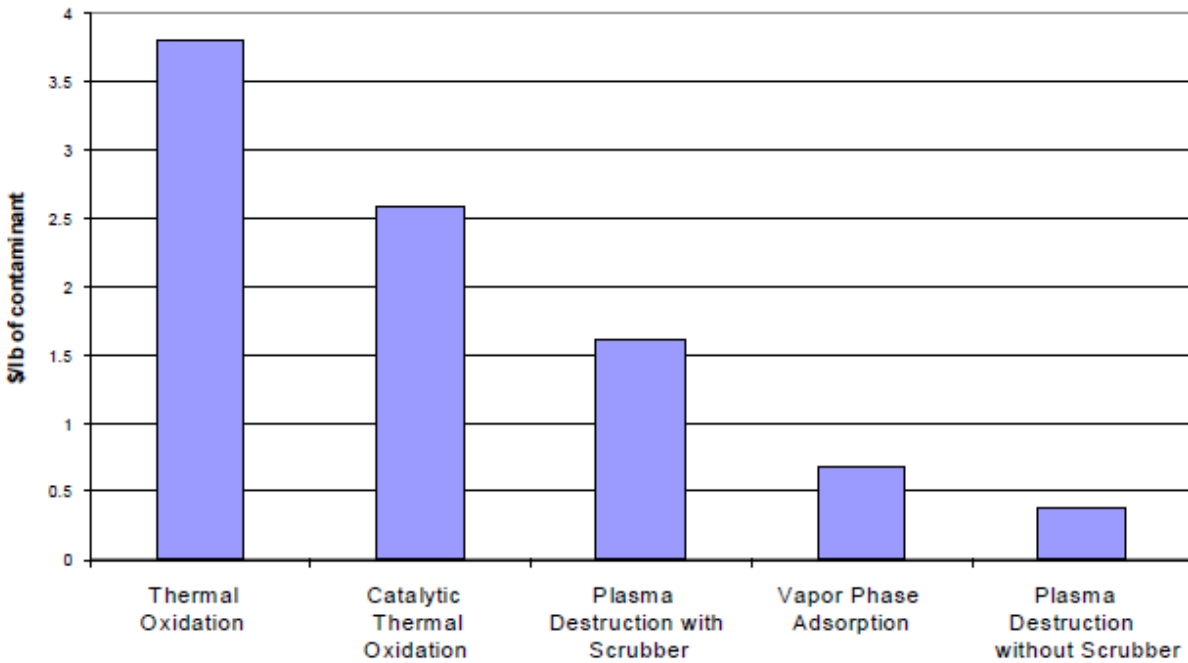

Figure 38. Removal Cost per Unit Contaminant at 2000 L/min and 2000 ppm

6.6 Sensitivity Analysis

Non thermal plasma systems show optimal performance under a high concentration, low flow regime. It is not particularly sensitive to influent exhaust stream concentration, but is sensitive to flow rate, specific exhaust compound(s), and the target DRE. Cost of ownership calculations depend upon these latter three parameters [37]. These results show both advantages and disadvantages to the system. If the target compounds are favorable to destruction via NTP such as those emitted by paint exhaust (ie., Toluene, Benzene), and if flow rates are relatively low (i.e., ranging from approximately 100-500 slm), then the cost of ownership is competitive. If, on the other hand, target compounds are unfavorable to NTP treatment such as those emitted by solvent benches (ie., acetone), then cost of ownership becomes relatively high, particularly at the high flow rates (3000-4000 slm) associated with solvent bench exhaust output. Cost is also dependent on the specific target DRE (Destruction Removal Efficiency). Increasing DRE from 90% to 99.9% or greater is achievable, but operating costs increase accordingly.

The most expensive capital component for an NTP system is the power supply -- approximately \$1.00 per watt for power supplies ranging in design from 15 - 100 kW. The cells and support

equipment are made from simple, inexpensive materials and are minor components of capital cost. Total annual costs and unit costs are dependent upon values given for the important parameters of flow rate, energy density requirement for a particular compound, desired DRE, and exhaust stream duty cycle. Because of the dynamic influence of these parameters on cost, a sensitivity analysis is presented showing their relationship to the cost of ownership.

The main salient features of the sensitivity analysis are listed below:

- A technique used to determine how different values of an independent variable will impact a particular dependent variable under a given set of assumptions
- This technique is used within specific boundaries that will depend on one or more input variables
- The four major parameters that influence the NTP reactor cost of ownership are
 - Flow Rate
 - Energy density (power requirement)
 - Target effluent concentration (DRE)
 - Duty Cycle (Percentage of time that exhaust output is actually being emitted)
 - The cells and support equipment are made from simple inexpensive materials and are minor components of capital cost
- Total annual costs and unit costs are dependent upon values given for the important 4 parameters
- Due to the dynamic influence of these parameters on the cost, a sensitivity analysis is essential showing their relationship to the cost of ownership

6.6.1 Sensitivity Analysis Process Curves

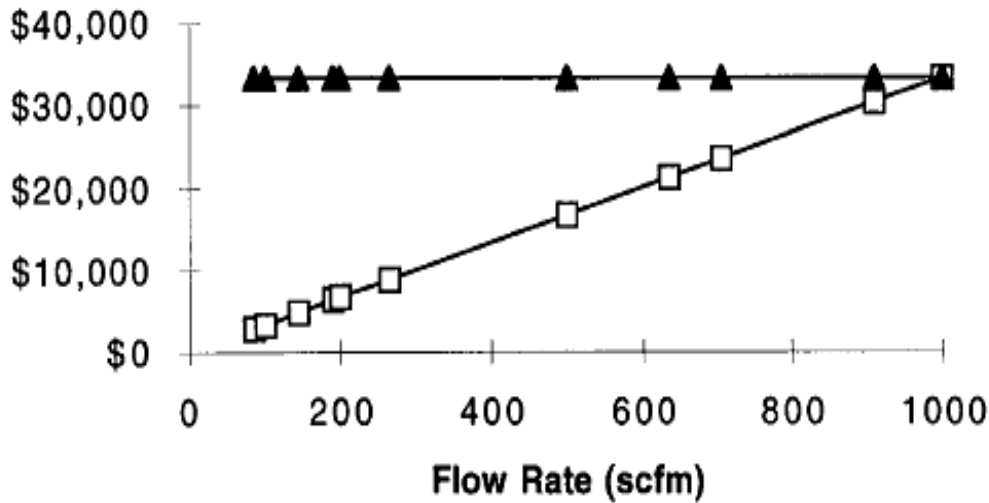

Figure 39. It illustrates the relationship between cost and flow rate. As shown, the total annual cost rises with the increase in flow rate; however, the unit cost stays constant due to the linear dependence of cost on flow rate [38].

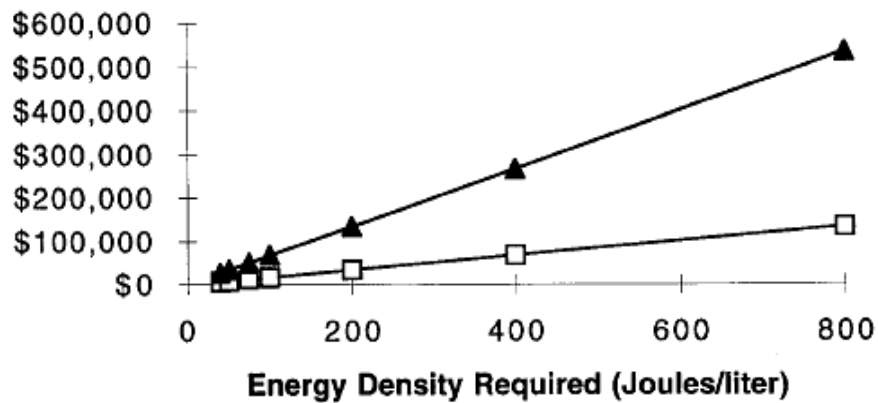

Figure 40. The above figure illustrates the relationship between cost and energy density requirement. The energy density required is empirically derived from the specific compound(s) of interest in the exhaust stream. The energy density is a function of power, so an increase in the

energy requirement means a necessary increase in the power supply at a fixed flow rate, and hence, a concomitant increase in capital and utilities costs. Looking at the slope of the two cost curves, it is evident that unit cost is particularly dependent on the compound of interest [38].

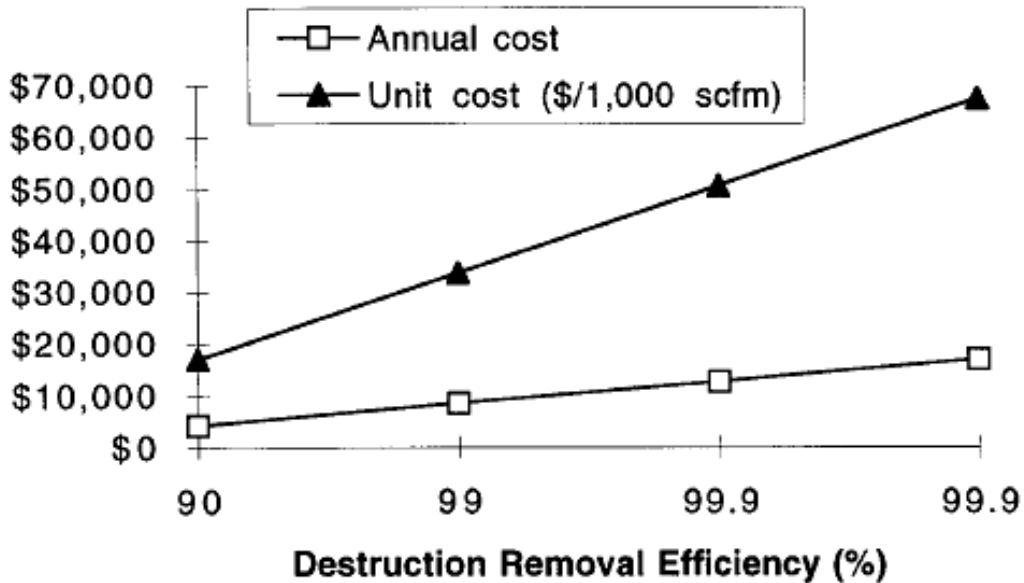

Figure 41. The above figure shows how the cost increases as a function of destruction removal efficiency. Each "nine" increases the power required to maintain the the energy density for greater percentage destruction of a given compound. We can observe that the unit cost doubles from \$16,700 to \$33,300 per 1,000 lpm when the target DFE is increased from 90% to 99% [38].

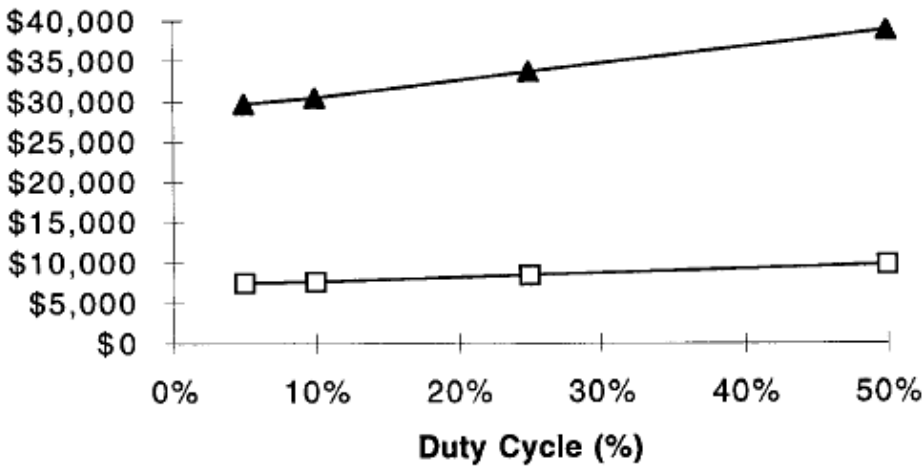

Figure 42. The above figure shows that cost increases with an increase in duty cycle, but it is evident from the shallow slope of the cost curves that neither annual nor unit cost is as strongly affected by changes in the duty cycle as with the other parameters above. This is because duty cycle does not affect the design specs for the power supply, so capital cost is independent of the duty cycle. The change in cost as duty cycle increases reflects an increase in electrical utility cost requirements [38].

6.6.2 Representative Voltage plots & explanations related to the NTP System

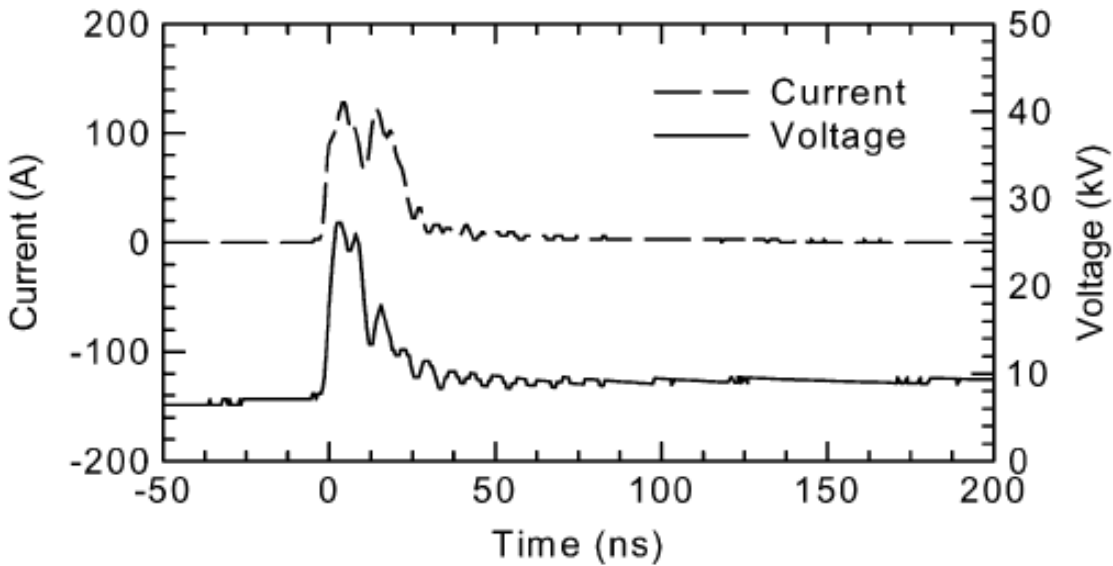

Figure 43. Deposited power in the NTP system is measured using a capacitive voltage probe and a current-viewing resistor. Representative current and voltage waveforms are shown in the above

figure. The deposited energy per pulse is given by integrating the product of the current and voltage over the pulse duration. The average specific energy is obtained by summing the energy in the number of individual pulses (n) occurring during the residence time of the processed gas flowing through the reactor and dividing by the reactor active volume (Δv) : $E = nE_p / \Delta v$ [39]

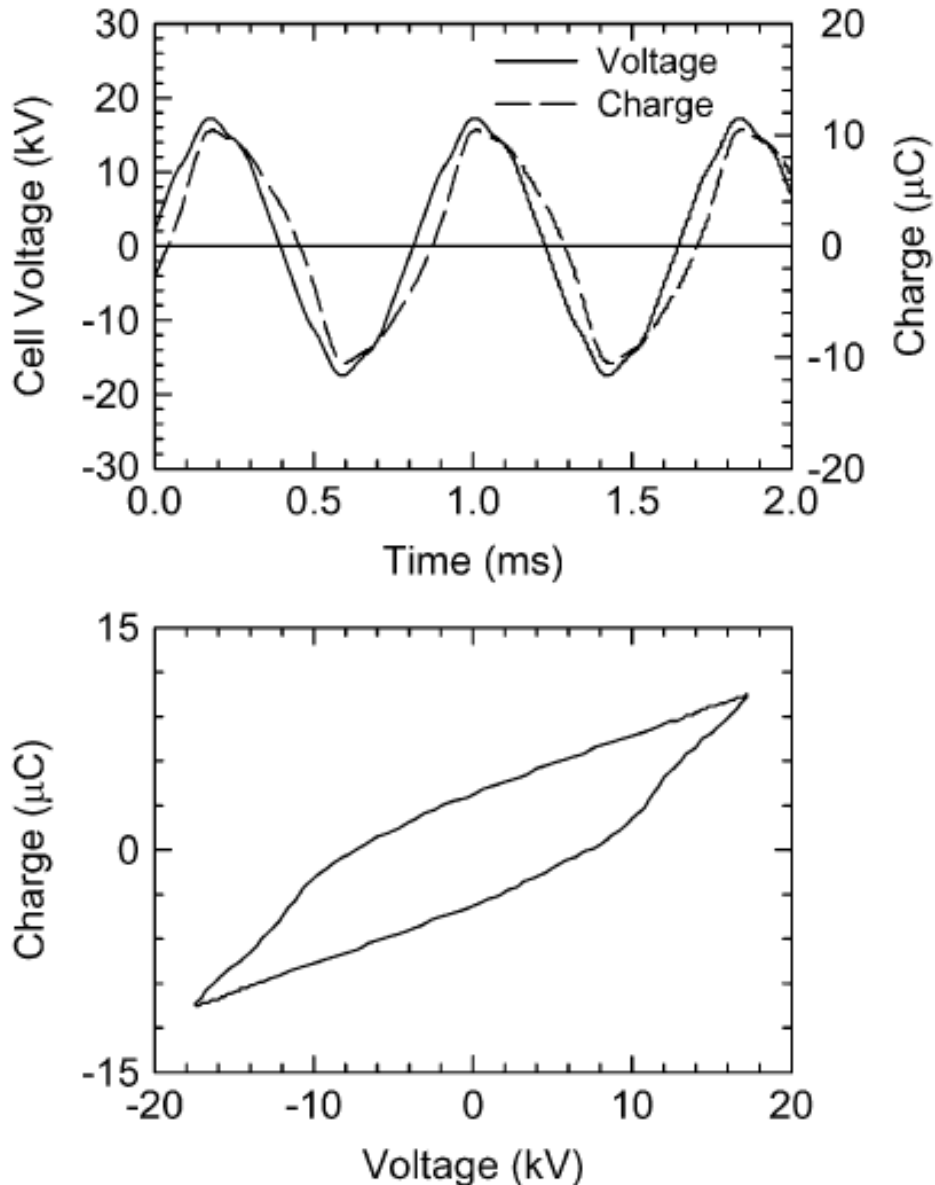

Figure 44. Deposited power for the DBD reactor is measured with a voltage probe and charge-measuring capacitor. Example waveforms for a typical DBD reactor are shown in the above figure. The voltage and current are out of phase because the plasma reactor load has a reactive,

as well as resistive component. The applied cell voltage must exceed the breakdown voltage of the gas gap in the reactor. The reactor power is given by the area of the charge-voltage plot multiplied by the ac frequency of the applied voltage. The energy density is computed using the relationship E (reactor power P divided by the gas flow rate Q) [40].

Chapter 7

Conclusion

After careful analysis of background knowledge about plasma, study of different plasma parameters and proven pros and cons of non-thermal plasma reactor systems, we come to a conclusion that cost effective and energy efficient system could be developed which could be an alternative to thermal incinerator system. The main scope for deciding on a final design will be carried out now considering all the factors. There are some prevalent advantages and disadvantages associated to each system. So we are trying to plan our design in such a way to make it a kind of exclusive VOC removal system based on flow rates handled and nature of VOC to be destroyed. Different kinds of catalyst have also to be incorporated into the NTPR system to compliment the performance characteristics. Ferroelectric materials help in the entire system by improving the effective surface area for stable plasma sustenance. Basically it's a tradeoff between different plasma configurations, variety of industrial scale catalysts, novel reactor process conditions and inexpensive powering equipments to make it a lucrative system for VOC abatement. Different case studies will be taken into consideration for comparison of conventional incinerators and plasma based system in order to confirm on its improved performance.

- Low-T plasmas can be used effectively for the treatment of gaseous waste streams containing VOCs in a bench-scale R&D environment
- It appears that non-thermal plasma technology works to reduce certain pollutants from emissions. However the technology is still in the early developmental stage. The control cost and control efficiencies need to be documented and published by an independent third party.
- Capital and operating costs for a turn-key installation are probably not available and can only be determined by the installation and operation of a pilot plant at the individual facility.

7.1 Low-T plasmas for Environmental Applications:

- High Percentage of VOC Destruction in Low-Flow Applications
- Reasonable Destruction Efficiency in High-Flow Applications
- Extensive Characterization of By-Products

- High Level of Carbon Closure

7.2 Challenges Remaining

- Scale-up to high gas flow is non-trivial
- Cost and energy efficiency (vs. competing technologies)
- Materials for long-term, maintenance-free operation
- Control of by-product formation
- Poorly understood plasma chemistry
- Coupling of discharge physics to plasma chemistry

Large-scale industrial utilization is still some time away !

Chapter 8

References

- [1] B M Penetrantey, M C Hsiaoy, J N Bardsleyy, B T Merritty, G E Vogtliny, A Kuthiz, C P Burkhartz and J R Baylessz *Plasma Sources Sci. Technol.* **6** (1997) 251–259
- [2] A. Koutsospyros, S.-M. Yin, C. Christodoulatos, K. Becker *International Journal of Mass Spectrometry* 233 (2004) 305–315
- [3] B. M. Penetrante, R. M. Brusasco, B. T. Merritt and G. E. Vogtlin *Pure Appl. Chem.*, Vol. 71, No. 10, pp. 1829±1835, 1999
- [4] <http://www.epa.gov/iaq/voc.html>
- [5] EPA, 1996a. U.S. EPA, Office of Air Quality Planning and Standards, “OAQPS Control Cost Manual,”
- [6] <http://www.anguil.com/resources/overview-of-emission-control-technologies.aspx>
- [7] David Alexander Staack, Doctor of Philosphy ,”Characterization and Stabilization of Atmospheric Pressure DC Microplasmas and their Application to Thin Film Deposition”
- [8] B M Penetrantey, M C Hsiaoy, J N Bardsleyy, B T Merritty, G E Vogtliny, A Kuthiz, C P Burkhartz and J R Baylessz *Plasma Sources Sci. Technol.* **6** (1997) 251–259
- [9] Hyun-Ha Kim *Plasma Process. Polym.* 2004, 1, 91–110
- [10] A. Koutsospyros, S.-M. Yin, C. Christodoulatos, K. Becker *International Journal of Mass Spectrometry* 233 (2004) 305–315
- [11] R. G. Tonkyn, S. E. Barlow, T. M. Orlando *J. Appl. Phys.* 80 (9), 1 November 1996
- [12] Zh. Bo, J. H. Yan, X. D. Li, Y. Chi, K. F. Cen, B. G. Che´ron *Plasma Chem Plasma Process* (2007) 27:546–558

- [13] Hyun-Ha Kim, Seung-Min Oh, Atsushi Ogata, Shigeru Futamura *Applied Catalysis B: Environmental* 56 (2005) 213–220
- [14] Hui-Xian Ding, Ai-Min Zhu, Fu-Gong Lu, Yong Xu, Jing Zhang, Xue-Feng Yang *J. Phys. D: Appl. Phys.* 39 (2006) 3603–3608
- [15] B. M. Penetrante, R. M. Brusasco, B. T. Merritt and G. E. Vogtlin *Pure Appl. Chem.*, Vol. 71, No. 10, pp. 1829–1835, 1999
- [16] H H Kim, K Takashima, S Katsura and A Mizuno *J. Phys. D: Appl. Phys.* 34 (2001) 604–613
- [17] Jim Van Durme, Jo Dewulf, Christophe Leys, Herman Van Langenhove *Applied Catalysis B: Environmental* 78 (2008) 324–333
- [18] Hyun-Ha Kim, Seung-Min Oh, Atsushi Ogata, Shigeru Futamura *Catalysis Letters* Vol. 96, Nos. 3–4, July 2004 (2004)
- [19] Alice M. Harling, David J. Glover, J. Christopher Whitehead, Kuizhang *Environ. Sci. Technol.* 2008, 42, 4546–4550
- [20] Duan Li, Daisuke Yakushiji, Seiji Kanazawa, Toshikazu Ohkubo, Yukiharu Nomoto 0-7803-7116-X/01/\$10.00 (C) 2001 IEEE
- [21] R. G. Tonkyn, S. E. Barlow, T. M. Orlando *J. Appl. Phys.* 80 (9), 1 November 1996
- [22] Atsushi Ogata, Daisuke Ito, Koichi Mizuno, Satoshi Kushiyama, Arkadi Gal, Toshiaki Yamamoto *Applied Catalysis A: General* 236 (2002) 9–15
- [23] *Applied Catalysis A: General* 236 (2002) 9–15 *J. Appl. Phys.*, Vol. 85, No. 1, 1 January 1999

- [24] Monica Magureanu, Nicolae B. Mandache, Pierre Eloy, Eric M. Gaigneaux, Vasile I. Parvulescu *Applied Catalysis B: Environmental* 61 (2005) 12–20
- [25] H. Huang, L. Tang 2006 *Published by Elsevier Ltd.*
- [26] R. G. Tonkyn, S. E. Barlow, and T. M. Orlando *J. Appl. Phys.* **80** (9), 1 November 1996
- [27] Hyun-Ha Kim, Seung-Min Oh, Atsushi Ogata, Shigeru Futamura *Catalysis Letters Vol. 96*, Nos. 3–4, July 2004 (2004)
- [28] R. Rudolph, K.-P. Francke, H. Miessner 0272-4324 02 0900-0401 2002 *Plenum Publishing Corporation*
- [29] W. Mista, R. Kacprzyk *Catalysis Today* 137 (2008) 345–349
- [30] Ch. Subrahmanyam, M. Magureanu, A. Renken, L. Kiwi-Minsker *Applied Catalysis B: Environmental* 65 (2006) 150–156
- [31] K. Moustakas, D. Fatta, S. Malamis, K. Haralambous, M. Loizidou *Journal of Hazardous Materials B123* (2005) 120–126
- [32] Destruction of toluene in a dielectric discharge plasma reactor; Elangovan Karupasamy; Oklahoma State University; 2004
- [33] Destruction efficiency and power usage for a single dielectric discharge plasma reactor; Amanda Kathleen Benson; Oklahoma State University; 2005
- [34] Nonthermal plasma applications to the environment: Gaseous Electronics and power conditioning; Louis A. Rosocha; IEEE transactions; 2005

[35] Cost effectiveness of silent discharge plasma for point-of-use VOC emissions control in semiconductor fabrication; Mark Cummings and John Coogan; Institution of Chemical Engineers; 1997

[36] Air pollution control technology fact sheet; EPA-452; 2005

[37] Removal of Volatile Organic Compounds by atmospheric pressure dielectric barrier and pulsed corona electrical discharges; Louis Rosocha & Richard Kozekwa; Los Alamos National Laboratory; 2007

[38] Cost Analysis and economic assessment of proposed electric discharge non thermal plasma processes for NOX removal in jet engine exhaust; Louis A. Rosocha; Los Alamos National Laboratory; 1999

[39] David Alexander Staack, Doctor of Philosophy ,”Characterization and Stabilization of Atmospheric Pressure DC Microplasmas and their Application to Thin Film Deposition”

[40] B M Penetrantey, M C Hsiaoy, J N Bardsleyy, B T Merritty, G E Vogtliny, A Kuthiz, C P Burkhartz and J R Baylessz *Plasma Sources Sci. Technol.* **6** (1997) 251–259